



KRAL Screw Pumps – C Series.
Quality, innovation and short lead times.



■■■■■■■ Pumps

Our Legacy and Commitment.

Tapping into over 60 years of experience in ever improving quality and customer focus (think KRALity).

KRAL customer loyalty is the direct result of high KRAL quality. This stems from our know-how, in-depth expertise and the experience of our highly trained people.



- ▶ The company was founded in 1950. Even the very first pumps manufactured by the company were of the highest quality. Early KRAL domestic water pumps can still be found in operation today.
- ▶ In 2004 KRAL became the first pump manufacturer to offer hermetically sealed, magnetically coupled screw pumps suitable for industrial use at attractive prices.
- ▶ In 2012 KRAL doubled the capacity of its manufacturing plant in Lustenau, Austria.

We realize our vision of world-class quality through continuous improvement in our personnel, processes and product quality.

Customer satisfaction is generated through experience with our durable and reliable pumps together with an open partnership with our customers. We offer a wide array of standard pumps as well as custom solutions.

KRAL customers appreciate our commitment to on time delivery as well as fast response times for inquiries and requests.



KRAL AG operates in accordance with Total Quality Management principles.

The Screw Pump Advantage.

KRAL screw pumps deliver clear advantages.

KRAL screw pumps are self-priming displacement pumps. The specially designed profiles and tight tolerances of the three rotating screws form isolated and sealed chambers. Only through this operational principle can we ensure continuous and smooth pumping without damaging the liquid or creating turbulence.

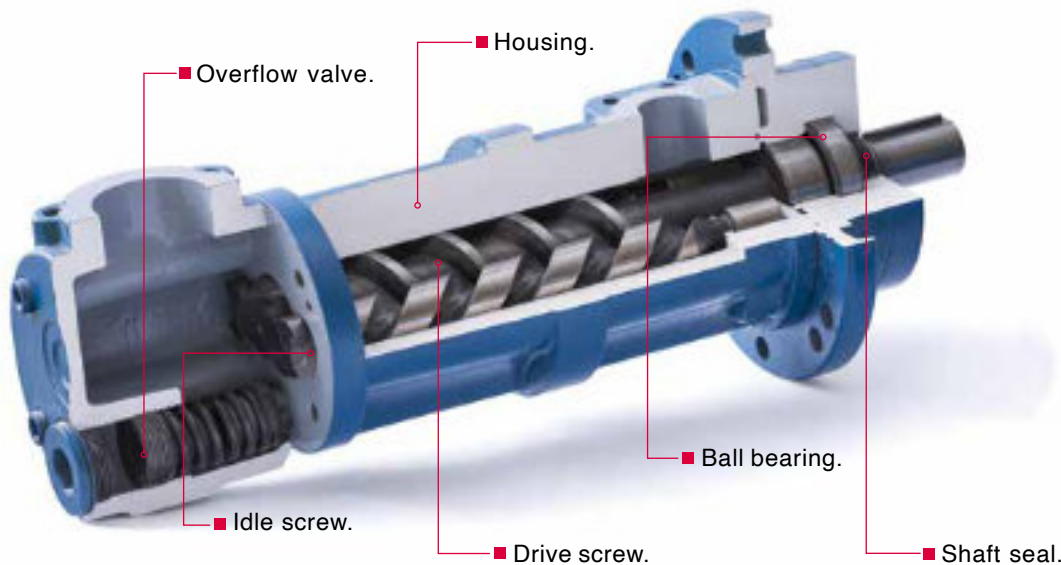

Clear advantages.

- Self priming.
- Quiet, no vibration.
- Low pulsation.
- Great suction lift.
- High efficiency.
- Compact.
- Long lasting.
- Simple construction.
- High speed capability.
- Directly driven.
- For low and high viscosity.
- Easy maintenance.

Operating Principle.

The screws are enclosed by the housing, forming tight clearances. The pumped liquid itself lubricates all the moving parts. Axial thrust acting on the hardened drive and idle screws is compensated by using precisely shaped balancing cylinders. A sliding bearing made of special materials absorbs axial and radial forces on the idle screws. The sealing chamber housing for the shaft seal has only suction pressure applied to it. Just the right flush volume flows from the pressure side to the sealing chamber and serves to cool and lubricate the seal.

The standard cast pump housing has SAE ports on the

top for suction and discharge. Optionally, the pump can be supplied with ANSI or DIN flange adapters. An axial inlet arrangement (end suction) is also possible as well as rotating the inlet port. Accessories such as an inlet strainer, suction piping and suction housing with or without a relief valve can be customized for the specific application. The pumps can be equipped with an electric or steam/fluid heating system. On CG pumps with fabricated steel housings, the inlet and outlet flange location, type, rating and size can all be freely specified.

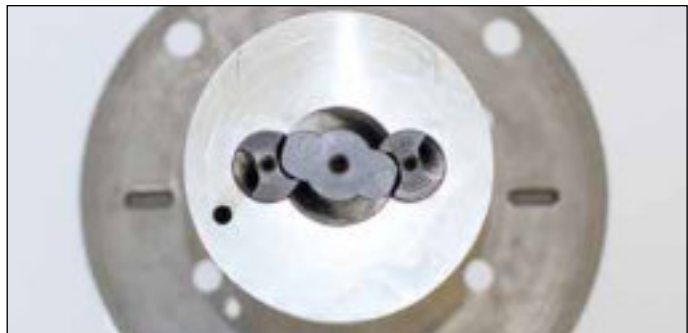

Screw pumps have a constant, free cross-sectional area that ensures continuous displacement of the pumped liquid.

■■■■■■■■ Pumps



Reliability and Durability by Design.

Operating principle of a screw pump.

High flow rates and pressures with a very compact footprint, low pulsation and great control capabilities – these are the clear technical advantages of a screw pump.

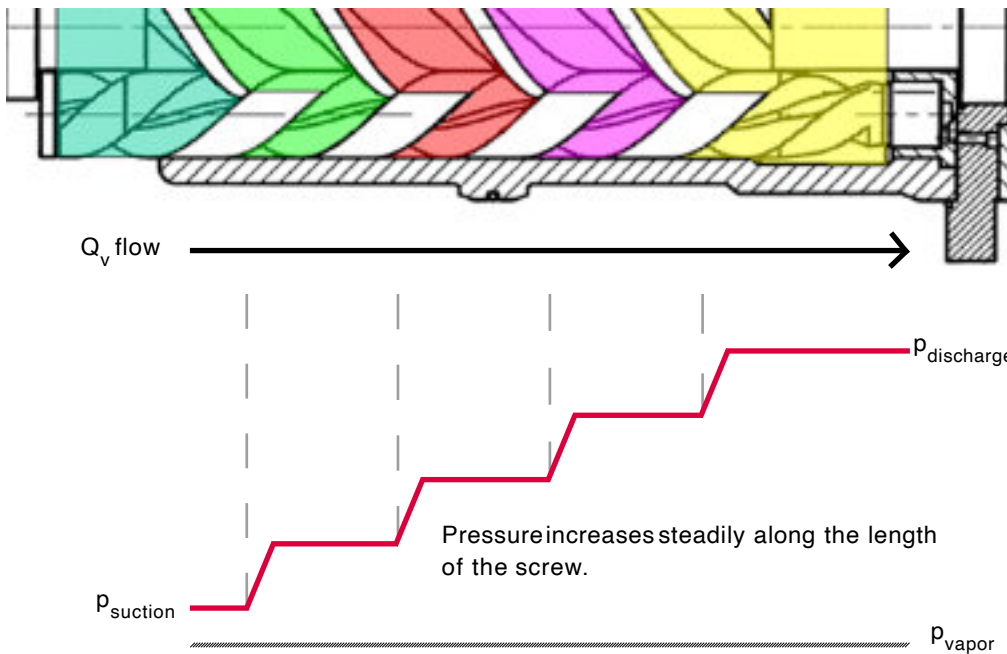

Great control capabilities.

The flow rate of a screw pump is directly proportional to the speed of rotation.

The flow rate can thus be finely adjusted by changing the rotational speed.

In contrast to many other types of pump principles, KRAL screw pumps have linear delivery characteristics. They can therefore be controlled both easily and inexpensively by means of a variable speed drive.

High flow rates and pressures in a compact design.

Low pulsation, low shear liquid transport.

The space needed for setting up or installing pumps can be expensive and is often scarce.

Pressure pulsations in the liquid can damage the pump and the system itself as well as the liquid being pumped.

KRAL screw pumps offer high flow rates with a small footprint in comparison to other pump types.

The amount and intensity of pulsation created depends on the pumping principle. Piston and gear pumps can create considerably higher pulsation than a screw pump.

KRAL screw pumps transport the product being pumped very gently. The liquid is not subjected to shear. There are almost no pressure pulses that can damage the piping and other components or trigger vibrations. In addition, KRAL pumps are very quiet.

■■■■■■ Pumps



C Series – A Proven Pump in Many Fields.



Oil & Gas.

- Series CG (API).
- Pressure up to 1,450 psi.
- Viscosity up to 10,000 cSt

The CG pump is a proven player in the field of oil and gas. They're being used for lubrication, transfer, hydrocarbon and chemical processing, crude oil transport, refining and asphalt.



Marine.

- Series CK, CL, CG.
- Pressure up to 1,450 psi.
- Viscosity up to 10,000 cSt.

C pumps are widely used in the marine industry for fuel, lubrication oil and burner supply as well as in hydraulic applications. For heavy fuel oil (HFO), C pumps are commonly coupled magnetically.



Mechanical Engineering.

- Series CK, CL, CG.
- Pressure up to 1,450 psi.
- Viscosity up to 10,000 cSt.

C pumps are generally used in the mechanical engineering field for lube oil applications and in hydraulic systems.

Power Generation.

- Series CK, CL, CG.
- Pressure up to 1,450 psi.
- Viscosity up to 10,000 cSt.

The main applications for C pumps in power generation is fuel oil transport and transfer, fuel oil injection and burner service as well as lube oil applications.



Chemical Engineering.

- Series CK, CL, CG.
- Pressure up to 1,450 psi.
- Viscosity up to 1,000,000 cSt.

CG pumps are used in the chemical industry in special applications such as with polyurethanes. For toxic liquids like isocyanate, magnetically coupled pumps are common.



Versatility in Matching Customer Requirements.

Standard design, individualized customization and custom engineered solutions.

Our pumps produce the ideal environment for increasing the productivity of equipment and plants. KRAL pumps, pump stations and services are based on innovative technology, tried and tested functionality and outstanding quality. KRAL offers both standard options as well as customer specific designs and solutions.



▶ The mega seller of the C Series.

The CK is the best selling screw pump line of the C series. It is mainly used in hydraulic and lubrication oil applications. Standardized pump/motor brackets made of aluminum are used for the CK pump.

This makes the pump inexpensive and simple to install.



▶ Individual customization.

For the CG pump series, KRAL offers a variety of housings, relief valves and connections. The housing is available in cast iron or steel. Versions with a heating jacket are available for high-viscosity liquids.



▶ Tailor-made solution.

As an example, this picture shows a complete hydraulic system mounted on a frame to provide protection during transportation, maintenance and operation. The compact pump-hydraulic package is completely assembled and

tested at the factory. Simple field connections allow for quick installation and startup. All necessary motor, pump and control components are incorporated into a small footprint with easy access for maintenance.

C Series at a Glance.

The wide range of products in the flexible C series with a variety of pumps and pump stations – here’s an overview.

Variations of the C series.

KRAL screw pumps in the C series are for pumping lubricating, non-abrasive, chemically neutral liquids.

The main components of the C pump line are the same. The CK, CL and CG differ in terms of certain specifications in order to cover varying customer requirements.

The CK is very compact. It's the least expensive model. Its short main screw construction is achieved by using a shaft seal ring. The CK is often supplied with a suction pipe for vertical in-tank installation.

The CL has a longer main screw. It is therefore capable of generating higher pressures and has sufficient space for a wide range of shaft seals.

The CG is a cartridge pump (insert pump) design and offers a variety of options for safety or bypass valves. The outer casing can be either cast iron or fabricated steel. The steel encased version allows for almost any positioning, size and type of liquid connection.

Operation, materials, accessories.	
Flow rate CK:	460 gpm.
Flow rate CL:	940 gpm.
Flow rate CG:	940 gpm.
Temperature:	-5 °F to 480 °F -20°C to 250°C.
Pressure:	up to 1,450 psi up to 100 bar.
Housing:	silafont aluminum alloy (AlSi10Mg), EN-GJS-400, steel.
Screws:	nitrated steel.
Heating system:	electrical or fluid heating.
Medium:	lubricating. non abrasive. chemically neutral.

From the CK through the CL to the CG.

④ Radial shaft seal ring.
The CK series is only available with a radial shaft seal ring.

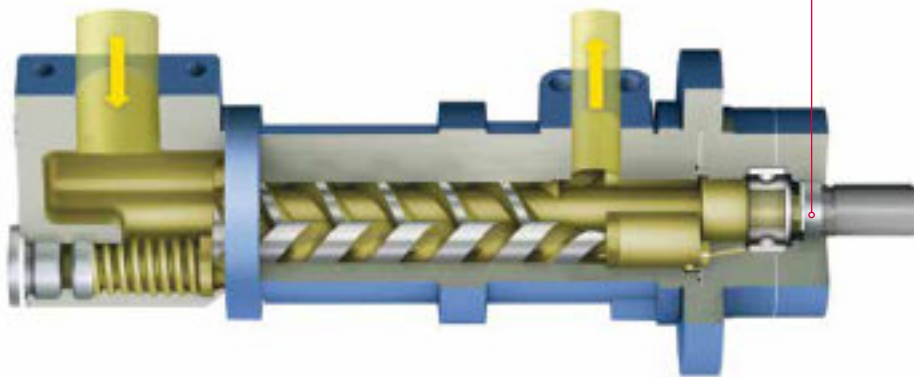

◀ Due to its short shaft, the CK series is only available with a radial shaft seal. The CK has internal bearings and is most often used as a vertical, submerged in-tank pump.

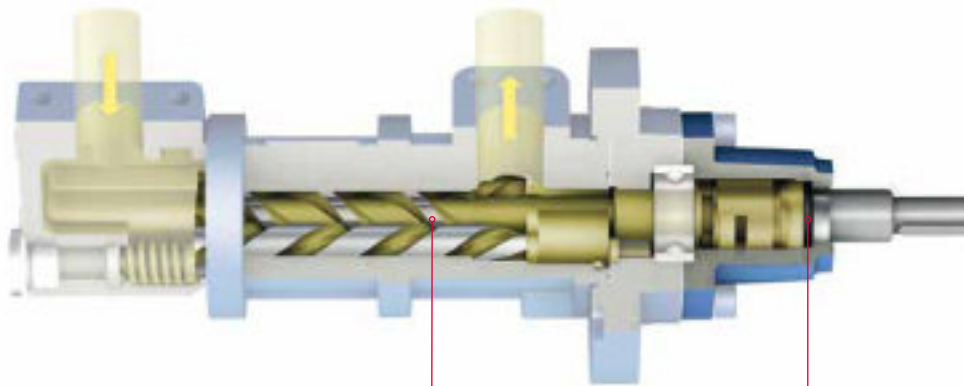

The CL series can be equipped with different shaft sealing options thanks to the longer screw set. External bearings are also possible. This pump line is used as a horizontal or vertical foot-mounted or flange-mounted pump as well as in in-tank vertical arrangements.

◀

The CL pump is the cartridge (insert) pump of the CG series. The various housing options allow enormous flexibility in terms of the liquid connections. An external overflow valve can optionally be attached to the CG pumps.

▶

④ Longer screw set.
Thanks to the longer spindle an external ball bearing is optionally offered (see page 15).

④ Seal housing.
Depending on the operational requirements various shaft seal options are possible for the CL series (see page 15).

④ Flexible connections.

If the outer casing is made from fabricated steel, then almost any positioning, direction, size, type and rating of flange can be achieved (see page 24). It can be ideally suited to match the installation situation.

④ External overflow valve.

The overflow valve ensures that the liquid is rerouted should excess pressurization occur.

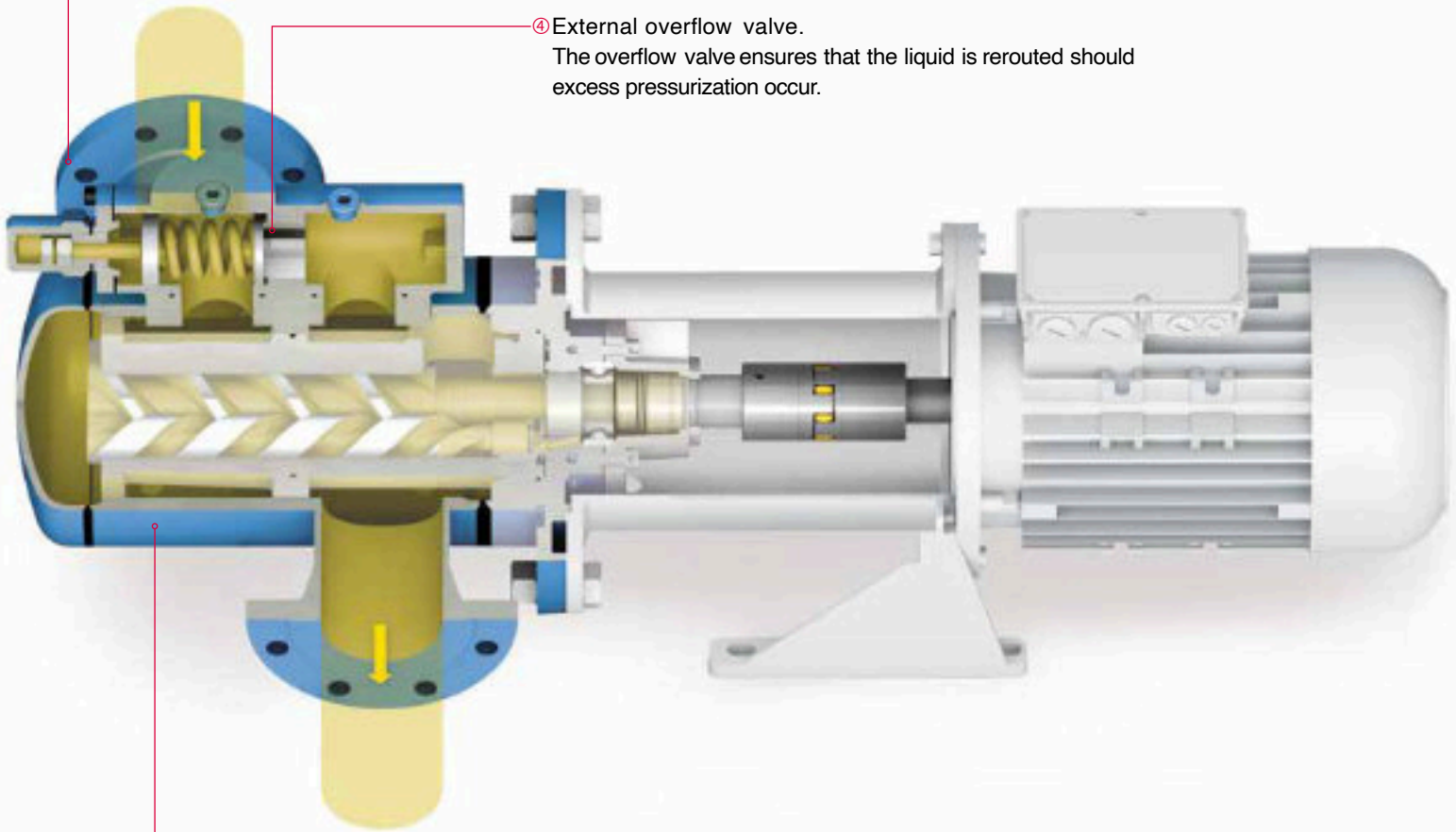

④ Housing variants.

Depending on the operational requirements cast iron or steel housings are offered for the CG series.

■■■■■■■■ Pumps

Innovative Solution - Magnetically Coupled KRAL Pumps.

No seals, leak free and virtually maintenance free.

- No more seal maintenance or seal changing required.
- Completely enclosed – no air or moisture can enter the pump and come into contact with pumped liquid.
- Perfect pump solution for environmentally hazardous, hot or sensitive liquids.
- Hermetically sealed – guaranteed leak free.
- Ideally suited for high inlet pressure applications (compressor/expander lube oil pump).
- Hydraulically balanced due to axial thrust compensation (even at high inlet pressure).
- Long bearing life.

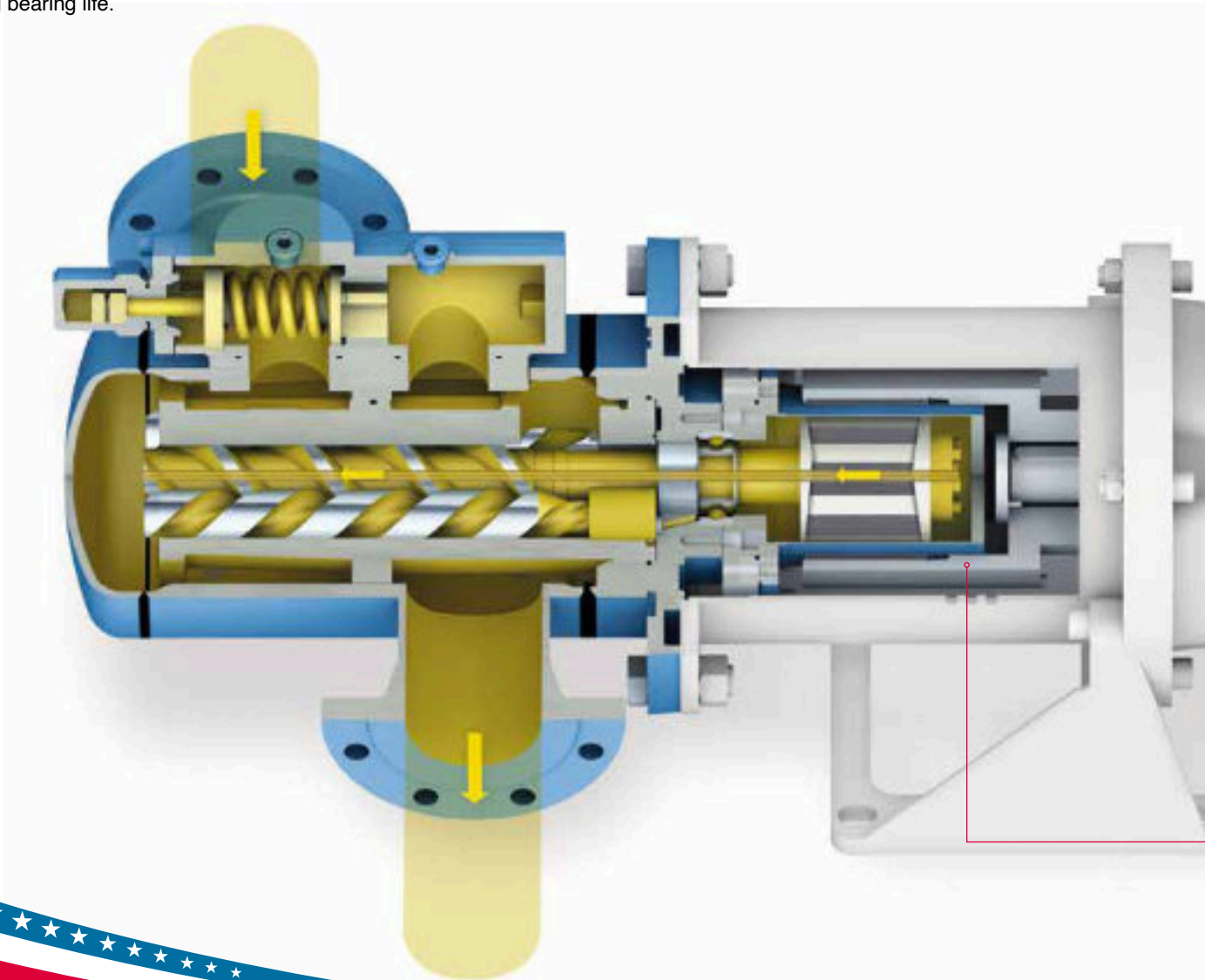

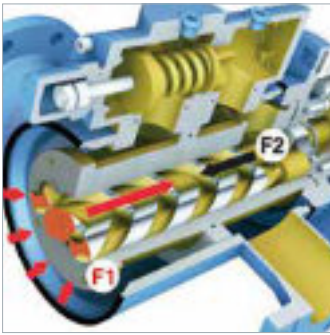

Drive screw.

High inlet pressure acts directly on the face of the main drive screw as well as the idler screws (force F1). Some of the force is compensated for on the pressure side of the main screw (F2), however the resulting axial force would normally create a high axial load on the bearing. This is not the case with a magnetic coupling.

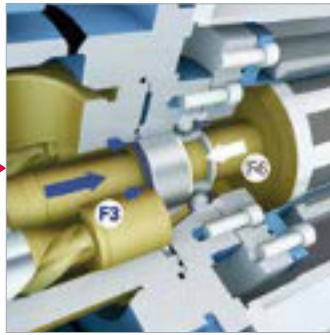

Balancing cylinder.

The balancing cylinder is precisely dimensioned so that the axial forces (F3 and F4) resulting from the pressures acting on its faces largely cancel each other out.

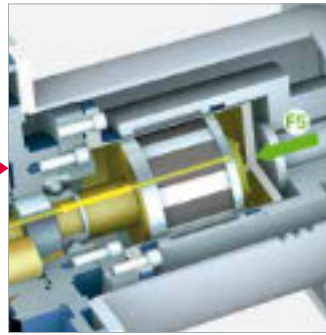

Magnetic coupling.

Thanks to an opening through the center of the drive screw, the suction side pressure conditions are also present within the containment can of the magnetic coupling. Due to this special design, a force F5 is created that compensates for the axial thrust on the main spindle. The load on the bearing is minimized leading to long and trouble free operation.

High inlet pressure.

High inlet pressure causes enormous load on the ball bearing and the mechanical seal.

A conventional pump with high inlet pressure requires expensive mechanical seal solutions, structural reinforcement and liquid channels for hydraulic balancing.

The magnetic coupling design eliminates the axial forces, resulting in only minimal load on the ball bearing due to the geometrical conditions. The life expectancy of the ball bearing is thus independent of the inlet pressure, and the magnetic coupling replaces a costly mechanical seal. This means a better pump solution at a lower cost.

Best material quality.

Highest quality materials can withstand high pressures and guarantee minimal eddy current losses at the magnetic coupling.

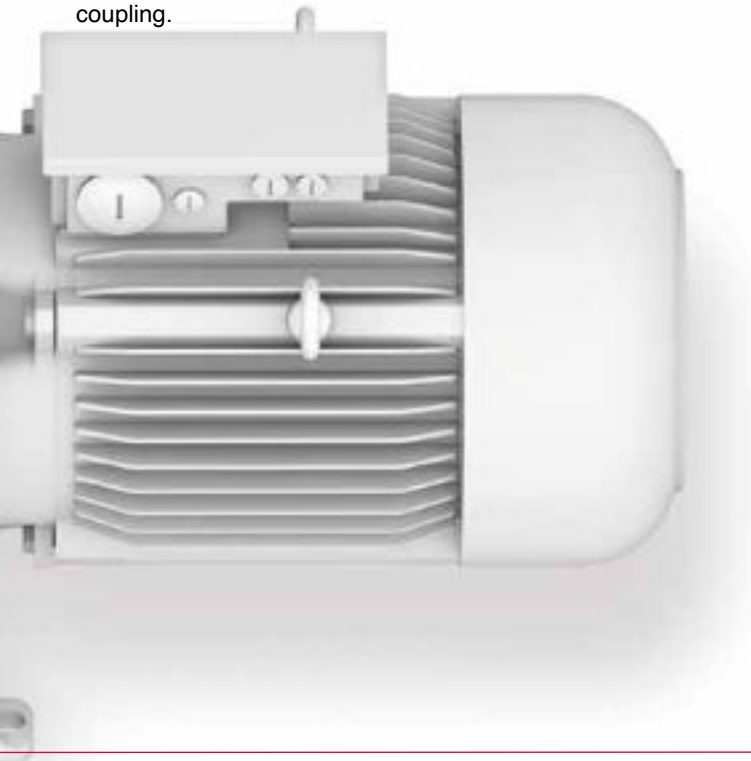

On the Safe Side.

Standards, materials, connections, seal options.



Materials.

Standard housings are made of a special aluminum alloy or cast iron. Fabricated steel casing is available for the CG pump.



Safety.

C pumps can be equipped with an internal overflow valve to protect against overpressure. The CG series furthermore offers optional external overflow or bypass valves.

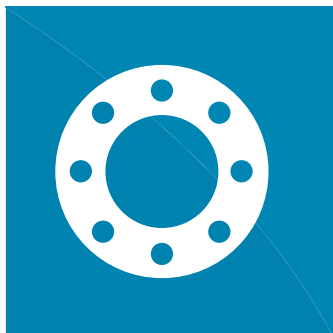

Flanges.

A variety of connections such as ANSI, SAE, EN DIN, JIS (steel housing) are possible for the C series. See page 24 for different possible connection options.

Approvals.	Design standards.
API, CE, ATEX, GOST, ABS, BV, CCS, DNV, GL, LRS, MRS, NK, RINA, KR.	EN 13445 steel housing. EN 13480 pipework.

API standards.	Hazardous locations.
API 676 API 614 API 682 API 685	 Group II, Category 2, Ex II 2 GD b/c.

Magnetic coupling vs. mechanical seal.

External bearings vs. internal bearings.

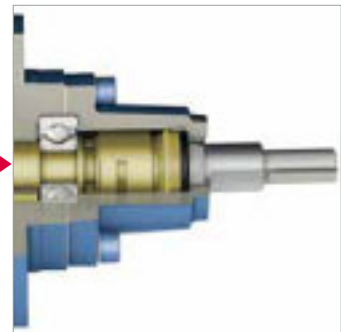
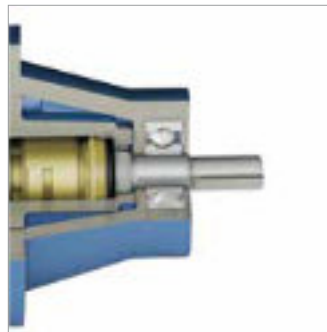
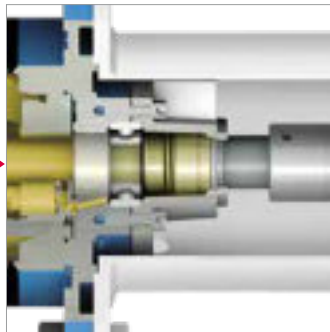
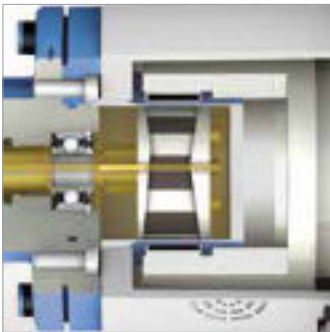

Magnetic coupling.

Mechanical seal.

External bearing.

Internal bearing.

CL/CG pumps can be hermetically sealed thanks to the optional magnetic coupling. This makes the pump completely leak free. The magnetic coupling does not wear and therefore requires no maintenance under normal circumstance.

Operating principle: The motor torque is transferred through the containment can (canister) without contacting the pump screws via a magnetic assembly attached to the motor and to the pump shaft.

The magnetic coupling is also ideally suited for high inlet pressure applications (see page 12-13).

Maximum operating temperature of the pump is increased to 480 °F (250 °C) due to the high temperature capacity of the magnetic coupling.

An unbalanced mechanical seal is standard.

Bidirectional, hard face mechanical seals as well as balanced seals from all major seal manufacturers are options for this pump line.

Seal type and material depends on the pumped liquid, requested standards and the operating conditions.

Pumps with external ball bearings can be used for liquids that harden and tend to crystallize when they cool down, or for abrasive liquids.

Examples are polyol, isocyanate with fillers, bitumen, asphalt, etc.

Reinforced ball bearings are offered for high shaft loads. The external bearing option is available for the CL and CG pump line.

The internal bearing is medium lubricated and standard installed.

Maximum permissible temperature is 350 °F (180 °C).

Reinforced ball bearings are offered for high shaft loads.





■■■■■■■■ Pumps

CK sizes 5 to 118.

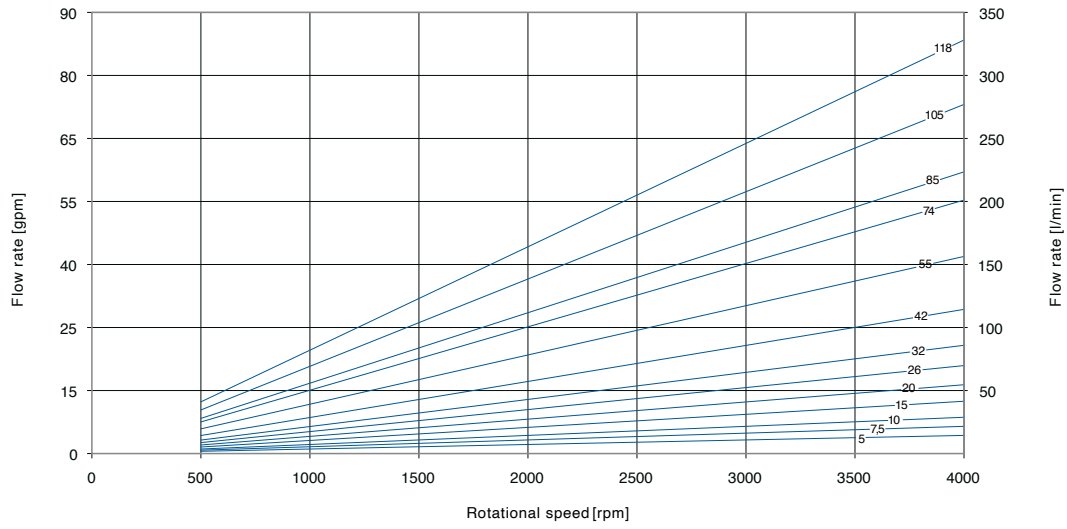

CK sizes 160 to 880.

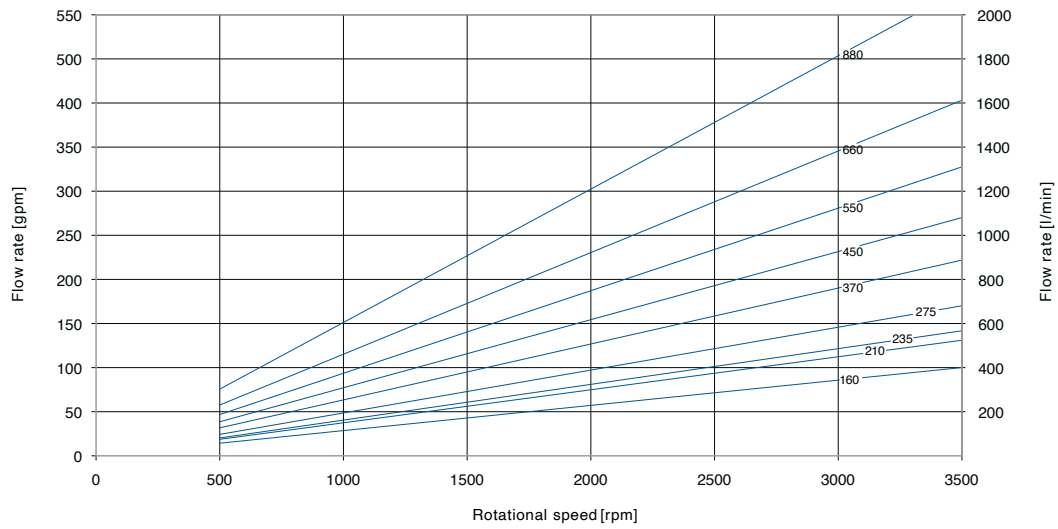

Technical data CK.		5-10	15-26	32-42	55-85	105-118
Q _{th} (1,450 min ⁻¹ , 0 bar)	l/min	5 to 10	15 to 26	32 to 42	55 to 85	105 to 118
Q _{th} (1,750 rpm, 0 psi)	gpm	2 to 3	5 to 8	10 to 14	19 to 27	32 to 38
Max. discharge pressure	psi	1,450	1,015	1,015	1,015	1,015
Temperature	° F					
Radial shaft seal		300	300	300	300	300
Viscosity	cSt					
min.		1.5	1.5	1.5	1.5	1.5
max.		10,000	10,000	10,000	10,000	10,000
Max. pressure at suction flange	psi					
Radial shaft seal		145	145	145	145	145

Technical data CK.		160-210	235-275	370-450	550-880
Q _{th} (1,450 min ⁻¹ , 0 bar)	l/min	160 to 210	235 to 275	370 to 450	550 to 880
Q _{th} (1,750 rpm, 0 psi)	gpm	53 to 69	75 to 90	117 to 143	173 to 279
Max. discharge pressure	psi	1,015	1,015	1,015	580
Temperature	° F				
Radial shaft seal		300	300	300	300
Viscosity	cSt				
min.		1.5	1.5	1.5	1.5
max.		10,000	10,000	10,000	10,000
Max. pressure at suction flange	psi				
Radial shaft seal		145	145	145	145

■■■■■■■■ Pumps

CL sizes 5 to 118.

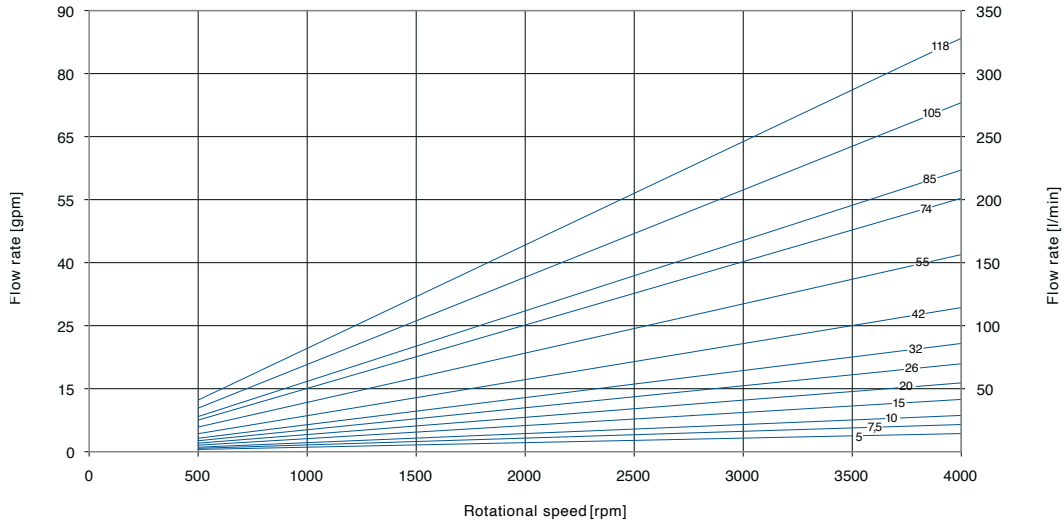

CL sizes 160 to 880.

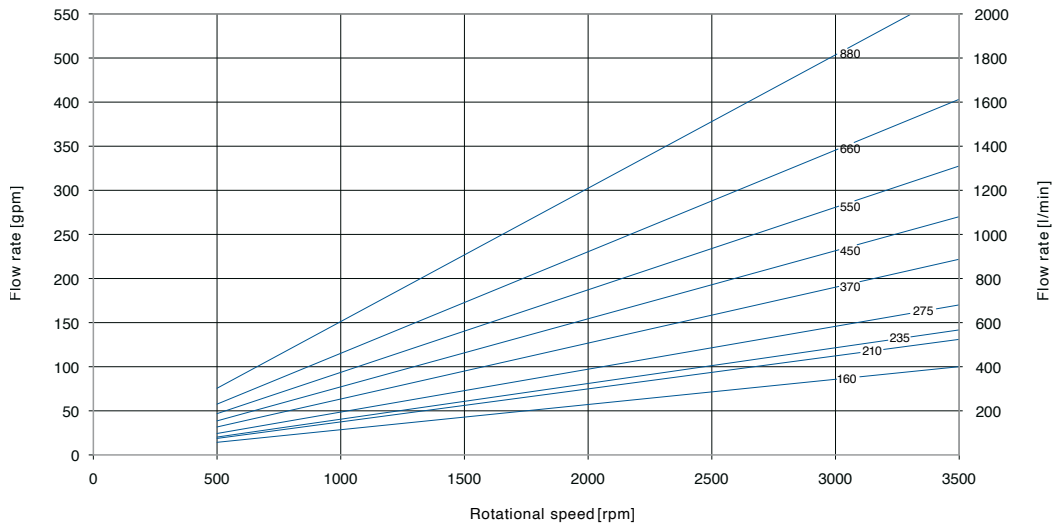

Technical data CL.		5-10	15-26	32-42	55-85	105-118
Q _{th} (1,450 min ⁻¹ , 0 bar)	l/min	5 to 10	15 to 26	32 to 42	55 to 85	105 to 118
Q _{th} (1,750rpm, 0 psi)	gpm	2 to 3	5 to 8	10 to 14	19 to 27	32 to 38
Max. discharge pressure	psi	1,450	1,450	1,450	1,450	1,450
Temperature	° F					
Stuffing box packing		180	180	180	180	180
Radial shaft seal		300	300	300	300	300
Mechanical seal - standard		300	300	300	300	300
Mechanical seal - hard face		360	360	360	360	360
Magnetic coupling		360	360	360	360	360
Viscosity	cSt					
min.		1.5	1.5	1.5	1.5	1.5
max.		10,000	10,000	10,000	10,000	10,000
Max. pressure at suction flange	psi					
Stuffing box packing		45	45	45	45	45
Radial shaft seal		7	7	7	7	7
Mechanical seal		430	430	430	430	430
Magnetic coupling		230	230	230	230	230

Technical data CL.		160-210	235-275	370-450	550-880
Q _{th} (1,450 min ⁻¹ , 0 bar)	l/min	160 to 210	235 to 275	370 to 450	550 to 880
Q _{th} (1,750rpm, 0 psi)	gpm	53 to 69	75 to 90	117 to 143	173 to 279
Max. discharge pressure	psi	1,450	1,450	1,160	1,160
Temperature	° F				
Stuffing box packing		180	180	180	180
Radial shaft seal		300	300	300	300
Mechanical seal - standard		300	300	300	300
Mechanical seal - hard face		360	360	360	360
Magnetic coupling		360	360	360	360
Viscosity	cSt				
min.		1.5	1.5	1.5	1.5
max.		10,000	10,000	10,000	10,000
Max. pressure at suction flange	psi				
Stuffing box packing		45	45	45	45
Radial shaft seal		7	7	7	7
Mechanical seal		430	430	430	430
Magnetic coupling		230	230	230	230

■■■■■■■■ Pumps

CG sizes 15 to 118.

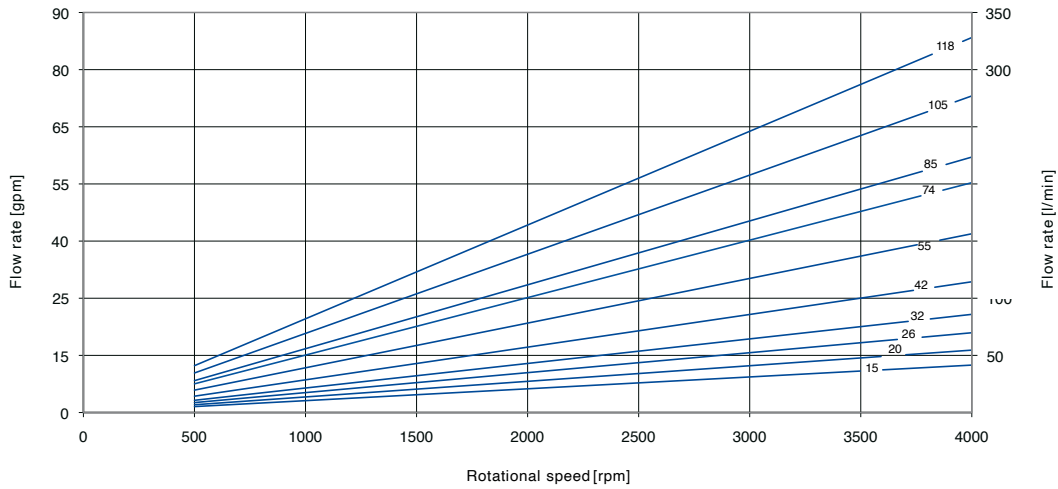

CG sizes 160 to 3550.

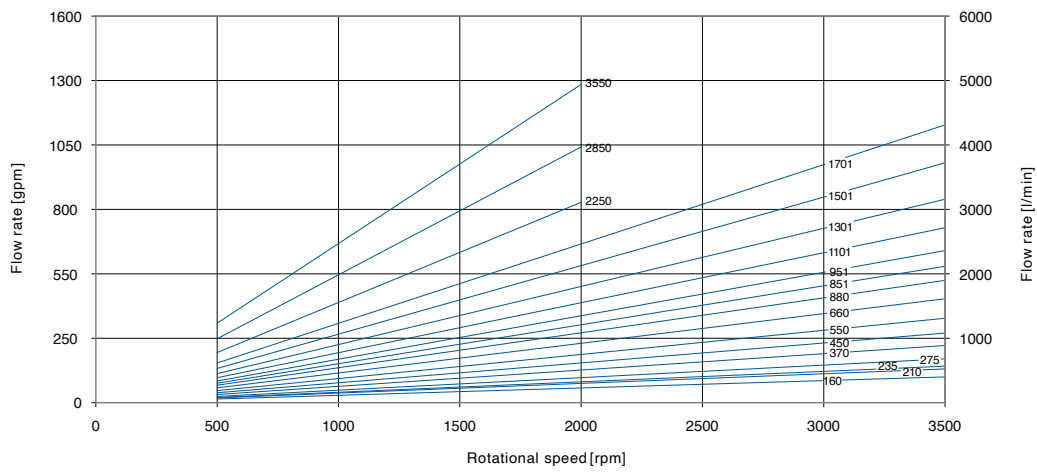

Technical data CG.		15-26	32-42	55-85	105-118	160-210	235-275	370-450
Q _{th} (1,450 min ⁻¹ , 0 bar)	l/min	15 to 26	32 to 42	55 to 85	105 to 118	160 to 210	235 to 275	370 to 450
Q _{th} (1,750 rpm, 0 psi)	gpm	5 to 8	10 to 14	19 to 27	32 to 38	53 to 69	75 to 90	117 to 143
Max. discharge pressure	psi	1,450	1,450	1,450	1,450	1,450	1,450	1,450
Temperature	° F							
Stuffing box packing		180	180	180	180	180	180	180
Radial shaft seal		300	300	300	300	300	300	300
Mechanical seal - standard		300	300	300	300	300	300	300
Mechanical seal - hard face		360	360	360	360	360	360	360
Magnetic coupling*		480	480	480	480	480	480	480
Viscosity	cSt							
min.		1.5	1.5	1.5	1.5	1.5	1.5	1.5
max.		1,000,000	1,000,000	1,000,000	1,000,000	1,000,000	1,000,000	1,000,000
Max. pressure at suction flange	psi							
Radial shaft seal		7	7	7	7	7	7	7
Stuffing box packing		45	45	45	45	45	45	45
Mechanical seal		430	430	430	430	430	430	430
Magnetic coupling*		1,450	1,450	1,450	1,450	1,450	1,450	1,450

Technical data CG.		550-880	851-951	1101-1301	1501-1701	2250-3550
Q _{th} (1,450 min ⁻¹ , 0 bar)	l/min	550 to 880	851 to 951	1101 to 1301	1501 to 1701	2250 to 3550
Q _{th} (1,750 rpm, 0 psi)	gpm	173 to 279	251 to 312	359 to 417	491 to 569	718 to 1141
Max. discharge pressure	psi	1,450	1,450	1,450	1,450	1,450
Temperature	° F					
Stuffing box packing		180	-	-	-	-
Radial shaft seal		300	300	300	300	300
Mechanical seal - standard		300	300	300	300	300
Mechanical seal - hard face		360	360	360	360	360
Magnetic coupling*		480	480	480	480	480
Viscosity	cSt					
min.		1.5	1.5	1.5	1.5	1.5
max.		1,000,000	1,000,000	1,000,000	1,000,000	1,000,000
Max. pressure at suction flange	psi					
Stuffing box packing		45	-	-	-	-
Radial shaft seal		7	7	7	7	7
Mechanical seal		430	430	430	430	430
Magnetic coupling*		1,450	1,450	1,450	1,450	1,450

*Higher values available upon request.

■■■■■■■■ Pumps

Your Choice of Connection.

CG pumps with fabricated steel casing.

Type, orientation, size and class of the flange can be freely selected.

Special setups and adaptations are possible on request.
VIEW IS FROM OPPOSITE OF PUMP SHAFT END.



A) "In-line flanges":
opposing connections.
The connections are opposite of each other with the inlet on the left and the outlet on the right.



B) "In-line flanges":
opposing connections.
The connections are opposite of each other with the inlet on the right and the outlet on the left.



C) "End suction":
axial pump inlet.
The pressure side is on the side or on top. Outlet left.



D) "End suction":
axial pump inlet.
The pressure side is on the side or on top. Outlet right.



E) "90° arrangement".
Inlet on top, outlet right.
Connections can vary depending on the installation position of pump.



F) "90° arrangement".
Inlet on top, outlet left.
Connections can vary depending on the installation position of pump.



G) "90° arrangement".
Inlet right, outlet on top.
Connections can vary depending on the installation position of pump.

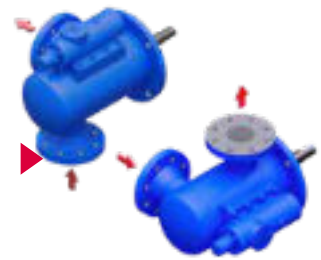

H) "90° arrangement".
Inlet left, outlet on top.
Connections can vary depending on the installation position of pump.

I) "Top flanges": connections on same side (plane).
For example inlet and outlet on top. Pump can be rotated to any installation position.



KRAL

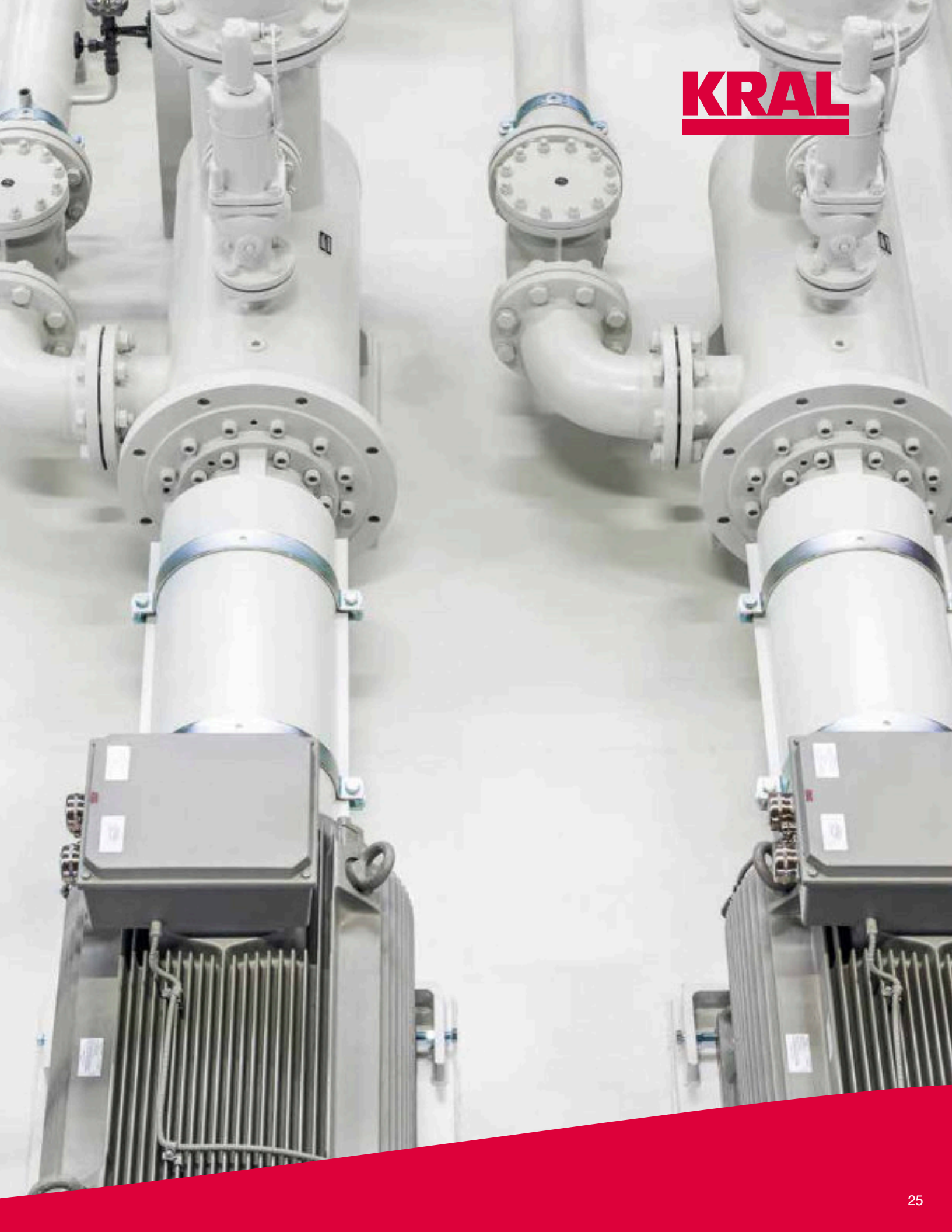

■■■■■■■■ Pumps



The Pump to Match Your Design.

Various models and configurations of KRAL C pumps allow for optimal installation.



▶ CK/CL: Top flange pump – close coupled.
Pump close coupled to motor via pump motor bracket including foot, with top flanges for horizontal installation. Pump inlet connection can be rotated in 90 degree increments.



▶ CG: Horizontal - inline flange pump – close coupled.
Pump close coupled to motor via pump motor bracket including foot, with inline flanges for horizontal installation. Pump can also be installed vertically if required.



▶ CG/CL: inline and top flange, foot mounted pump on base frame.
Pump skid consisting of pump, coupling, coupling guard, base frame and motor. API version available.



▶ CG/CK/CL: Gear box mounted pump.
Pump attached to gear box. Setups with coupling or gear wheel directly mounted to pump shaft possible.



▶ CK/CL: in-tank, vertical pump.
In-tank, vertical, close coupled pump / motor arrangement. Customer specific options include suction pipe, strainer, foot valve, non-return valve, pressure piping with or without safety valve, mounting plate, special connection fittings, etc.



▶ CG: Vertical pedestal pump – close coupled.
Pedestal pump for vertical installation close coupled to motor via pump motor bracket, with inline flanges. This space saving vertical pump is also available with top flanges.



Headquarters

KRAL AG
Bildgasse 40, Industrie Nord
6890 Lustenau, Austria
e-mail: kral@kral.at
Tel.: +43/5577/86644-0

Subsidiaries

KRAL Deutschland GmbH
Competence Center Stadthagen

KRAL Polska Sp. z o.o.
40-668 Katowice

Sister Company

KRAL-USA, Inc.
901A Matthews-Mint Hill Road
28105 Matthews, NC
e-mail: sales@kral-usa.com
Tel.: +1/704/8146164