

KROHNE



OPTIMASS 1400 Technical Datasheet

Sensor for mass flow

- First choice for universal applications
- Best price–performanceratio
- A wide range of options available with no restrictions



The documentation is only complete when used in combination with the relevant documentation for the signal converter.

© KROHNE 05/2019–4004170302–TDOPTIMASS 1400R02 en

 **intercontrol**

Intercontrol

IJsselburcht 26
6825 BP Arnhem
Tel. +31 (0) 26 4425 204

info@intercontrol.eu

1 Product features	3
<hr/>	
1.1 Overview.....	3
1.2 Features and options.....	5
1.3 Meter / converter combinations.....	6
1.4 Measuring principle (twin tube)	6
2 Technical data	8
<hr/>	
2.1 Technical data.....	8
2.2 ATEX temperature limits	12
2.3 Maximum pipework forces (end loadings).....	13
2.4 Guidelines for maximum operating pressure.....	14
2.5 Dimensions and weights	17
2.5.1 Flanged versions	17
2.5.2 NAMUR dimensions	21
2.5.3 Hygienic versions	22
2.5.4 Heating jacket version	25
2.5.5 Purge port option.....	26
3 Installation	27
<hr/>	
3.1 Intended use	27
3.2 Mounting restrictions	27
3.2.1 General installation principles	27
3.2.2 Sunshades	29
4 Notes	30
<hr/>	

1.1 Overview

The OPTIMASS 1400 is the cost effective solution for accurate measurement for a variety of applications. The OPTIMASS 1400 reliably measures massflow, density, volume, temperature, volume concentration or solid content.

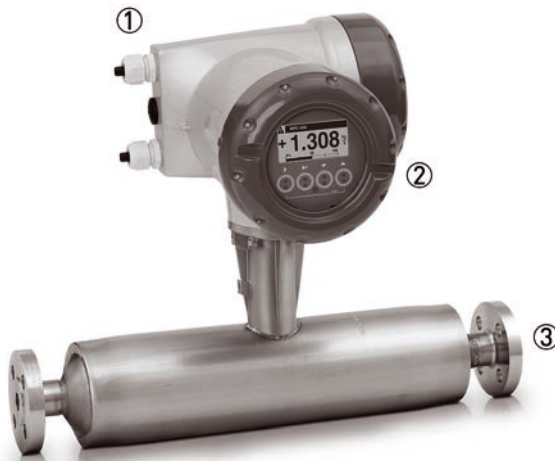

- 1 Modular electronics with a range of output options (see separate documentation for details).
- 2 The power of the MFC 400 gives comprehensive diagnostics together with Entrained Gas Management (EGM).
- 3 Available with a range of flange and hygienic connections.



- 1 Remote terminal box

Highlights

- Innovative twin measuring tubes
- Easily drained and easy to clean
- Resistant to installation and process effects
- Long working life.
- Optimised flow divider for minimum pressure loss.
- High levels of accuracy means an excellent price / performance ratio.
- Modular electronics with data redundancy – "plug & play" replacement of electronics

Industries

- Water & wastewater
- Chemical
- Food & beverage
- Paper & pulp
- Petrochemical industry
- Pharmaceutical industry

Applications

- Suitable for all standard applications up to 130°C
- Hygienic connections make it ideal for food / beverage applications.

1.2 Features and options

Features

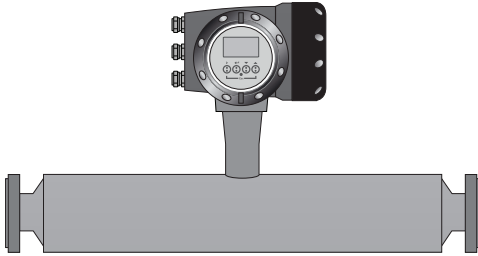

- Available as compact or remote.
- Low pressure loss, guarantees a low pressure drop across the meter.
- Self Draining.
- Easy to clean.

Connection options

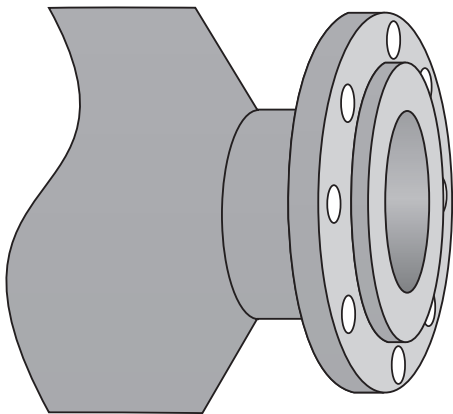

- A range of flanges up to ASME 600 / PN100.
- Supports a wide range of industry standard hygienic connections.
- Adaptable to suit customer's hygienic connections.

Heating jacket & purge port

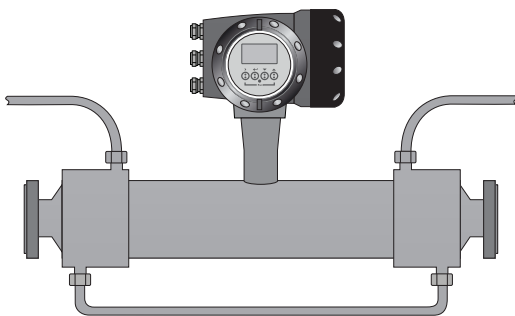

- Heating jacket option for use with temperature dependant products.
- Prevents solidification of process product.
- Purge port option for protection in the event of measuring tube failure.
- Allows hazardous chemicals to be drained away safely.
- Can also be used for the early detection of measuring tube failure where highly toxic chemicals are being measured.

1.3 Meter / converter combinations

Converter	MFC 400	
Configuration	Compact	Remote field
OPTIMASS 1400	1400C	1400F

1.4 Measuring principle (twin tube)

Static meter not energised and with no flow

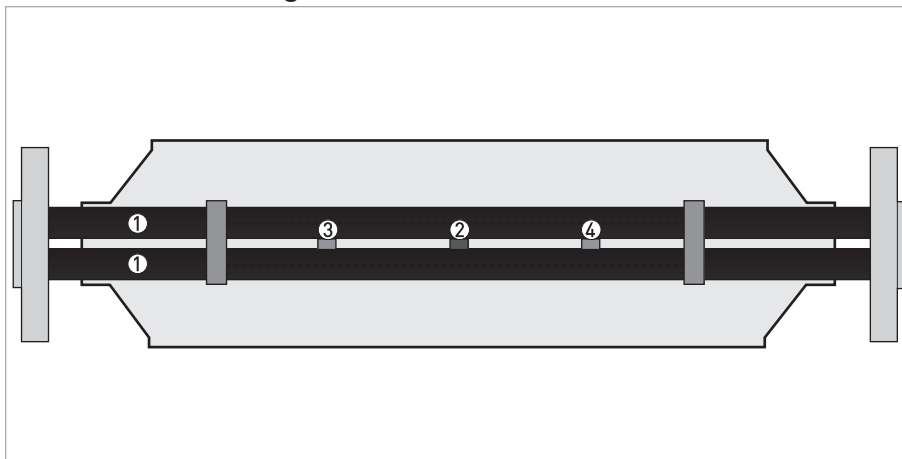

- 1 Measuringtubes
- 2 Drivecoil
- 3 Sensor1
- 4 Sensor2

A Coriolis twin tube mass flowmeter consists of two measuring tubes 1 a drive coil 2 and two sensors (3 and 4) that are positioned either side of the drive coil.

Energised meter

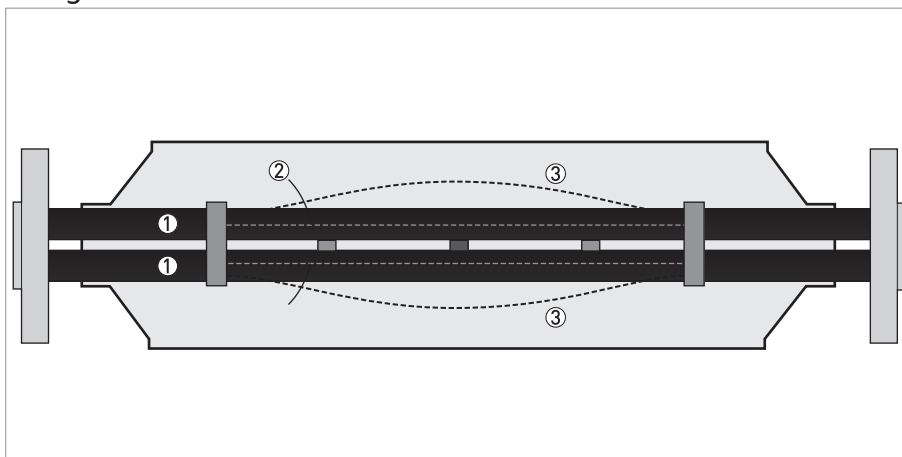

- 1 Measuringtubes
- 2 Direction of oscillation
- 3 Sine wave

When the meter is energised, the drive coil vibrates the measuring tubes causing them to oscillate and produce a sine wave 3. The sine wave is monitored by the two sensors.

Energised meter with process flow

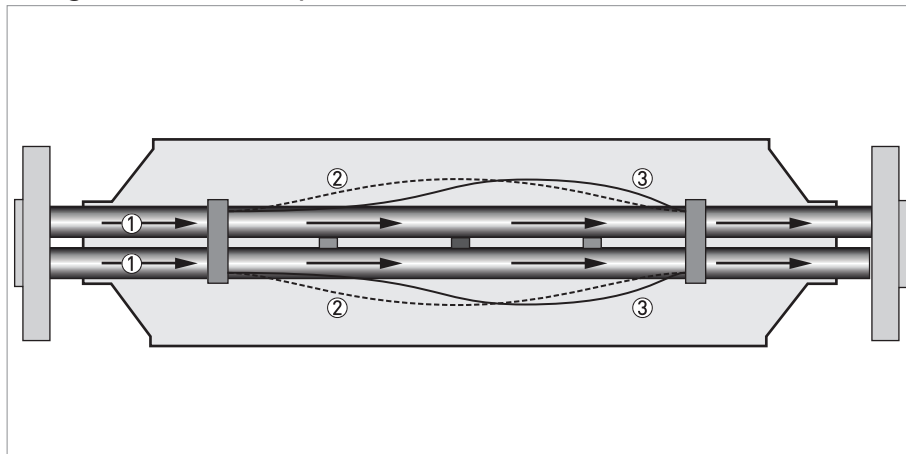

- 1 Process flow
- 2 Sinewave
- 3 Phase shift

When a fluid or gas passes through the tubes, the coriolis effect causes a phase shift in the sine wave that is detected by the two sensors. This phase shift is directly proportional to the mass flow.

Density measurement is made by evaluation of the frequency of vibration and temperature measurement is made using a Pt500 sensor.

2.1 Technical data

- *The following data is provided for general applications. If you require data that is more relevant to your specific application, please contact us or your local sales office.*
- *Additional information (certificates, special tools, software,...) and complete product documentation can be downloaded free of charge from the website (Downloadcenter).*

Measuring system

Measuring principle	Coriolis mass flow
Application range	Mass flow and density measurement of fluids, gases and solids
Measured values	Mass, density, temperature
Calculated values	Volume, referred density, concentration, velocity
Sensor model range	
Stainless Steel S3180315...50	Compact / remote 100 barg @ 20°C / 1450 psig @ 68°F, temp. range -40°C...+130°C / --40°F...+266°F

Design

Basic	System consists of a measuring sensor and a converter to process the output signal
Features	Fully welded maintenance free sensor with twin straight measuring tubes
Variants	
Compact version	Integral converter
Remote version	Available with a field version of the converter

Performance specification

Reference conditions	
Calibration fluid	Water
Calibration temperature	+20°C / +68°F (± 5°C)
Calibration pressure	1...6 barg / 14.5...87 psig
Calibration rig	Accreditation satisfies the requirements of BS EN ISO / IEC 17025
Mass flow	
Liquid	
Base accuracy	±0.15% of actual measured flow rate ±zero stability
Repeatability	Better than 0.075% of actual measured flow rate ±zero stability
Gas	
Base accuracy	±0.5% of actual measured flow rate ±zero stability
Repeatability	Better than 0.2% of actual measured flow rate ±zero stability
Zero stability	
Meter size	
15	0.65 kg/h / 0.024 lb/min
25	2.70 kg/h / 0.099 lb/min
40	8.00 kg/h / 0.294 lb/min
50	17.00 kg/h / 0.625 lb/min

Effect on sensor zero point caused by a deviation in process temperature from zero calibration temperature	
All meter sizes	±0.0075% of nominal flow per 1°C / ±0.0042% of nominal flow per 1°F
Effect on sensor zero point caused by a deviation in process pressure from zero calibration pressure	
All meter sizes	+0.015% of nominal flow per 1 bar / +0.001% of nominal flow per 1 psi
Density	
Measuring range	400...2500 kg/m ³ / 25...155 lb/ft ³
Measurement error	
S15	±5 kg/m ³ / ±0.33 lb/ft ³
S25...50	±2 kg/m ³ / ±0.13 lb/ft ³
Repeatability / on-site calibration	
S15	±2 kg/m ³ / ±0.13 lb/ft ³
S25...50	±0.5 kg/m ³ / ±0.033 lb/ft ³
Process temperature effect of deviation from calibration temperature	
S15	Better than ±0.25 g/l per 1°C / ±0.0156 lb/ft ³ per 1°F
S25...50	Better than ±0.15 g/l per 1°C / ±0.0094 lb/ft ³ per 1°F
Volume flow	
Measurement error and repeatability calculations satisfy the requirements of BS ISO 10790 (most recent and up to date version)	
Temperature	
Measurement error	±1°C / ± 1.8°F of reading

Operating conditions

Nominal flow rates (1 barg / 14.5 psig pressure drop)	
Meter size	
15	4800 kg/h / 176.4 lb/min
25	20000 kg/h / 734.9 lb/min
40	60000 kg/h / 2204.6 lb/min
50	125000 kg/h / 4593 lb/min
Maximum flow rates	
All meters	130% of nominal flow rate

Environmental

Ambient temperature	
Compact version with Aluminium converter	-40...+60°C / -40...+140°F
	Extended temperature range: +65°C / +149°F for some I/O options. For more information contact manufacturer.
Compact version with Stainless Steel converter	-40...+55°C / -40...+130°F
Remote versions	-40...+65°C / -40...+149°F
Process temperature	
Flanged connection	-40...+130°C / -40...+266°F
Hygienic connection	-40...+130°C / -40...+266°F
Hazardous Area versions	Refer to temperature limits
Protection category (Acc. to EN 60529)	IP 66 / 67, NEMA 4X
Vibration (acc IEC 60068-2-6)	10-150-10Hz with 0.15 mm for 10...60 Hz, 20 m/s ² for 60...150 Hz

Process temperatures	
Flanged connection	-40...+130°C / -40...+266°F
Hygienic connection	-40...+130°C / -40...+266°F
Nominal pressure at 20°C / 68°F	
Measuring tube	SS 316 / 316L
FM / PED	-1...100 barg / -14.5...1450 psig
CRN / ASME B31.3	-1...100 barg / -14.5...1450 psig
If the process temperature is higher than 20°C / 68°F, the burst pressure will be lower. For more information please contact the manufacturer.	
Fluid properties	
Permissible physical condition	Liquids, gases, slurries
Permissible gas content (volume)	Contact manufacturer for information.
Permissible solid content (volume)	Contact manufacturer for information.
Installation conditions	
Inlet / outlet runs	None required

Materials

Measuring tubes	Stainless Steel UNS S31803(1.4462)
Spigots	Stainless Steel 316 / 316L(CF3M / 1.4409)dual certified
Flanges	Stainless Steel 316 / 316L(1.4401/ 1.4404)dual certified
Outer cylinder	Stainless Steel 304 / 304L(1.4301/ 1.4307)dual certified
	Optional Stainless Steel 316 / 316L(1.4401/ 1.4404)dual certified
Heating jacket version	
Heating jacket	Stainless Steel 316L(1.4404)
	The outer cylinder is in contact with the heating medium
All versions	
Junction box(remote version)	Die cast Aluminium (polyurethane coating)
	Optional Stainless Steel 316(1.4401)

Process connections

Flange	
DIN	DN15...80 / PN40...100
ASME	½...3" / ASME 150...600
JIS	15...80A / 10...20K
Hygienic	
Tri-clover	1...3"
Tri-clamp DIN 32676	DN25...80
Tri-clamp ISO 2852	1...3"
DIN 11864-2Form A	DN25...80
Male thread DIN 11851	DN25...80
Male thread SMS	1...3"

Electrical connections

Electrical connections	For full details, including: power supply, power consumption etc., see technical data for the relevant signal converter.
I/O	For full details of I/O options, including data streams and protocols, see technical data for the relevant signal converter.

Approvals

CE	The device fulfils the statutory requirements of the CE directive. The manufacturer certifies that these requirements have been met by applying the CE mark.
CRN	acc to: ASME B31.3 (most recent and up to date version)
NACE	MR0175/ISO 15156("Sulphide Stress Corrosion Cracking Resistant Metallic Materials for Oil Field Equipment") and MR0103("Materials Resistant to Sulfide Stress Cracking in Corrosive Petroleum Refining Environments") (most recent and up to date versions)
ATEX (most recent and up to date version)	
OPTIMASS 1400Cnon Ex i signal outputs without heating jacket / insulation	
Ex d connection compartment	II 1/2G Ex d ia IIC T6...T1 Ga/Gb
	II 2 D Ex tb IIIC T165°C Db
Ex e connection compartment	II 1/2G Ex de ia IIC T6...T1 Ga/Gb
	II 2 D Ex tb IIIC T165°C Db
OPTIMASS 1400Cnon Ex i signal outputs with heating jacket / insulation	
Ex d connection compartment	II 1/2G Ex d ia IIC T6...T1 Ga/Gb
	II 2 D Ex tb IIIC T165°C Db
Ex e connection compartment	II 1/2G Ex de ia IIC T6...T1 Ga/Gb
	II 2 D Ex tb IIIC T165°C Db
OPTIMASS 1400CEx i signal outputs without heating jacket / insulation	
Ex d connection compartment	I 1/2(1)G Ex d ia [ia Ga] IIC T6...T1 Ga/Gb
	II 2(1) D Ex tb [ia Da] IIIC T165°C Db
Ex e connection compartment	I 1/2(1)G Ex de ia [ia Ga] IIC T6...T1 G
	II 2(1) D Ex tb [ia Da] IIIC T165°C Db
OPTIMASS 1400C Ex i signal outputs with heating jacket / insulation	
Ex d connection compartment	I 1/2(1)G Ex d ia [ia Ga] IIC T6...T1 Ga/Gb
	II 2(1) D Ex tb [ia Da] IIIC T165°C Db
Ex e connection compartment	I 1/2(1)G Ex de ia [ia Ga] IIC T6...T1 G
	II 2(1) D Ex tb [ia Da] IIIC T165°C Db

2.2 ATEX temperature limits

Ambient temp. T_{amb} °C	Medium temp. T_m °C	Temp. class	Max. Surface temp. °C
OPTIMASS 1400C–with or without heating jacket / insulation			
40	40	T6	T75
	55	T5	T90
	90	T4	T125
	130	T3 – T1	T165
50	55	T5	T90
	90	T4	T125
	130	T3 – T1	T165
65	75	T4	T110
	130	T3 – T1	T165
OPTIMASS 1400C–aluminium converter housing –with or without heating jacket / insulation			
40	40	T6	T75
	55	T5	T90
	90	T4	T125
	130	T3 – T1	T165
50	55	T5	T90
	90	T4	T125
	130	T3 – T1	T165
65	65	T4 – T1	T100
OPTIMASS 1400C–SS converter housing –with or without heating jacket / insulation			
40	40	T6	T75
	55	T5	T90
	90	T4	T125
	130	T3 – T1	T165
50	55	T5	T90
	90	T4 – T1	T125
60	60	T5 – T1	T95

2.3 Maximum pipework forces (end loadings)

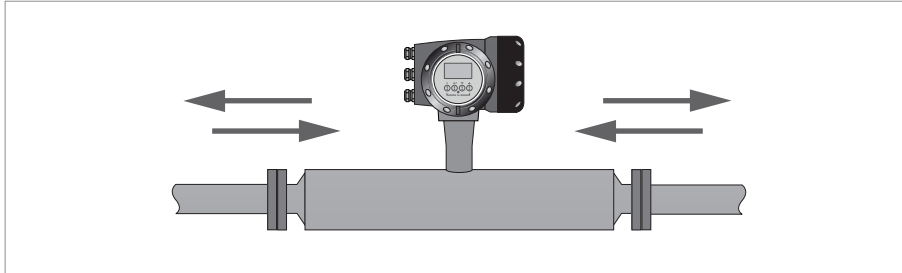

Mass flowmeters have a maximum level of force (negative or positive) that can be applied to the ends of the meter. Refer to the table below for permitted forces.

Maximum end loadings

		S15	S25	S40	S50
Flanges					
20°C	40 barg	25kN	38kN	48kN	99kN
	100 barg	17kN	19kN	15kN	20kN
130°C	32 barg	18kN	28kN	35kN	72kN
	80 barg	12kN	12kN	7kN	8kN
Hygienic (all connections)					
130°C	40 barg	3kN	5kN	N/A	N/A
	25 barg	N/A	N/A	9kN	N/A
	16 barg	N/A	N/A	N/A	9kN

- These (axial) loads have been calculated, based on 316L schedule 40 process pipework, where un-radiographed butt welds have been used in pipe joints.
- The loads shown are the maximum permitted static load. If loads are cycling (between tension and compression) these loads should be reduced. For advice, consult the manufacturer.

2.4 Guidelines for maximum operating pressure

Notes:

- Ensure that the meter is used within its operating limits
- All hygienic process connections have a maximum operating rating of 10 barg at 130°C / 145 psig at 266°F

Pressure / temperature de-rating, all meter sizes, in metric (flanged connections as per EN 1092-1)

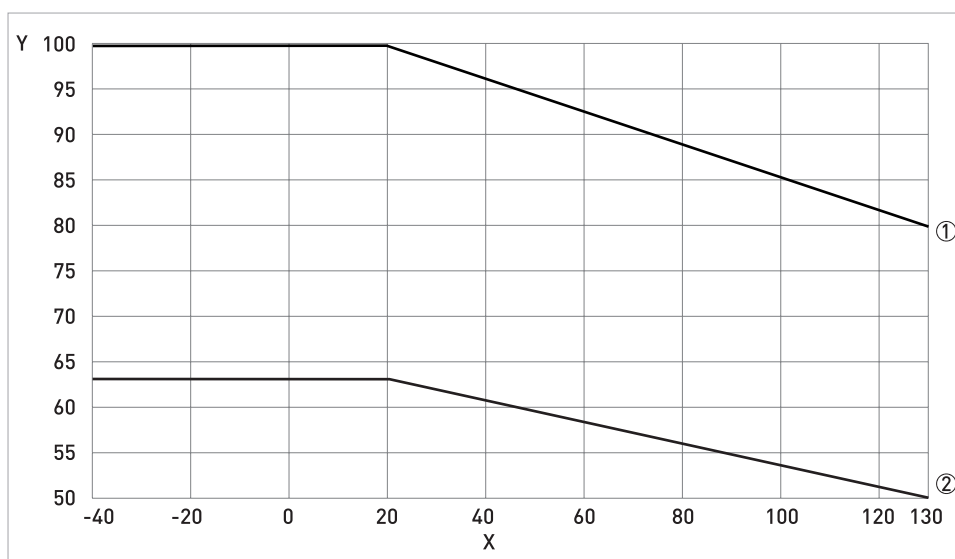

X temperature [°C]

Y pressure [barg]

- 1 Measuring tubes and 100barg 316L secondary containment (PED)
- 2 63 barg 304L / 316 secondary containment (PED)

Pressure / temperature de-rating, all meter sizes, in imperial (flanged connections as per ASME B16.5)

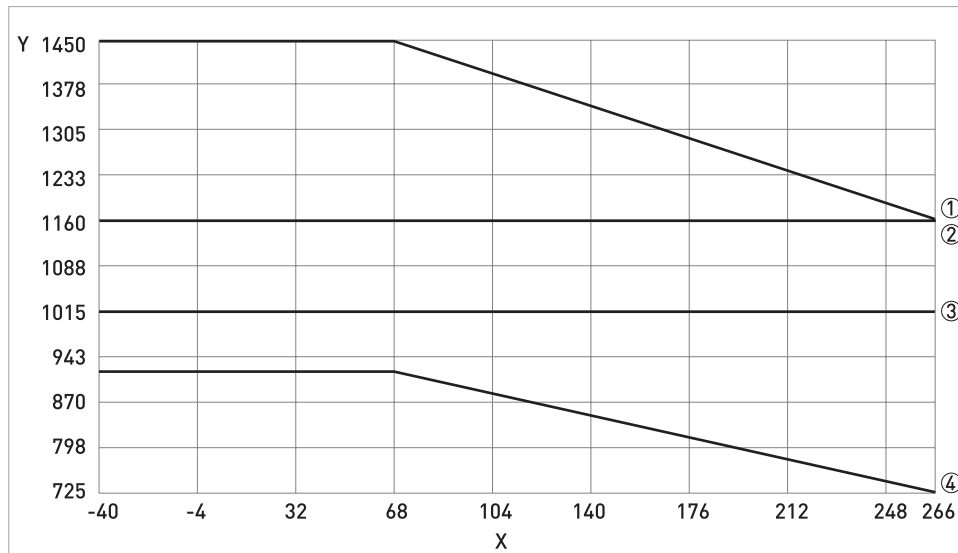

X temperature [°F]

Y pressure [psig]

- 1 Measuring tubes S15 /S25 (CRN)
- 2 Measuring tubes S40 (CRN)
- 3 Measuring tubes S50 (CRN)
- 4 Secondary containment 304L / 316L (CRN)

Flanges

- DIN flange ratings are based on EN 1092-12001 table 18 (1% proof stress) material group 14EO
- ASME flange ratings are based on ASME B16.5 2003 table 2 material group 2.2
- JIS flange ratings are based on JIS 2220:2001 table 1 division 1 material group 022a

Pressure / temperature de-rating(metric) for meters with hygienic connections.

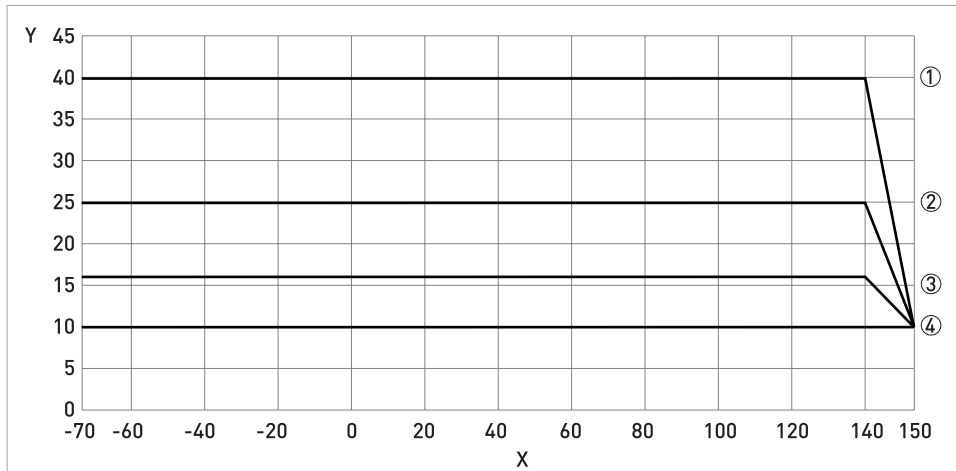

X temperature [°C]
Y pressure [barg]

- 1 SMS 1...1½", DIN 11851DN10...40
- 2 SMS 2", Tri-clamp DN10...40, DIN 11864-2DN10...40, DIN 11851DN50...65
- 3 SMS 3", Tri-clamp DN50...65, DIN11864-2, DIN11864-2DN50...100, DN11851DN80...100
- 4 SMS 4", Tri-clamp DN80...100

Pressure / temperature de-rating(imperial) for meters with hygienic connections.

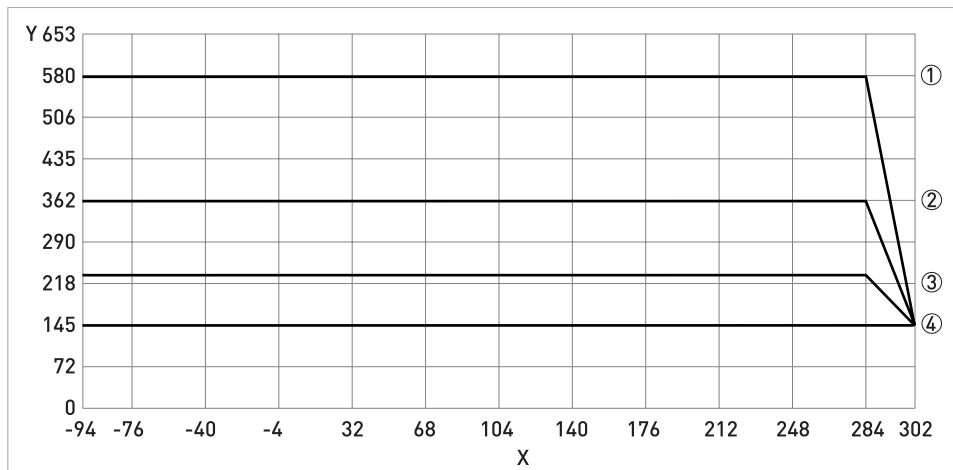

X temperature [°F]
Y pressure [psig]

- 1 SMS 1...1½", DIN 11851DN10...40
- 2 SMS 2", Tri-clamp DN10...40, DIN 11864-2DN10...40, DIN 11851DN50...65
- 3 SMS 3", Tri-clamp DN50...65, DIN11864-2, DIN11864-2DN50...100, DN11851DN80...100
- 4 SMS 4", Tri-clamp DN80...100

Notes

- The maximum operating pressure will be either the flange rating or the measuring tube rating, **WHICHEVER IS THE LOWER!**
- The manufacturer recommends that the seals are replaced at regular intervals. This will maintain the hygienic integrity of the connection.

2.5 Dimensions and weights

2.5.1 Flanged versions

Meter weights (all flanges)

	kg			
	S15	S25	S40	S50
Aluminium (compact)	13.5	16.5	29.5	57.5
Stainless Steel (compact)	18.8	21.8	34.8	62.8
Aluminium (remote)	11.5	14.5	25.5	51.5
Stainless Steel (remote)	12.4	15.4	26.4	52.4

	lbs			
	S15	S25	S40	S50
Aluminium (compact)	30	36.3	65	127
Stainless Steel (compact)	41	48	77	138
Aluminium (remote)	25	32	56	113
Stainless Steel (remote)	27	33.8	58	115

Meter dimensions

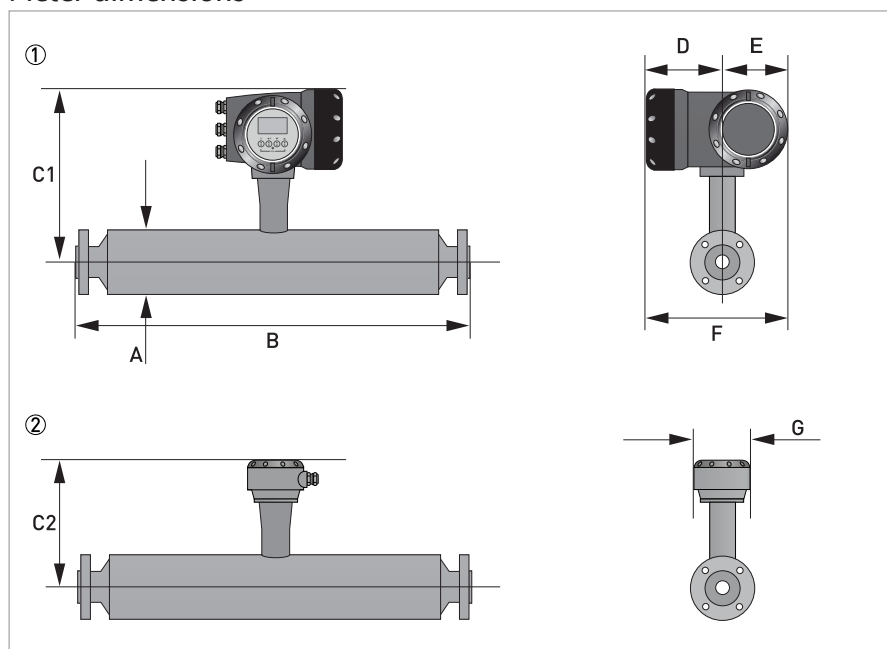

- 1 Compactversion
- 2 Remoteversion

General dimensions

	mm			
	S15	S25	S40	S50
A	101.6	114.3	168.3	219.1
C1 (compact)	311	317	344	370
C2 (remote)	231	237	264	290
D	137			
E	123.5			
F	260.5			
G	118			

	Inches			
	S15	S25	S40	S50
A	4	4.5	6.6	8.6
C1 (compact)	12.2	12.5	13.5	14.6
C2 (remote)	9	9.3	10.4	11.4
D	5.4			
E	4.9			
F	10.2			
G	4.6			

Dimension B

	mm (±5)			
	S15	S25	S40	S50
PN140				
DN15	499	-	-	-
DN25	503	531	-	-
DN40	513	541	706	-
DN50	-	547	712	862
DN80	-	-	732	882
DN100	-	-	-	896
PN163				
DN50	-	-	740	890
DN80	-	-	-	910
PN100				
DN15	513	-	-	-
DN25	539	567	-	-
DN40	-	575	740	-
DN50	-	-	752	902
DN80	-	-	-	922

	mm (±5)			
	S15	S25	S40	S50
ASME 150(Raised Face)				
½"	519	-	-	-
¾"	529	-	-	-
1"	535	563	-	-
1½"	-	575	740	-
2"	-	579	744	894
3"	-	-	756	906
4"	-	-	-	920
ASME 300(Raised Face)				
½"	529	-	-	-
¾"	539	-	-	-
1"	547	575	-	-
1½"	-	589	754	-
2"	-	-	756	906
3"	-	-	-	926
ASME 600(Raised Face)				
½"	541	-	-	-
¾"	551	-	-	-
1"	561	589	-	-
1½"	-	605	770	-
2"	-	-	776	926
3"	-	-	-	946
JB 100K				
50A	-	-	696	846
80A	-	-	-	856
JB 200K				
15A	491	-	-	-
25A	499	527	-	-
40A	-	533	698	-
50A	-	-	700	850
80A	-	-	-	868

	Inches (±0.2)			
	S15	S25	S40	S50
PN40				
DN15	19.6	-	-	-
DN25	19.8	21	-	-
DN40	20.2	21.3	27.8	-
DN50	-	21.5	28	33.9
DN80	-	-	28.8	34.7

	Inches (±0.2)			
	S15	S25	S40	S50
DN100	-	-	-	35.3
PN16				
DN50	-	-	29	35
DN80	-	-	-	35.8
PN100				
DN15	20.2	-	-	-
DN25	21.2	22.3	-	-
DN40	-	22.6	29	-
DN50	-	-	29.6	35.5
DN80	-	-	-	36.3
ASME 150(Raised Face)				
½"	20.4	-	-	-
¾"	20.8	-	-	-
1"	21	22.2	-	-
1½"	-	22.5	29.1	-
2"	-	22.8	29.3	35.2
3"	-	-	29.8	35.7
4"	-	-	-	36.2
ASME 300(Raised Face)				
½"	20.8	-	-	-
¾"	21.2	-	-	-
1"	21.5	22.6	-	-
1½"	-	23.2	29.7	-
2"	-	-	29.8	35.7
3"	-	-	-	36.4
ASME 600(Raised Face)				
½"	21.3	-	-	-
¾"	21.6	-	-	-
1"	22	23.2	-	-
1½"	-	23.8	30.3	-
2"	-	-	30.5	36.4
3"	-	-	-	37.2
JIS 10K				
50A	-	-	27.4	33.3
80A	-	-	-	33.7
JIS 20K				
15A	19.3	-	-	-
25A	19.6	20.7	-	-
40A	-	21	27.5	-
50A	-	-	27.6	33.5
80A	-	-	-	34.2

2.5.2 NAMUR dimensions

The following face to face dimensions comply with NAMUR NE132

	mm (± 3)			
	S15	S25	S40	S50
PN40				
DN15	510	-	-	-
DN25	-	600	-	-
DN40	-	-	715	-
DN80	-	-	-	915

	Inches (± 0.12)			
	S15	S25	S40	S50
PN40				
DN15	20.1	-	-	-
DN25	-	23.6	-	-
DN40	-	-	28.1	-
DN80	-	-	-	36.0

2.5.3 Hygienic versions

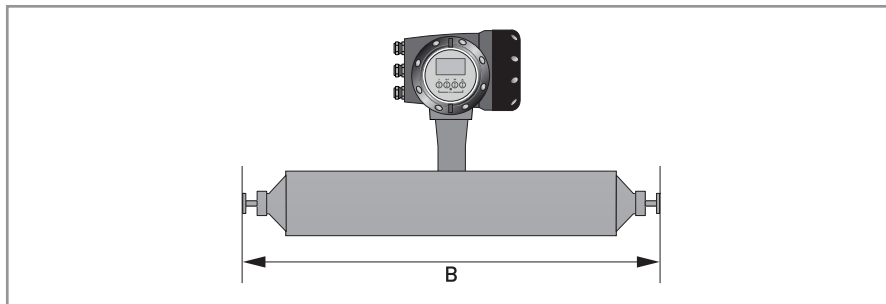

Dimension B: clamp versions

	mm (±5)			
	S15	S25	S40	S50
Tri-clamp				
1"	488	-	-	-
1½"	-	534	-	-
2"	-	-	691	-
3"	-	-	-	832
Tri-clamp DIN 32676				
DN10	-	-	-	-
DN15	-	-	-	-
DN25	468	-	-	-
DN40	-	515	-	-
DN50	-	-	677	-
DN80	-	-	-	836
Tri-clamp ISO 2852				
1"	474	-	-	-
1½"	-	502	-	-
2"	-	-	667	-
3"	-	-	-	817
DIN 11864-2form A				
DN25	505	-	-	-
DN40	-	562	-	-
DN50	-	-	724	-
DN80	-	-	-	896

	Inches (±0.2)			
	S15	S25	S40	S50
Tri-clamp				
1"	19.2	-	-	-
1½"	-	21	-	-
2"	-	-	27.2	-

	Inches (±0.2)			
	S15	S25	S40	S50
3"	-	-	-	32.7
Tri-clamp DIN 32676				
DN10	-	-	-	-
DN15	-	-	-	-
DN25	18.4	-	-	-
DN40	-	20.3	-	-
DN50	-	-	26.6	-
DN80	-	-	-	32.9
Tri-clamp ISO 2852				
1"	18.6	-	-	-
1½"	-	19.8	-	-
2"	-	-	26.3	-
3"	-	-	-	32.2
DIN 11864-2form A				
DN25	19.9	-	-	-
DN40	-	22.2	-	-
DN50	-	-	28.5	-
DN80	-	-	-	35.3

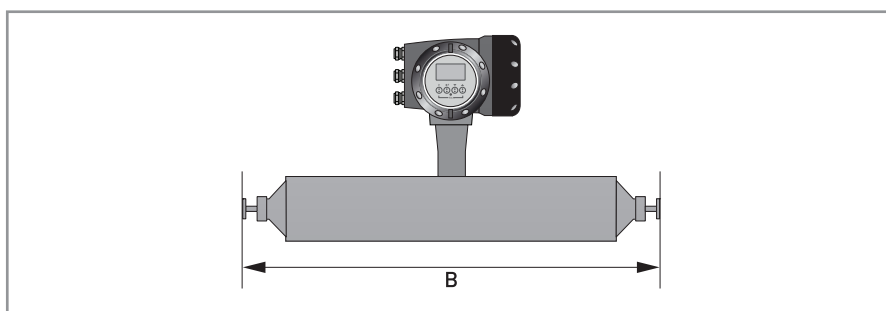

Dimension B: adapter versions (male thread)

	mm (±5)			
	S15	S25	S40	S50
Male thread DIN 11851				
DN25	483	-	-	-
DN40	-	538	-	-
DN50	-	-	704	-
DN80	-	-	-	870
Male thread SMS				
1"	475	-	-	-
1½"	-	537	-	-
2"	-	-	694	-
3"	-	-	-	837
Male thread IDF/ISS				
1"	487	-	-	-
1½"	-	534	-	-
2"	-	-	691	-
3"	-	-	-	832
Male thread RJT				
1"	498	-	-	-
1½"	-	545	-	-
2"	-	-	702	-
3"	-	-	-	843

	Inches (±5)			
	S15	S25	S40	S50
Male thread DIN 11851				
DN25	19	-	-	-
DN40	-	21.2	-	-
DN50	-	-	27.7	-
DN80	-	-	-	34.2
Male thread SMS				
1"	18.7	-	-	-
1½"	-	21.1	-	-

	Inches (±5)			
	S15	S25	S40	S50
2"	-	-	27.3	-
3"	-	-	-	32.9
Male thread IDF/ISS				
1"	19.2	-	-	-
1½"	-	21	-	-
2"	-	-	27.2	-
3"	-	-	-	32.7
Male thread RJT				
1"	19.6	-	-	-
1½"	-	21.4	-	-
2"	-	-	27.6	-
3"	-	-	-	33.2

2.5.4 Heating jacket version

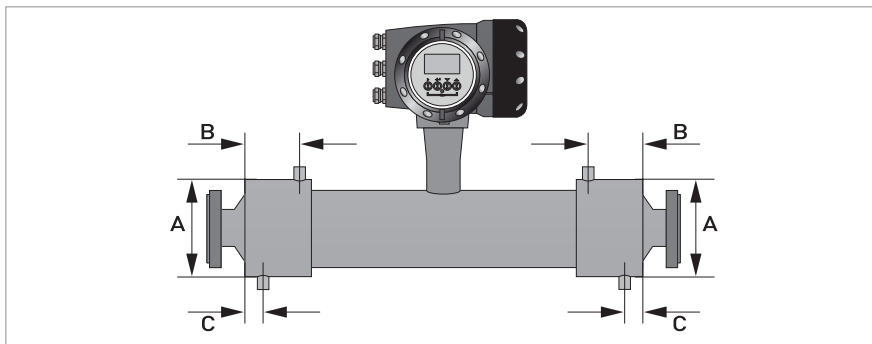

	Dimensions [mm]			
	S15	S25	S40	S50
Heating connection size	12 mm (ERMETO)			25
A	115 ±1	142 ±1	206 ±1	254 ±1
B	51	55	90	105
C	20			26

	Dimensions [inches]			
	S15	S25	S40	S50
Heating connection size	½" (NPTF)			1
A	4.5 ±0.04	5.6 ±0.04	8.1 ±0.04	10 ±0.04
B	2.0	2.2	3.5	4.1
C	0.8			1.0

2.5.5 Purge port option

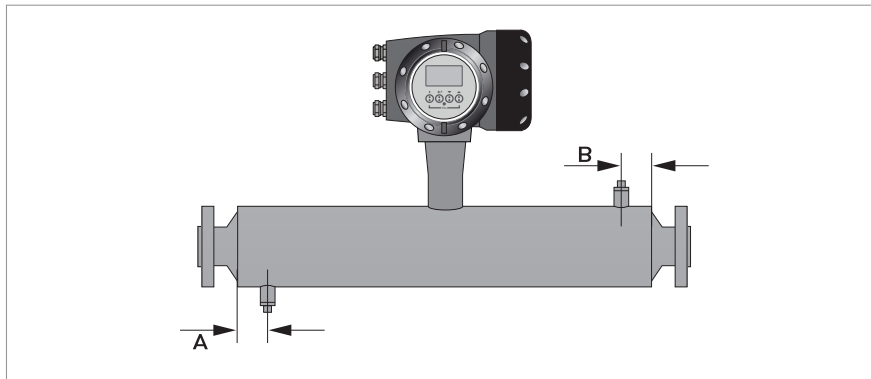

	Dimensions [mm]			
	S15	S25	S40	S50
A	55 ±1.0		65 ±1.0	
B	55 ±1.0		65 ±1.0	

	Dimensions [inches]			
	S15	S25	S40	S50
A	2.2 ±0.04		2.5 ±0.04	
B	2.2 ±0.04		2.5 ±0.04	

3.1 Intended use

This mass flowmeter is designed for the direct measurement of mass flow rate, product density and product temperature. Indirectly, it also enables the measurement of parameters like total mass, concentration of dissolved substances and the volume flow. For use in hazardous areas, special codes and regulations are also applicable and these are specified in a separate documentation.

Responsibility for the use of the measuring devices with regard to suitability, intended use and corrosion resistance of the used materials against the measured fluid lies solely with the operator.

This device is a Group 1, Class A device as specified within CISPR11:2009. It is intended for use in industrial environment. There may be potential difficulties in ensuring electromagnetic compatibility in other environments, due to conducted as well as radiated disturbances.

The manufacturer is not liable for any damage resulting from improper use or use for other than the intended purpose.

3.2 Mounting restrictions

3.2.1 General installation principles

There are no special installation requirements but you should note the following points:

- Support the weight of the meter.
- The meter can be supported on the sensor body.
- On larger meter sizes and hygienic connections, it is strongly recommended that the meter is not supported solely by the process pipework.
- No straight runs are required.
- The use of reducers and other fittings at flanges, including flexible hoses, is allowed but you should take care to avoid cavitation.
- Avoid extreme pipe size reductions.
- Meters are not affected by crosstalk and can be mounted in series or in parallel.
- Avoid mounting the meter at the highest point in the pipeline where air / gas can collect.

Mounting positions

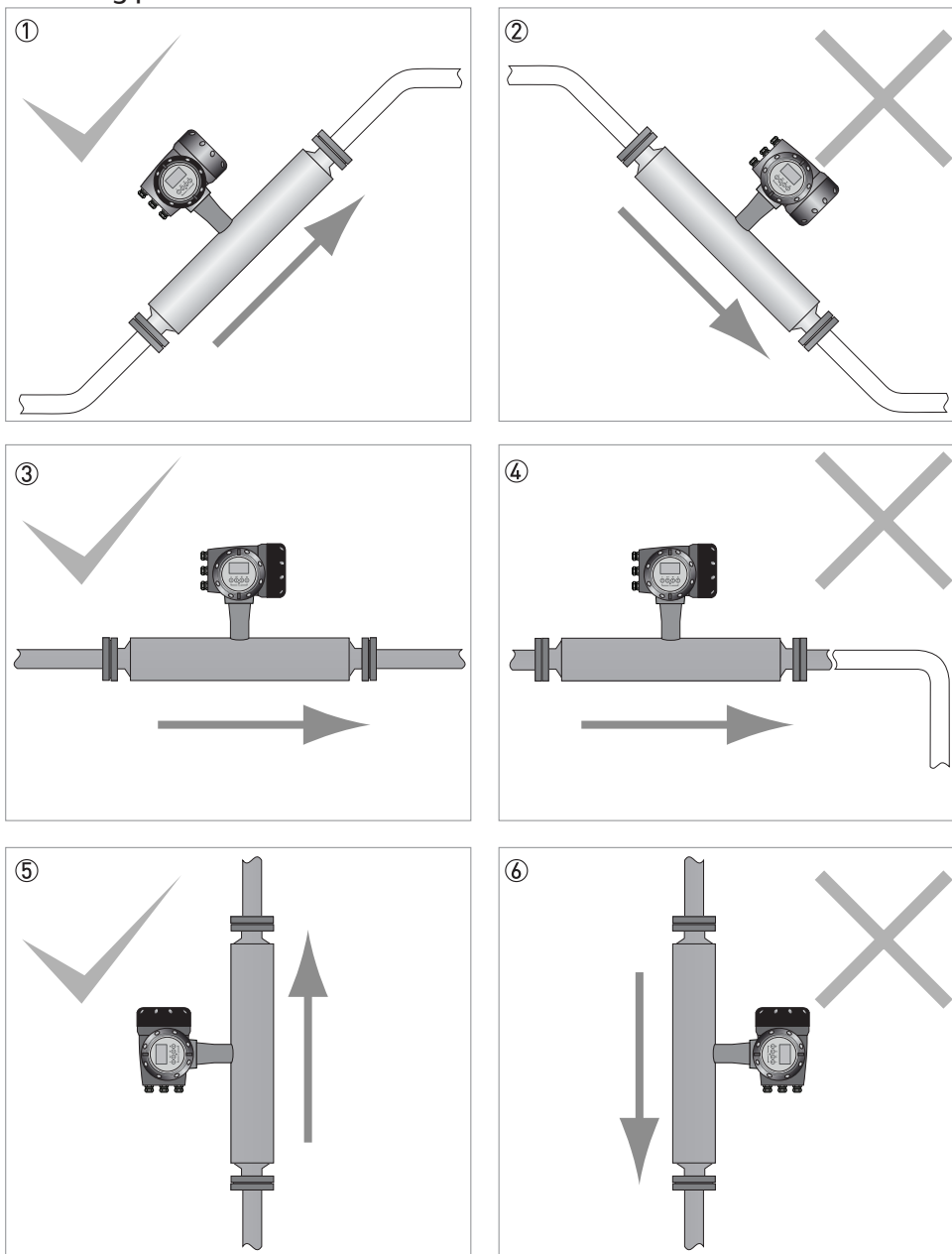

- 1 The meter can be mounted at an angle but it is recommended that the flow is uphill.
- 2 Avoid mounting the meter with the flow running downhill because it can cause siphoning. If the meter has to be mounted with the flow running downhill, install an orifice plate or control valve downstream of the meter to maintain backpressure.
- 3 Horizontal mounting with flow running left to right.
- 4 Avoid mounting meter with long vertical runs after the meter as it can cause cavitation. Where the installation includes a vertical run after the meter, install an orifice plate or control valve downstream to maintain backpressure.
- 5 The meter can be mounted vertically but it is recommended that the flow is uphill.
- 6 Avoid mounting the meter vertically with the flow running downhill. This can cause siphoning. If the meter has to be installed this way, install an orifice plate or control valve downstream to maintain backpressure.

Zero calibration

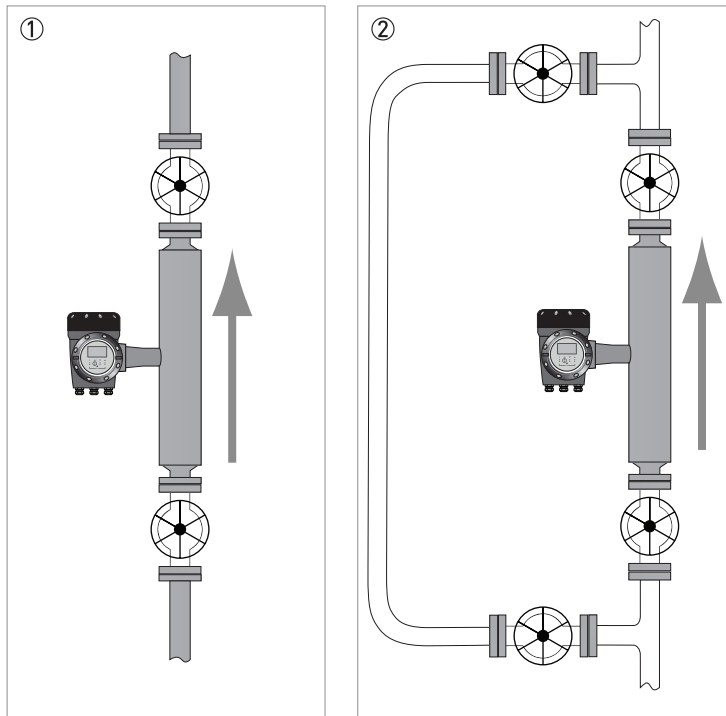

- 1 Where the meter has been installed vertically, install shut-off valves either side of the meter to assist with zero calibration.
- 2 If the process flow cannot be stopped, install a bypass section for zero calibration.

3.2.2 Sunshades

The meter **MUST** be protected from strong sunlight.

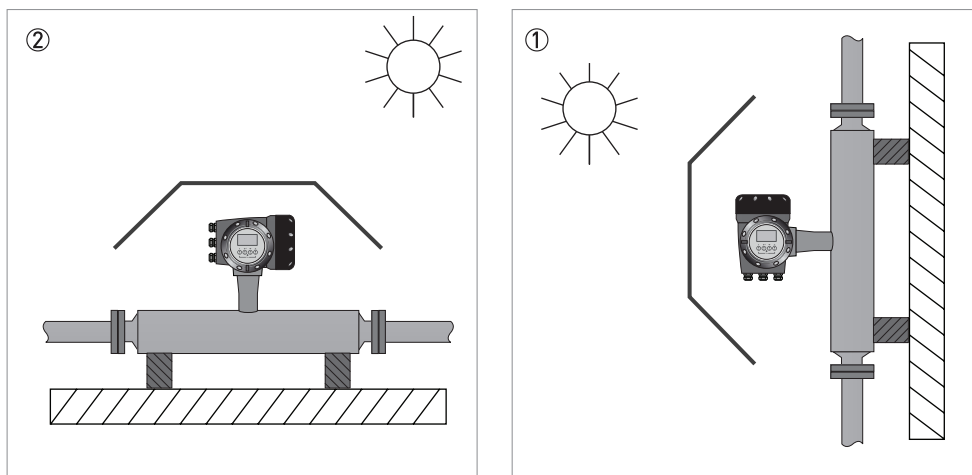

- 1 Horizontal installation
- 2 Vertical installation





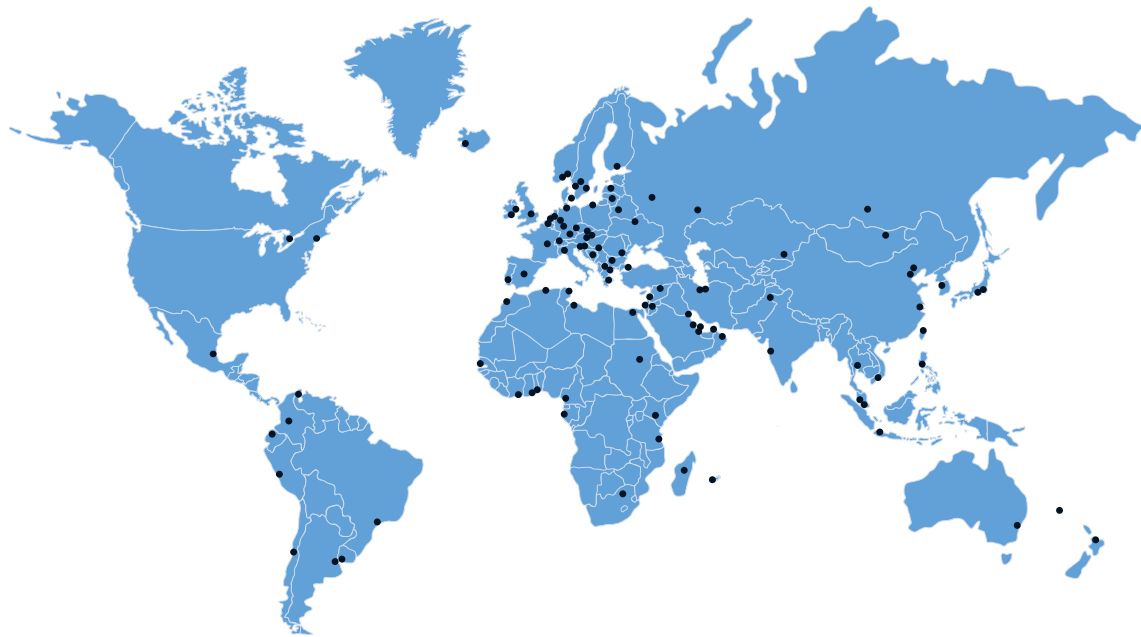

KROHNE – Process instrumentation and measurement solutions

- Flow
- Level
- Temperature
- Pressure
- Process Analysis
- Services

Head Office KROHNE Messtechnik GmbH
Ludwig-Krohne-Str. 5
47058Duisburg (Germany)
Tel.: +49203 301 0
Fax: +49203 301 10389
info@krohne.com

The current list of all KROHNE contacts and addresses can be found at:
www.krohne.com

KROHNE