



Senator S24W Technical Datasheet

24GHz Radar (FMCW) Level Transmitter for liquids in the water and waste water industry

- Proven Polypropylene (PP) Drop antenna, insensitive to condensation or deposits
- Narrow beam angle for a sharp focus on the medium
- Robust stainless steel design (IP68 / NEMA 4X/6)



Intercontrol

IJsselburcht 26
6825 BP Arnhem
Tel. +31 (0) 26 4425 204

info@intercontrol.eu

1 Product features	3
<hr/>	
1.1 The FMCW radar level transmitter for liquids in the water and wastewater industry...	3
1.2 Measuring principle	4
2 Technical data	5
<hr/>	
2.1 Technical data.....	5
2.2 Measuring accuracy	8
2.3 Minimum power supply voltage	9
2.4 Dimensions and weights	10
3 Installation	18
<hr/>	
3.1 Intended use	18
3.2 Pre-installation requirements	18
3.3 Installation	19
3.3.1 Pressure and temperature ranges.....	19
3.3.2 Recommended mounting position: tanks	20
3.3.3 Recommended mounting position.....	21
3.3.4 Mounting restrictions	22
3.3.5 Recommended mounting position: flow channels.....	24
3.3.6 Recommendations for pits and tanks made of non-conductive materials.....	25
4 Electrical connections	26
<hr/>	
4.1 Non-Ex devices.....	26
4.2 Networks	26
4.2.1 General information.....	26
4.2.2 Point-to-point connection	27
4.2.3 Multi-drop networks	28
5 Order information	29
<hr/>	
5.1 Accessories.....	29
6 Notes	30
<hr/>	

1.1 The FMCW radar level transmitter for liquids in the water and wastewater industry

This device is a non-contact radar level transmitter that uses FMCW technology. It measures distance, level and volume of liquids and pastes. It is a device that provides accurate readings in closed tanks, in the open air like rivers or dams, and can even measure volumetric flow rate.



- 1 PP Drop antenna. The PP Drop antenna has a small beam angle and is insensitive to condensation or deposits.
- 2 2-wire 24GHz FMCW radar level transmitter
- 3 10-metre electrical cable
- 4 Watertight stainless steel housing

Highlights

- Accuracy: $\pm 2\text{mm}$ / $\pm 0.08''$
- Measuring range: 20 m / 66 ft
- Small beam angle
- Process temperature: $-20\dots+80^\circ\text{C}$ / $-4\dots+176^\circ\text{F}$
- Process pressure: $-1\dots 3\text{ barg}$ / $-14.5\dots 43.5\text{ psig}$
- 2-wire 4...20mA (HART® 7)
- Maintenance-free concept
- Installation and operation made simple, safe and secure

Industries

- Water
- Wastewater

Applications

- Extraction, transport, storage and distribution of water from springs, rivers, lakes or the sea
- Rainwater basins
- Open-channel flow measurement
- Water, wastewater, sludge or other liquids in storage applications
- Wastewater pumping stations
- Floodwater alarm
- Liquid level of plastic tanks e.g. Intermediate Bulk Containers (IBC)

1.2 Measuring principle

A radar signal is emitted via an antenna, reflected from the product surface and received after a time t . The radar principle used is FMCW (Frequency Modulated Continuous Wave).

The FMCW-radar transmits a high frequency signal whose frequency increases linearly during the measurement phase (called the frequency sweep). The signal is emitted, reflected on the measuring surface and received with a time delay, t . Delay time, $t=2d/c$, where d is the distance to the product surface and c is the speed of light in the gas above the product.

For further signal processing the difference Δf is calculated from the actual transmitted frequency and the received frequency. The difference is directly proportional to the distance. A large frequency difference corresponds to a large distance and vice versa. The frequency difference Δf is transformed via a Fast Fourier Transform (FFT) into a frequency spectrum and then the distance is calculated from the spectrum. The level results from the difference between the tank height and the measured distance.

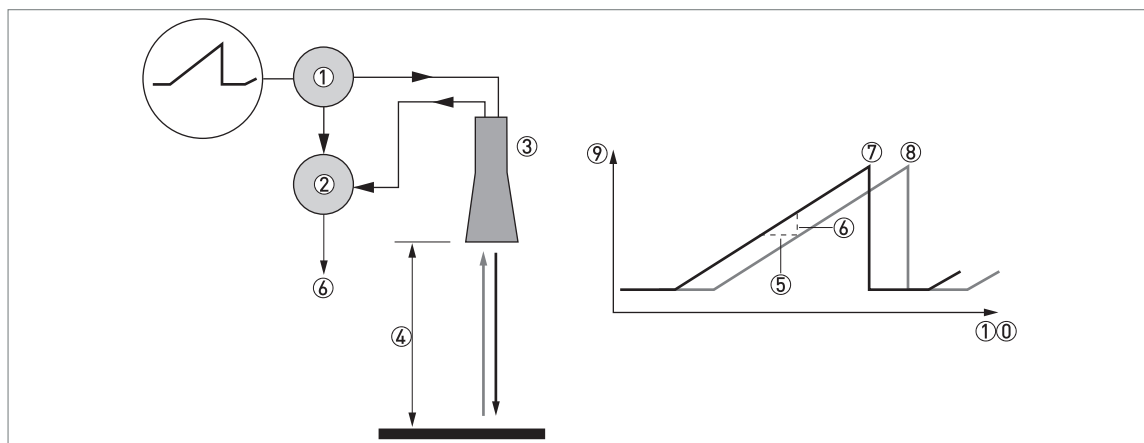

Figure 1-1: Measuring principle of FMCW radar

- 1 Transmitter
- 2 Mixer
- 3 Antenna
- 4 Distance to product surface, where change in frequency is proportional to distance
- 5 Differential time delay, Δt
- 6 Differential frequency, Δf
- 7 Frequency transmitted
- 8 Frequency received
- 9 Frequency
- 10 Time

2.1 Technical data

- *The following data is provided for general applications. If you require data that is more relevant to your specific application, please contact us or your local sales office.*
- *Additional information (certificates, special tools, software,...) and complete product documentation can be downloaded free of charge from the website.*

Measuring system

Measuring principle	2-wire loop-powered level transmitter; FMCW radar
Frequency range	K-band (24...26 GHz)
Max. radiated power (EIRP)	<-41.3dBm according to ETSI EN 302729(LPR)
Application range	Level measurement of liquids, pastes and slurries
Primary measured value	Distance and reflection
Secondary measured value	Level, volume, mass and flow rate

Design

Construction	The measurement system consists of a measuring sensor (antenna) and a signal converter
Max. measuring range (antenna)	20 m / 65.6 ft
Min. tank height	0.2 m / 8"
Recommended minimum blocking distance	0.8 m / 31.5"
Beam angle (antenna)	PP Drop, DN100 / 4": 8°
User interface	
User interface options	HART® Field Communicator. Download the Device Description (DD) file from the website. System or PC with PACTware™. Download the Device Type Manager (DTM) file from the website.

Measuring accuracy

Resolution	1mm/0.04"
Repeatability	±1mm/±0.04"
Accuracy	Standard: ±2mm/ ±0.08", when distance ≤ 10 m / 33 ft; ±0.02% of measured distance, when distance > 10 m / 33 ft. For more data, refer to <i>Measuring accuracy</i> on page 8.
Reference conditions acc. to EN 61298-1	
Temperature	+15...+25°C / +59...+77°F
Pressure	1013 mbara ±50 mbar / 14.69 psia ±0.73 psi
Relative air humidity(RH)	60% ±15%
Target	Metal plate in an anechoic chamber

Operating conditions

Temperature	
Ambient temperature	-20...+80°C/ -4...+176°F
Relative humidity(RH)	0...99%
Storage temperature	-40...+85°C/ -40...+185°F

Process connection temperature (higher temperature on request)	-40...+80°C/ -40...+176°F
Pressure	
Process pressure	Subject to the process connection used and the process connection temperature. For more data, refer to <i>Pressure and temperature ranges</i> on page 19.
Other conditions	
Dielectric constant (ϵ_r)	Direct mode: ≥ 2
Ingress protection	IEC 60529:IP66 / IP68 (continuous immersion at a gauge pressure of 0.2 barg for 2 weeks) NEMA 250: NEMA type 4X/6
Maximum rate of change	60 m/min / 196 ft/min

Installation conditions

Process connection size	The nominal diameter (DN) should be equal to or larger than the antenna diameter.
Process connection position	Make sure that there are not any obstructions directly below the process connection for the device. For more data, refer to <i>Installation</i> on page 18.
Dimensions and weights	For dimensions and weights data, refer to <i>Dimensions and weights</i> on page 10.

Materials

Housing	Standard: Stainless steel (1.4404/316L)
Wetted parts, including antenna	PP and stainless steel (1.4404/316L)
Process connection	Standard: Stainless steel (1.4404/316L) Option: PP
Cable gland	M20×1.5 with aluminium clamp

Process connections

Bottom of housing	G 3 A (ISO 228)
Top of housing	G 1 A (ISO 228)
Flange version	
EN 1092-1	DN80...100 in PN01 (max. 3 bar)
ASME B16.5	3...4" in Class 150 (max. 15 psig)
Other	Others on request

Electrical connections

Power supply	12...30V DC; min./max. value for an output of 21.5 mA at the terminals
Maximum current	21.5 mA
Current output load	$R_L [\Omega] \leq ((U_{ext} - 12V)/21.5mA)$. For more data, refer to <i>Minimum power supply voltage</i> on page 9.
Cable entry	M20×1.5
Cable entry capacity (terminal)	0.5...3.31 mm ² (AWG 20...12)

Input and output

Current output	
Output signal	Standard: 4...20 mA Options: 3.8...20.5 mA acc. to NAMUR NE 43; 4...20 mA (reversed); 3.8...20.5 mA (reversed) acc. to NAMUR NE 43
Output type	Passive

Resolution	±5 µA
Temperature drift	Typically 50 ppm/K
Error signal	High: 21.5mA; Low: 3.5 mA acc. to NAMUR NE 43
HART®	
Description	Digital signal transmitted with the current output signal (HART® protocol) 1
Version	7.4
Load	≥ 250 Ω
Digital temperature drift	Max. ±15 mm / 0.6" for the full temperature range
Multi-drop operation	Yes. Current output =4 mA. Enter Program mode to change the polling address (1...63).
Available drivers	FC475, AMS, PDM, FDT/DTM

Approvals and certification

CE	The device meets the essential requirements of the EU Directives. The manufacturer certifies successful testing of the product by applying the CE marking.
	For more data about the EU Directives and European Standards related to this device, refer to the EU Declaration of Conformity. You can download this document free of charge from the website.
Vibration resistance	EN 60068-2-6(5...8.51 Hz: 3 mm / 8.51...200 Hz:1g)
Shock resistance	EN 60068-2-27(25gshock ½ sinus: 6 ms)
Other standards and approvals	
Electromagnetic compatibility	EU: Electromagnetic Compatibility directive (EMC)
Radio approvals	EU: Radio Equipment directive (RED)
	FCC Rules: Part 15, Class B
	Industry Canada: RSS-211
Electrical safety	EU: Agrees with the safety part of the Low Voltage directive (LVD)
	USA and Canada: Agrees with NEC and CEC requirements for installation in ordinary locations
NAMUR	NAMUR NE 43 Standardization of the Signal Level for the Failure Information of Digital Transmitters
	NAMUR NE 53 Software and Hardware of Field Devices and Signal Processing Devices with Digital Electronics
	NAMUR NE 107 Self-Monitoring and Diagnosis of Field Devices

1 HART® is a registered trademark of the HART Communication Foundation

2.2 Measuring accuracy

Use these graphs to find the measuring accuracy for a given distance from the transmitter.

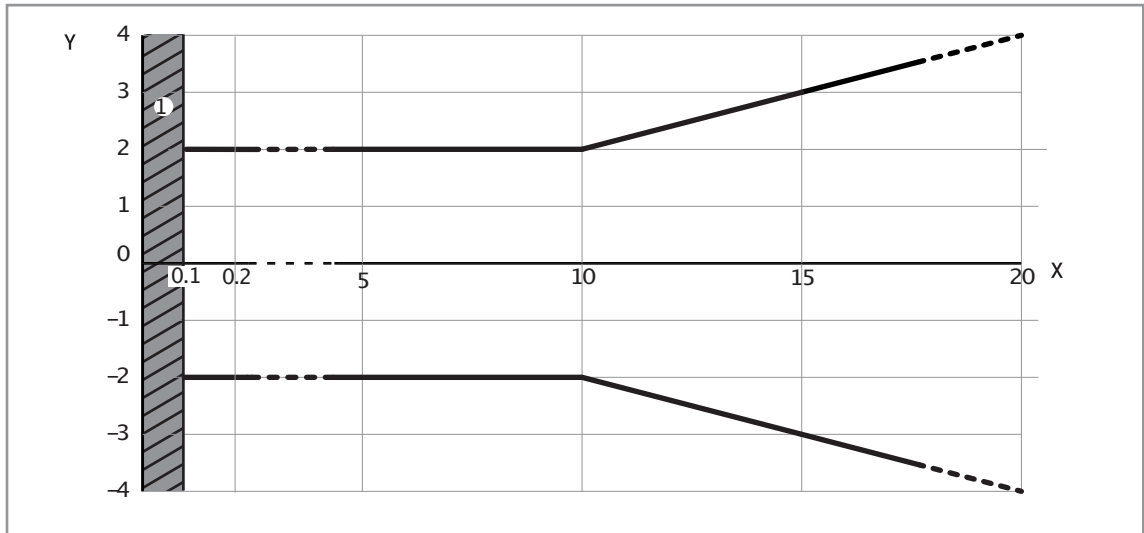

Figure 2-1: Measuring accuracy (graph of measuring accuracy in mm against measuring distance in m)

X: Measuring distance from the thread stop or flange facing of the process connection [m]

Y: Measuring accuracy [+yymm / -yymm]

1 Minimum recommended blocking distance = 0.8 m

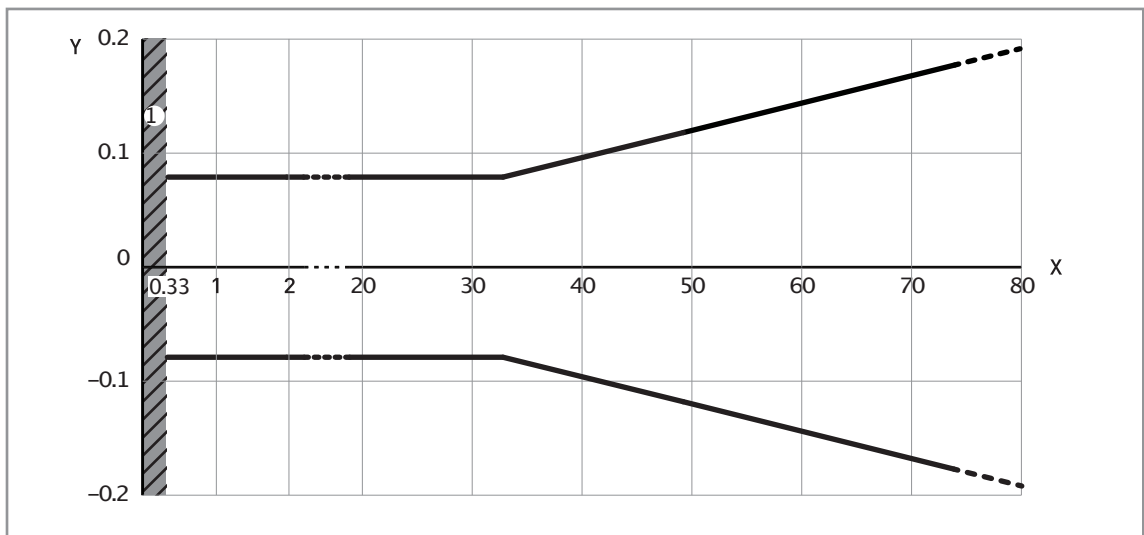

Figure 2-2: Measuring accuracy (graph of measuring accuracy in inches against measuring distance in ft)

X: Measuring distance from the thread stop or flange facing of the process connection [ft]

Y: Measuring accuracy [+yyinches / -yyinches]

1 Minimum recommended blocking distance = 31.5"

To calculate the accuracy at a given distance from the antenna, refer to Technical data on page 5 (measuring accuracy).

2.3 Minimum power supply voltage

Use this graph to find the minimum power supply voltage for a given current output load.

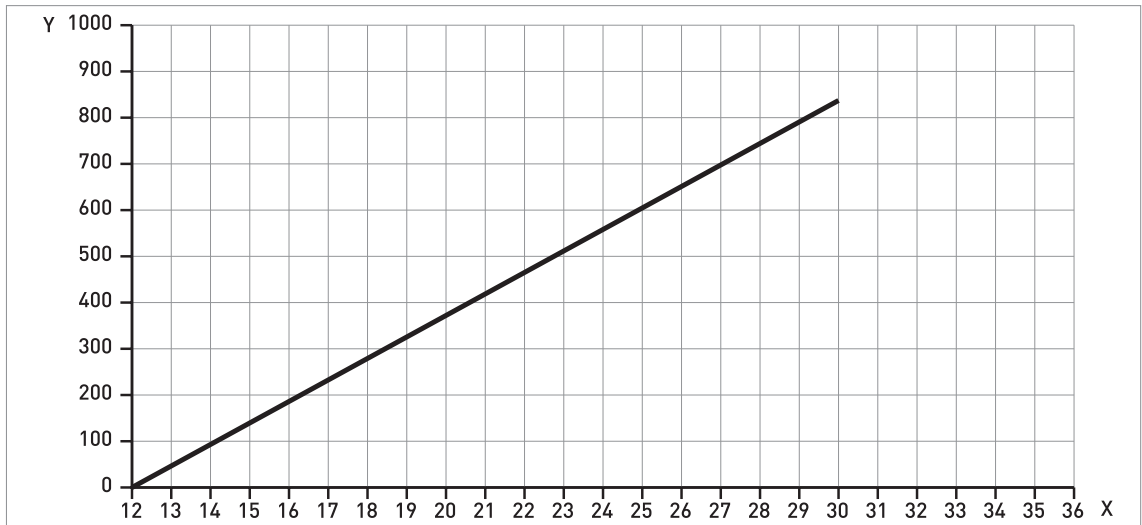

X: Power supply U [V DC]
 Y: Current outputload R_L [Ω]

2.4 Dimensions and weights

Device with top or bottom threaded connection

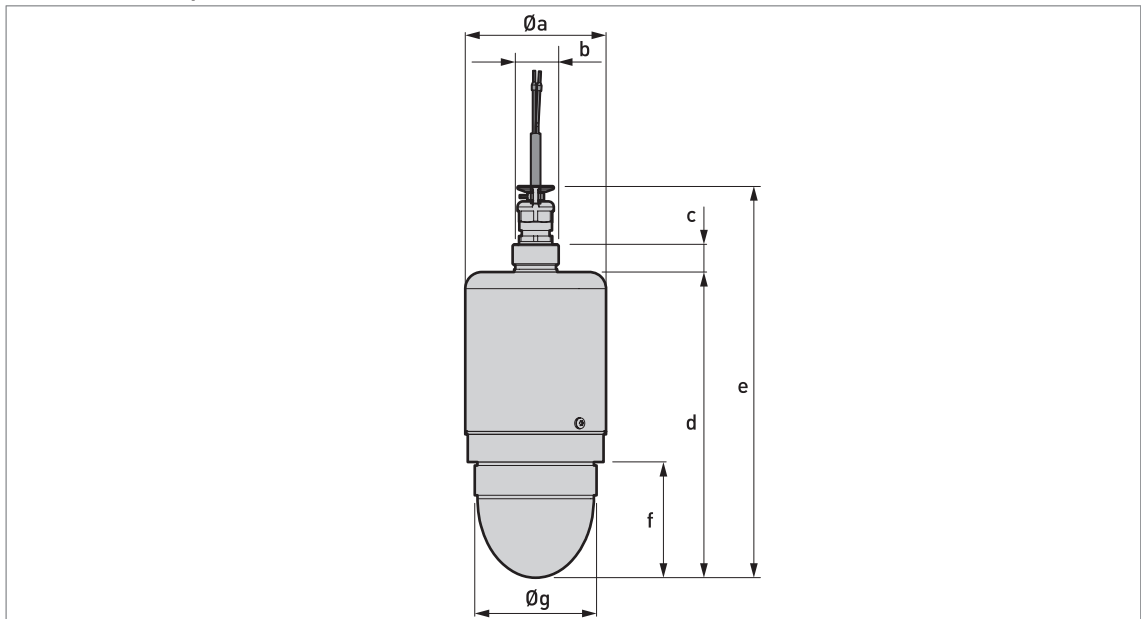

Figure 2-3: Device with top or bottom threaded connection

Dimensions [mm]						
Øa	b	c	d	e	f	Øg
101.6	G 1	20	220.7	282.7	83.5	G 3

Dimensions [inches]						
Øa	b	c	d	e	f	Øg
4.00	G 1	0.79	8.69	11.13	3.29	G 3

Device with top flange

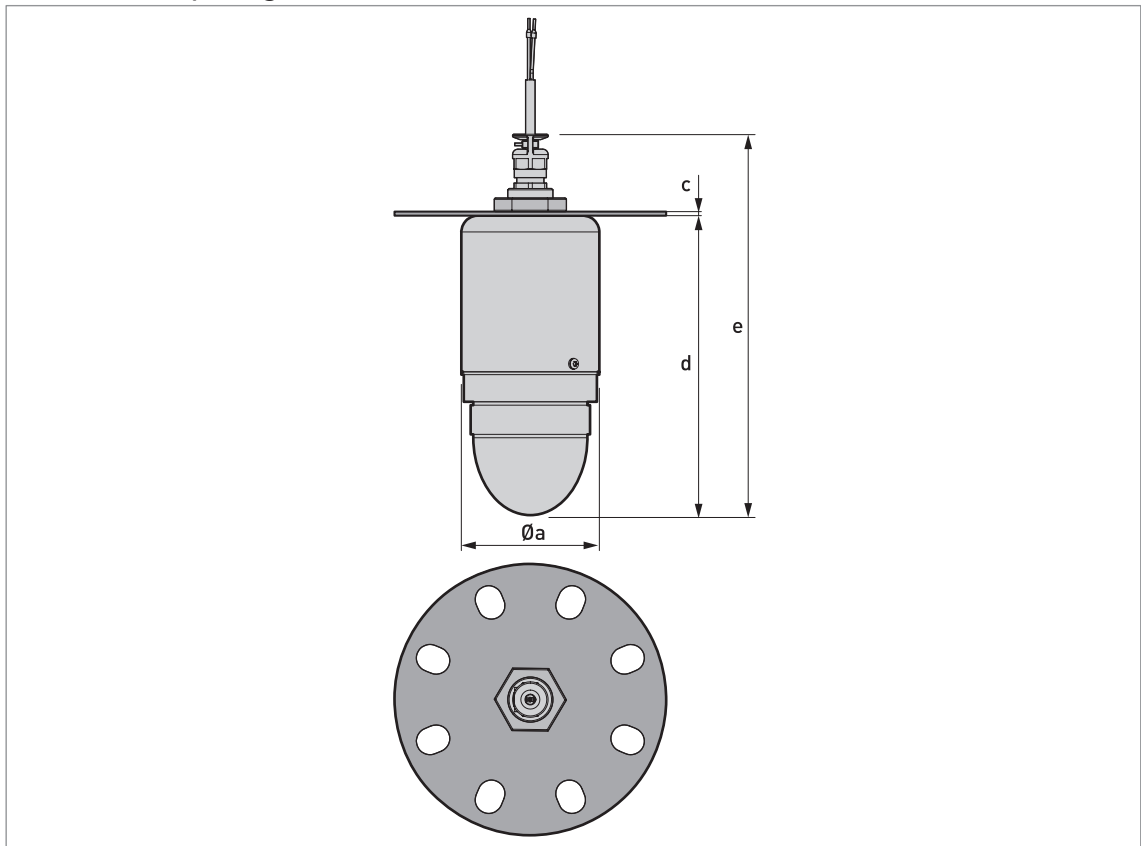

Figure 2-4: Device with top flange

Dimensions [mm]			
Øa	c	d	e
101.6	3	220.7	282.7

Dimensions [inches]			
Øa	c	d	e
4.00	0.12	8.69	11.13

Device with bottom flange

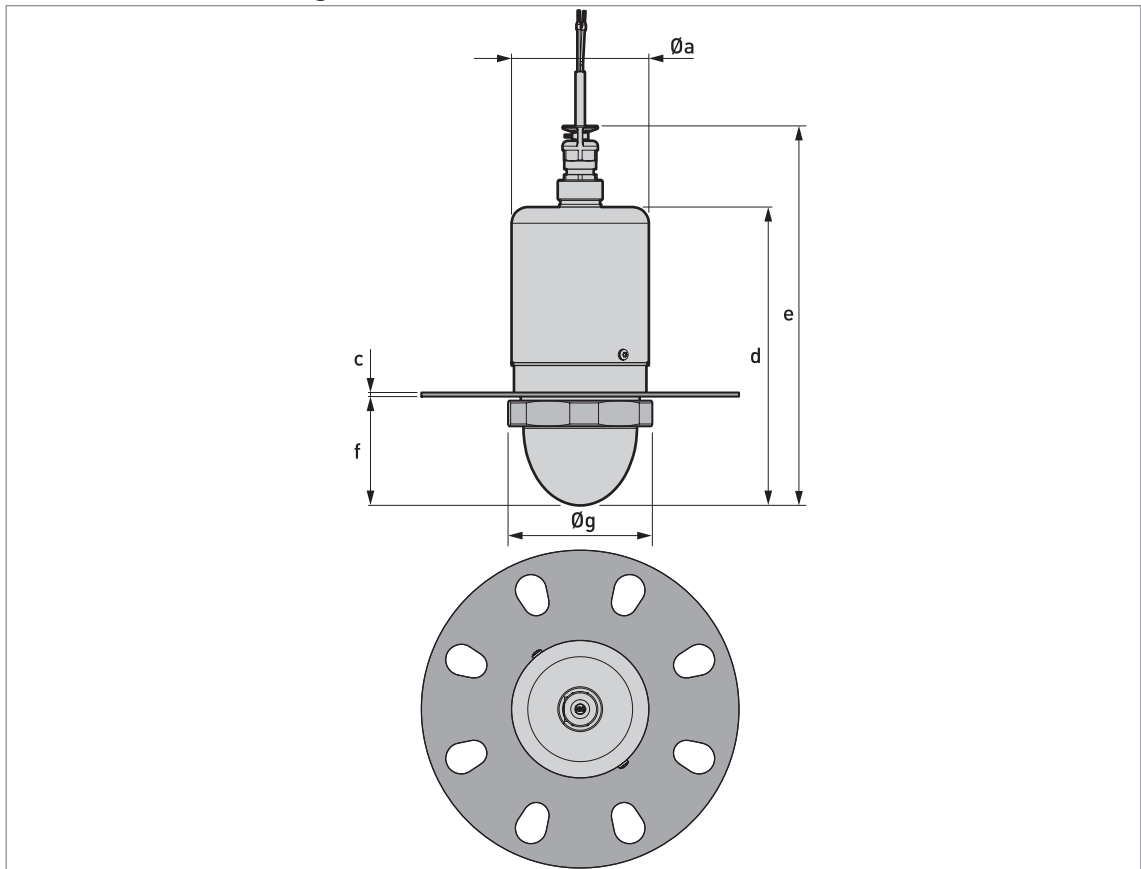

Figure 2-5: Device with bottom flange

Dimensions [mm]					
Øa	c	d	e	f	Øg
101.6	3	220.7	282.7	80.5	H105

Dimensions [inches]					
Øa	c	d	e	f	Øg
4.00	0.12	8.69	11.13	3.17	H105

Device with orientable collar

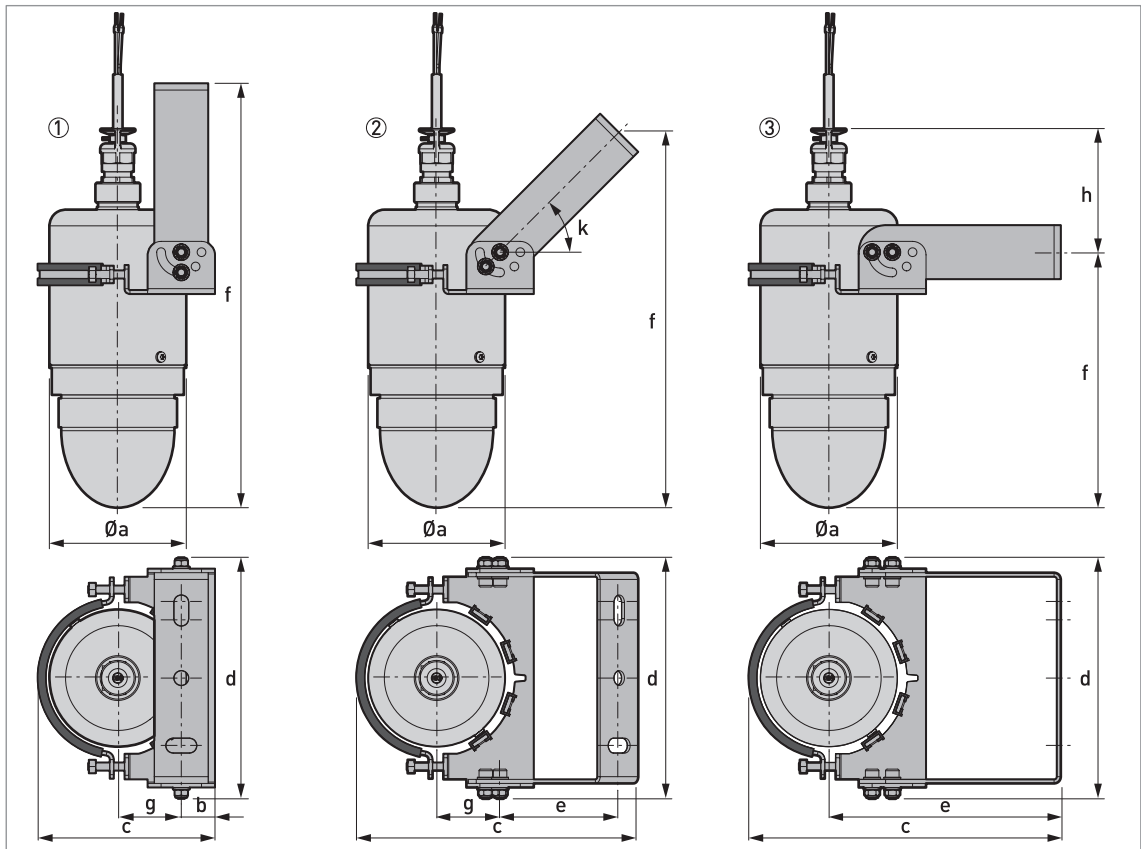

Figure 2-6: Device with orientable collar

- 1 Device with orientable collar and vertical fixed support
- 2 Device with orientable collar and fixed support at an angle of 45°
- 3 Device with orientable collar and horizontal fixed support

Make sure that there is sufficient clearance between the top of the cable gland and the ceiling to prevent damage to the electrical cable. The minimum clearance is 30 mm / 1.2" .

Fixed support position	Dimensions [mm]								
	Øa	b	c	d	e	f	g	h	k
Vertical	101.6	25	131.6	179.4	—	1	47.1	—	—
45°	101.6	—	209.1	179.4	88.4	1	47.1	—	45°
Horizontal	101.6	—	231.6	179.4	172.1	1	—	91.5	—

1 Make sure that there is sufficient clearance between the top of the cable gland and the ceiling to prevent damage to the electrical cable. The minimum clearance is 30 mm.

Fixed support position	Dimensions [inches]								
	Øa	b	c	d	e	f	g	h	k
Vertical	4.00	0.98	5.18	7.06	—	1	1.85	—	—
45°	4.00	—	8.23	7.06	3.48	1	1.85	—	45°
Horizontal	4.00	—	9.12	7.06	6.78	1	—	3.60	—

1 Make sure that there is sufficient clearance between the top of the cable gland and the ceiling to prevent damage to the electrical cable. The minimum clearance is 1.2".

Fixed support on the orientable collar

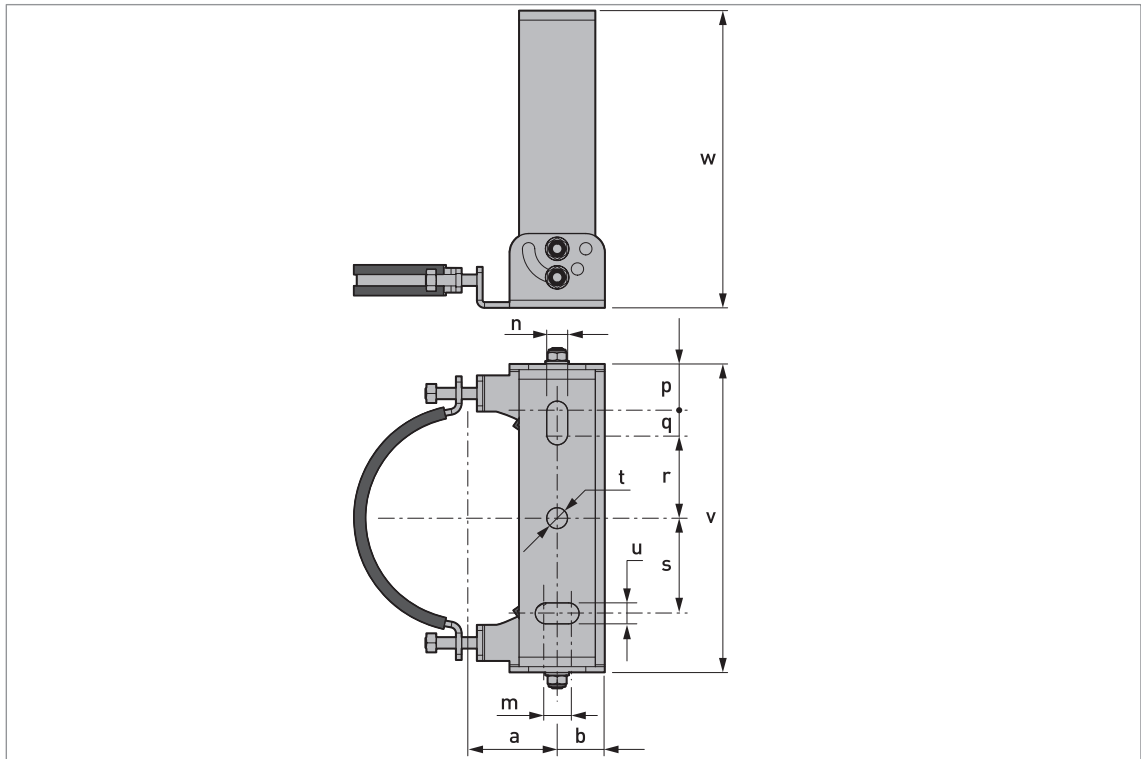

Figure 2-7: Fixed support on the orientable collar

Dimensions [mm]											
a	b	m	n	p	q	r	s	t	u	v	w
47	25	12	11	25	12	44	50	11	11	162	156

Dimensions [inches]											
a	b	m	n	p	q	r	s	t	u	v	w
1.85	0.98	0.47	0.43	0.98	0.47	1.73	1.97	0.43	0.43	6.38	6.14

Device with bracket

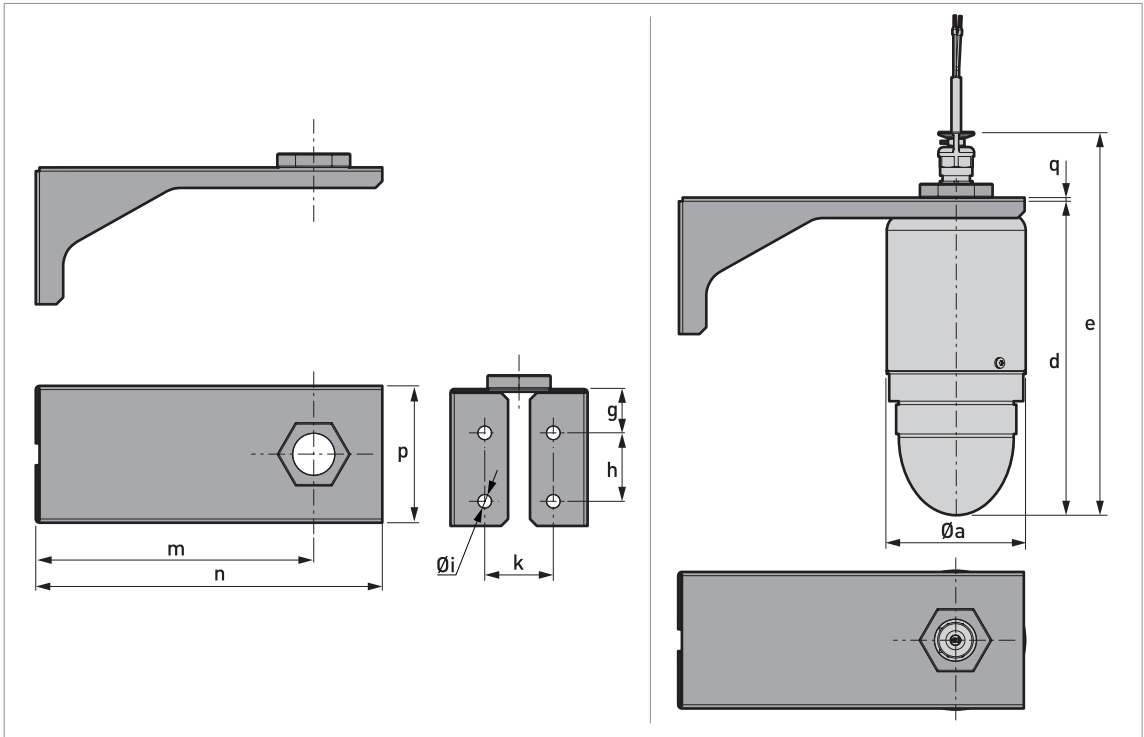

Figure 2-8: Device with bracket

Dimensions [mm]										
Øa	d	e	g	h	Øi	k	m	n	p	q
101.6	220.7	282.7	32	50	10	50	202.7	252.7	100	2

Dimensions [inches]										
Øa	d	e	g	h	Øi	k	m	n	p	q
4.00	8.69	11.13	1.26	1.97	0.39	1.97	7.98	9.95	3.94	0.08

Total weight

	Weights	
	[kg]	[lb]
Device with electrical cable (10 m / 32.8ft), without options	2.3	5.1

Weight, process connection options

	Weights	
	[kg]	[lb]

Low-pressure flange

Flange plate, DN100 / 4" 1	+1.44	+3.17
Flange plate, DN150 / 6" 1	+1.76	+3.88
Flange plate, DN200 / 8" 1	+2.22	+4.89

Other options

Orientable device collar with a support fitting	+0.78	+1.72
Wall support fitting (bracket)	+0.82	+1.81

1 Bolt hole positions and diameters agree with PN2.5...PN40 (EN 1092-1)andClass 150(ASME B16.5)

3.1 Intended use

Responsibility for the use of the measuring devices with regard to suitability, intended use and corrosion resistance of the used materials against the measured fluid lies solely with the operator.

The manufacturer is not liable for any damage resulting from improper use or use for other than the intended purpose.

This radar level transmitter measures distance, level, volume, flow and reflectivity of liquids, pastes and slurries.

It can be installed on tanks, reactors, open channels and open sea.

3.2 Pre-installation requirements

Obey the precautions that follow to make sure that the device is correctly installed.

- Heat sources (sunlight, adjacent system components etc.) can increase the internal temperature of the device and cause damage. Make sure that the internal temperature is not more than the maximum limit. The maximum permitted ambient temperature is +80°C/ +176°F. The maximum permitted surface temperature is +80°C/ +176°F.
- Do not subject the signal converter to heavy vibrations. The devices are tested for vibration and agree with EN 60068-2-6. If there is vibration, we recommend that you use the electrical cable clamp with a device hanger.

3.3 Installation

3.3.1 Pressure and temperature ranges

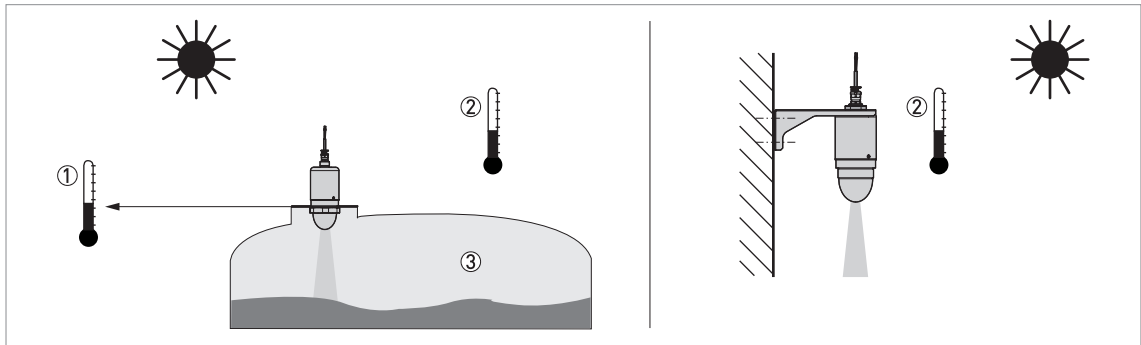

Figure 3-1: Pressure and temperature ranges

- 1 Temperature at the process connection
 Non-Ex devices: $-40\dots+80^{\circ}\text{C} / -40\dots+176^{\circ}\text{F}$
 Devices with Hazardous Location approvals: see supplementary instructions
- 2 Ambient temperature
 Non-Ex devices: $-20\dots+80^{\circ}\text{C} / -4\dots+176^{\circ}\text{F}$
 Devices with Hazardous Location approvals: see supplementary instructions
- 3 Process pressure
 max. 3 barg / 43.5 psig (threaded connection on the antenna)

Maximum process connection temperature and operating pressure

Antenna type	Options	Maximum process connection temperature		Maximum operating pressure	
		[°C]	[°F]	[barg]	[psig]
Drop, PP	G 3 threaded connection 1	+80	+176	3	43.5
Drop, PP	Other process connections	+80	+176	1 2	14.5 2

- 1 This process connection is on the antenna
- 2 Atmospheric pressure

3.3.2 Recommended mounting position: tanks

Follow these recommendations to make sure that the device measures correctly. They have an effect on the performance of the device.

We recommend that you prepare the installation when the tank is empty.

Nozzle position

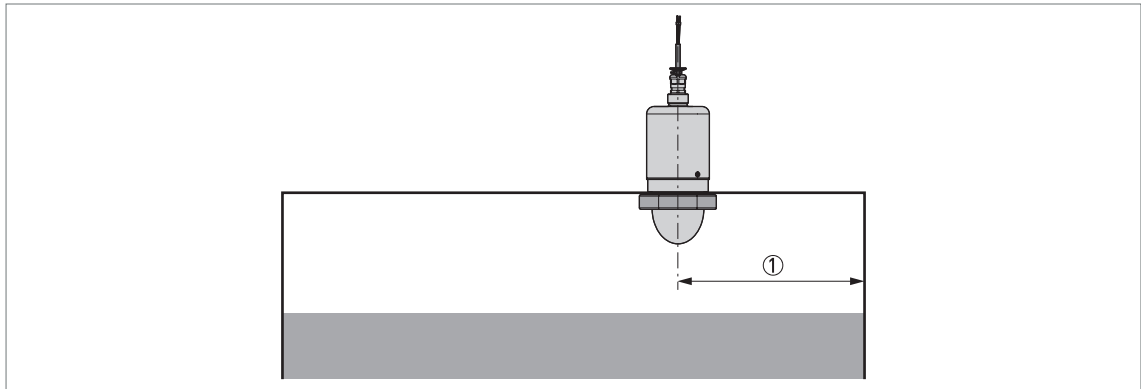

Figure 3-2: Nozzle position

- 1 Minimum distance of the nozzle or socket from the tank wall: 200mm / 7.9"

If there is a nozzle on the tank before installation, the nozzle must be a minimum of 200mm / 7.9" from the tank wall. The tank wall must be flat and there must not be obstacles adjacent to the nozzle or on the tank wall.

Other mounting positions

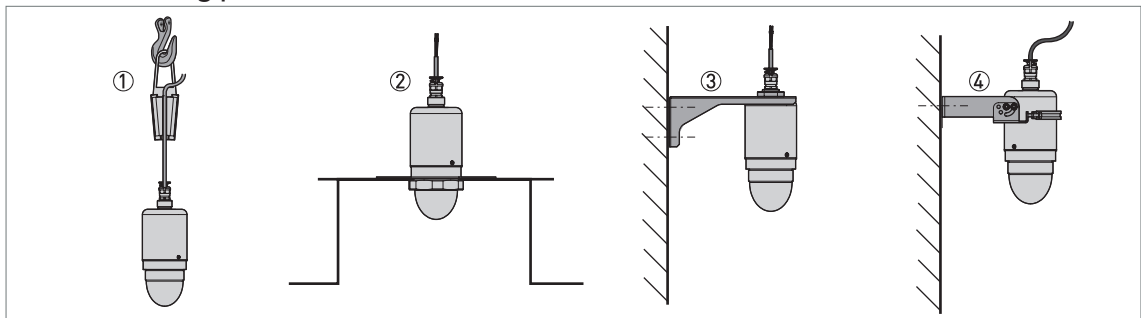

Figure 3-3: Other mounting positions

- 1 Suspended device (electrical cable clamp with device hanger)
- 2 Installation on a manhole. In this illustration, the device has the low-pressure flange option.
- 3 Device with a wall support (bracket)
- 4 Device attached to a wall with the orientable device collar

3.3.3 Recommended mounting position

Follow these recommendations to make sure that the device measures correctly. They have an effect on the performance of the device.

We recommend that you prepare the installation when the tank is empty.

Nozzle position

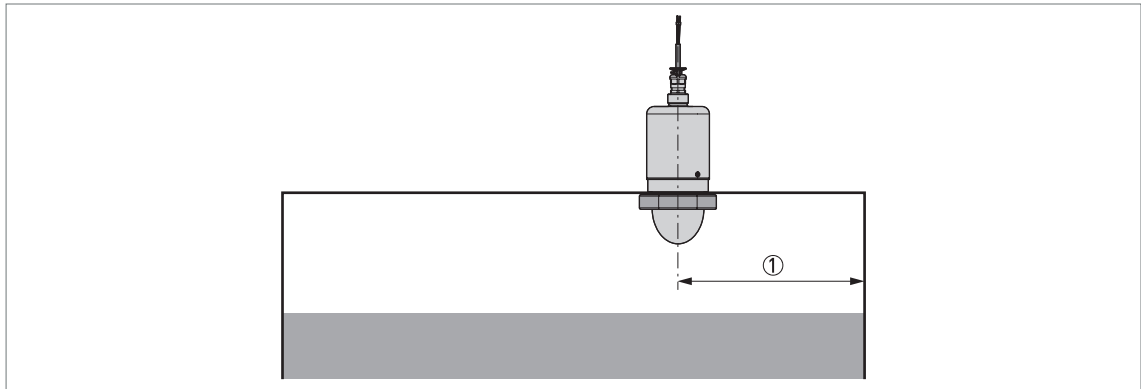

Figure 3-4: Nozzle position

- 1 Minimum distance of the nozzle or socket from the tank wall: 200mm / 7.9"

If there is a nozzle on the tank before installation, the nozzle must be a minimum of 200mm / 7.9" from the tank wall. The tank wall must be flat and there must not be obstacles adjacent to the nozzle or on the tank wall.

3.3.4 Mounting restrictions

*Do not install the device above objects in the tank (ladder, supports etc.) or pit. Objects in the tank or pit can cause interference signals. If there are interference signals, the device will not measure correctly.
If it is not possible to install the device on another part of the tank or pit, do an empty spectrum scan. For more data, refer to the handbook.*

If possible, do not install a nozzle on the tank centerline.

Equipment and obstacles

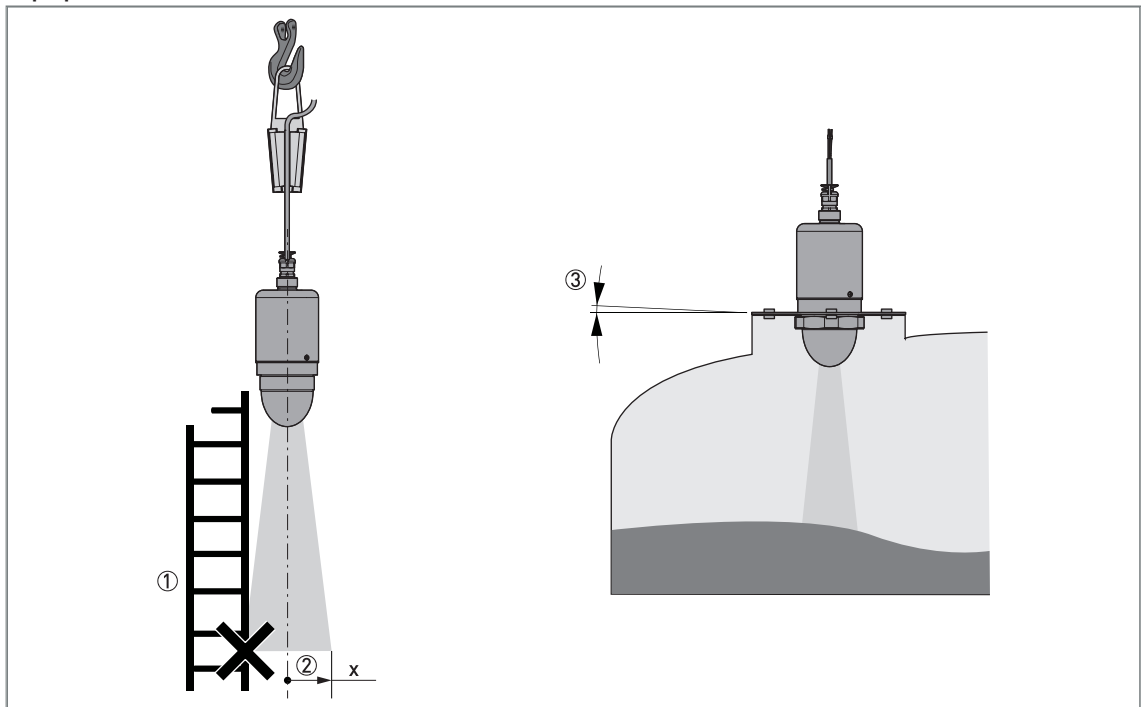

Figure 3-5: Equipment and obstacles: how to prevent measurement of interference signals

- 1 We recommend that you do an empty spectrum recording if there are too many obstacles in the radar beam (refer to the handbook).
- 2 Beam radius of the antenna: refer to the table below. The beam radius increases by increments of "x" mm for each metre of distance from the antenna.
- 3 Do not tilt the device more than 2°

Beam radius of the antenna

Antenna type	Beam angle	Beam radius, x	
		[mm/m]	[in/ft]
PP Drop, DN100(4")	8°	70	0.8

Product inlets

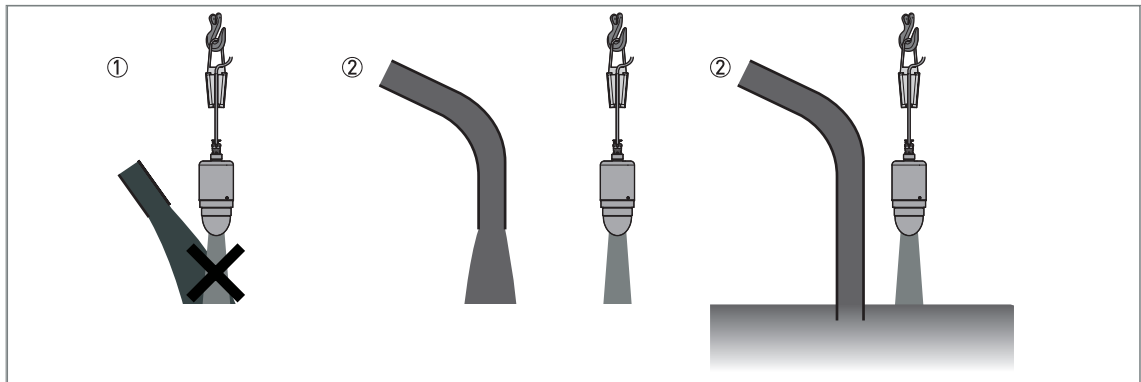

Figure 3-6: Product inlets

- 1 The device is too near to the product inlet.
- 2 The device is in the correct position.

Do not put the device near to the product inlet. If the product that enters the tank touches the antenna, the device will measure incorrectly. If the product fills the tank directly below the antenna, the device will also measure incorrectly.

3.3.5 Recommended mounting position: flow channels

Follow these recommendations to make sure that the device measures correctly. They have an effect on the performance of the device.

Do not use a device that uses an electrical cable clamp with a device hanger. Use a fixed, stable support.

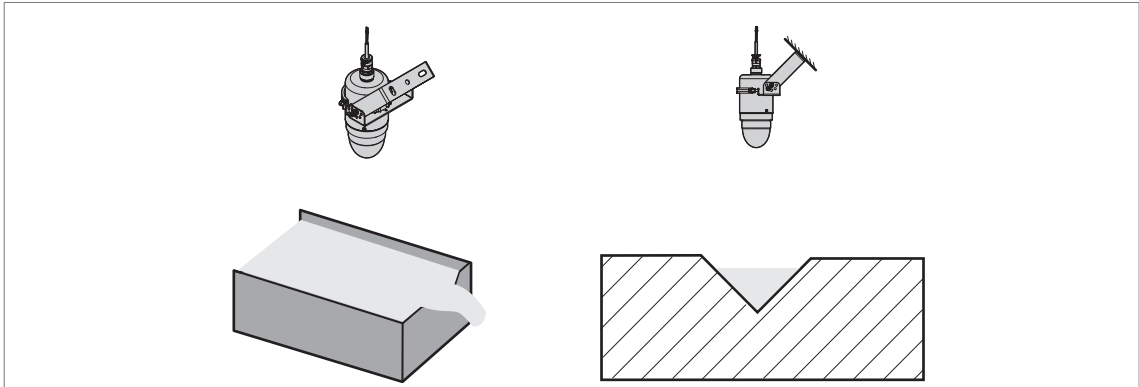

Figure 3-7: Recommended mounting position above a flow channel

If it is necessary to measure volumetric flow rate in the flow channel:

- Make sure that the flow channel agrees with one of the flow channel options available in the device DTM (PACTware).
- Go to menu **C3.1 Conversion Dry** in the device DTM (PACTware) and set the conversion table to "Volume Flow"
- Measure the dimensions of the flow channel and the position of the device above the flow channel.
- Enter the measured values in the DTM and complete the procedure.

Do the "A4.1 Standard Setup" procedure before you make a conversion table.

3.3.6 Recommendations for pits and tanks made of non-conductive materials

These instructions are for LPR equipment only.

Device installation on tanks made of a non-conductive material

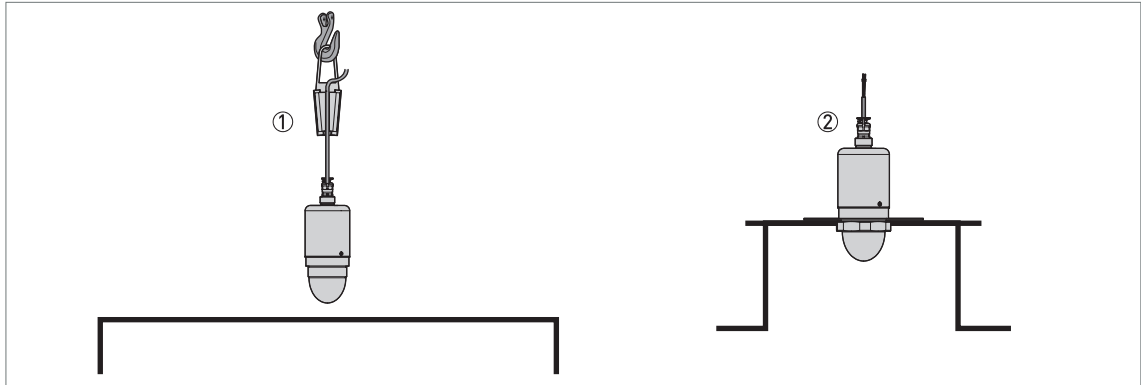

Figure 3-8: Device installation on tanks made of a non-conductive material

- 1 Device hung above a plastic tank
- 2 Device attached to a plastic tank

If the device cannot go in the tank and the tank is made of a non-conductive material (plastic etc.), you can attach a support to the top of the tank without a hole in the tank roof. We recommend that you put the antenna as near as possible to the top of the tank.

Do not hang and use this device above a plastic tank in bad weather conditions (rain etc.). Bad weather conditions can have an effect on the device performance.

We recommend that you do not hang and use this device above a plastic tank that has dust on it. Dust can have an effect on the device performance.

Open pits

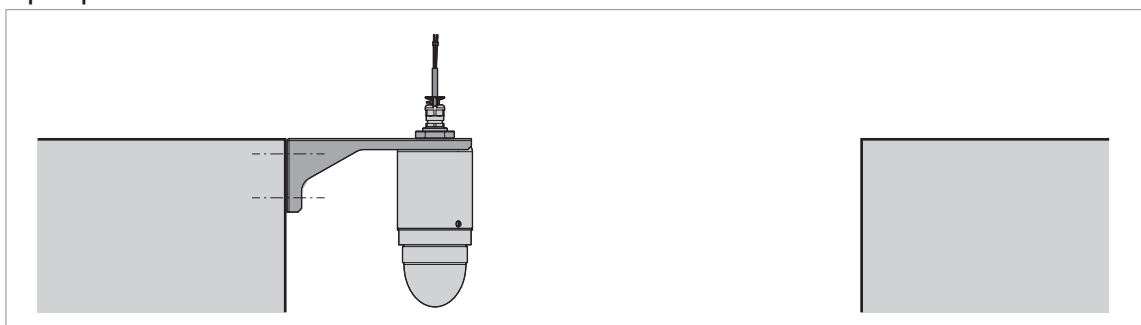

Figure 3-9: Open pits

If the device must measure the level of product in a pit, you can attach a support to the side of the pit or above the pit.

4.1 Non-Ex devices

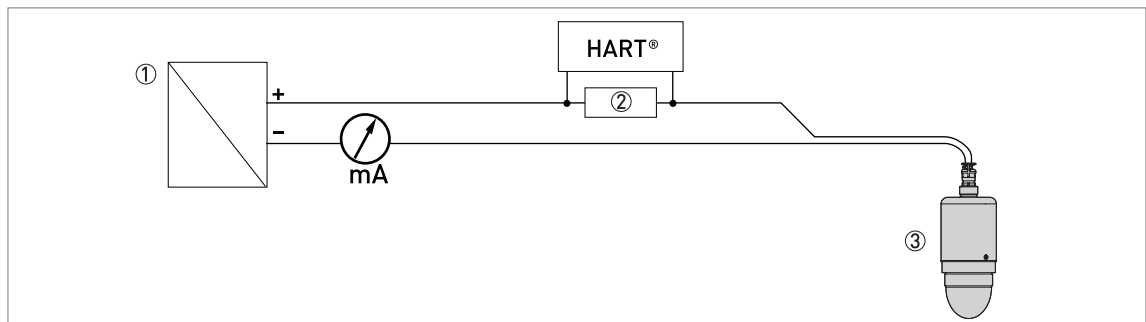

Figure 4-1:Electrical connections for non-Ex devices

- 1 Power supply
- 2 Resistor for HART® communication (typically 250ohms)
- 3 Device

Make sure that the brown wire (+) is connected to the positive terminal of the power supply and the blue wire (-) is connected to the negative terminal of the power supply. Connect the drain wire to ground.

Give the electrical cable protection from damage from wildlife (rats etc.), if it is necessary.

Electrical power to the output terminals energizes the device. The output terminal is also used for HART® communication.

4.2 Networks

4.2.1 General information

The device uses the HART® communication protocol. This protocol agrees with the HART® Communication Foundation standard. The device can be connected point-to-point. It can also have a polling address of 1 to 63 in a multi-drop network.

The device output is factory-set to communicate point-to-point. To change the communication mode from ~~point-to-point~~ to ~~multi-drop~~, use the DTM to change the polling address from "0" to a value from "1" to "63".

4.2.2 Point-to-point connection

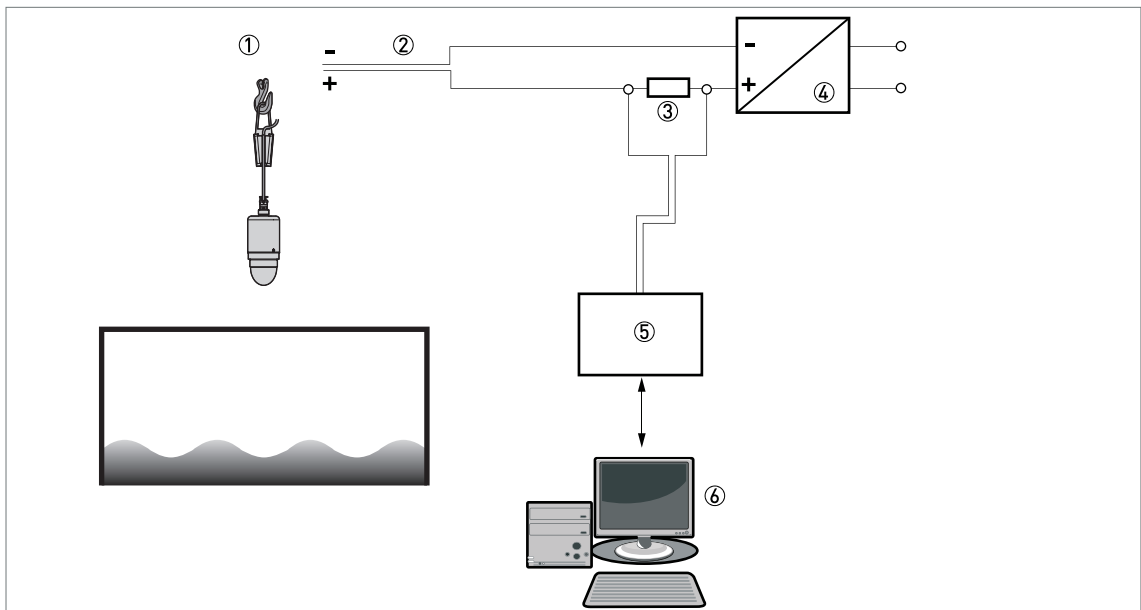

Figure 4-2: Point-to-point connection (non-Ex)

- 1 Address of the device (0 for point-to-point connection)
- 2 4...20 mA +HART®
- 3 Resistor for HART® communication (typically 250 ohms)
- 4 Power supply
- 5 HART® converter
- 6 HART® communications software

4.2.3 Multi-drop networks

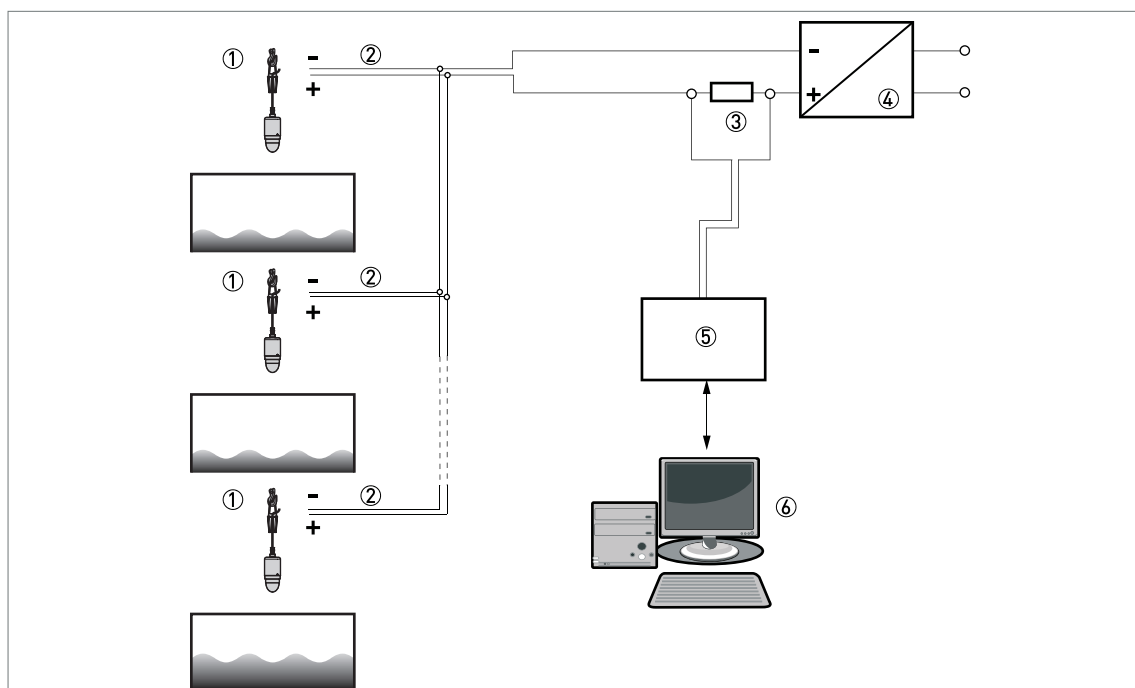

Figure 4-3: Multi-drop network (non-Ex)

- 1 Address of the device (each device must have a different address in multidrop networks)
- 2 4mA +HART®
- 3 Resistor for HART® communication (typically 250ohms)
- 4 Power supply
- 5 HART® converter
- 6 HART® communications software

5.1 Accessories

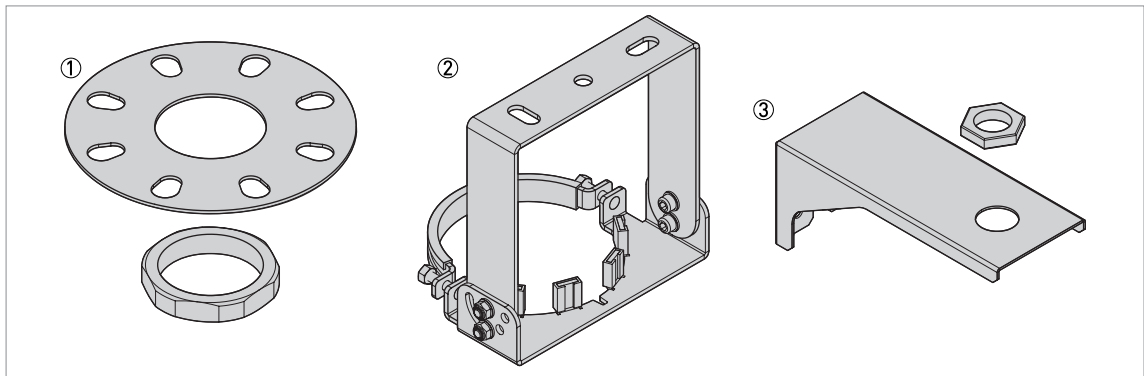

Figure 5-1:Accessories

- 1 Low-pressure flange with a jam nut (attaches the bottom of the device to a counter flange)
- 2 Orientable device collar with a support fitting (attaches the device to a ceiling or roof)
- 3 Wall support fitting (bracket)

Item	Description	Bolt hole positions and diameters EN 1092-1/ASME B16.5	Quantity
------	-------------	---	----------

316L low-pressure flange for G 3 threaded process connection

1	Low-pressure flange	DN100 PN2.5...PN40 / 4" 150lb	1
		DN150 PN2.5...PN40 / 6" 150lb	
		DN200 PN2.5...PN40 / 8" 150lb	

Other accessories

2	Orientable device collar with a support fitting	—	1
3	Wall support fitting (bracket)	—	1



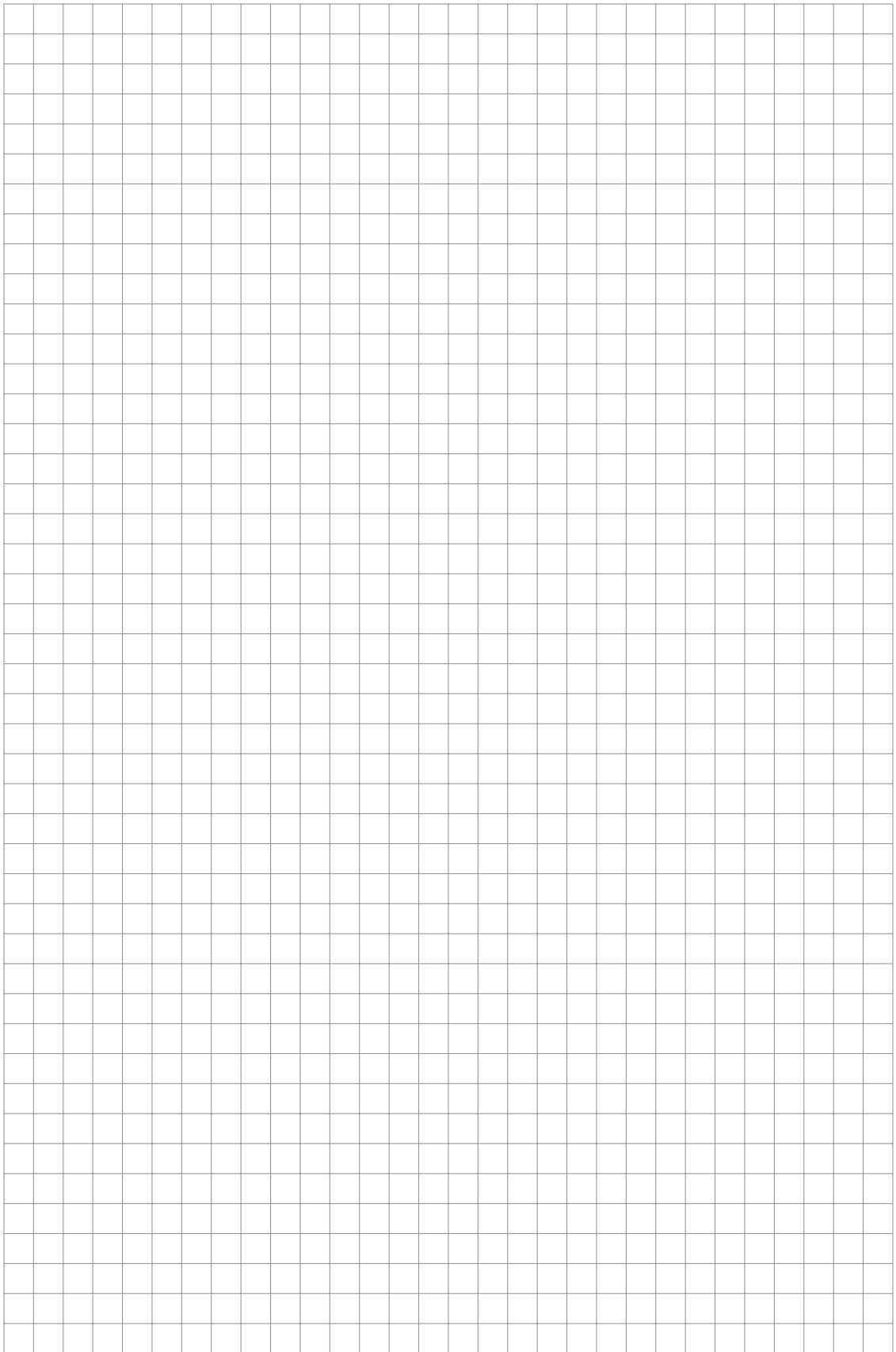

Hawk Measurement Systems (Head Office)

15 – 17 Maurice Court Nunawading VIC 3131, AUSTRALIA

Phone: +613 9873 4750

Fax: +613 9873 4538

info@hawkmeasurement.com

Hawk Measurement

5010 Gateway Drive, Medina, OH 44256, USA

Phone: +1888-429-5538

Phone: +1978-304-3000

Fax: +1978-304-1462

info@hawkmeasurement.com

For more information and global representatives: www.hawkmeasurement.com

