

Portable Flow Meter Series 2440

The Series 2440 provides air flow measurements in mass, volume, and velocity. The Series is designed for measuring ducts, pipes, stacks, vents, insitu calibrations, and airflow traverses. Models range from lab grade to industrial high heat. The Series 2440 includes:

- The highest repeatability, accuracy, and reliability available
- The fastest response to temperature and velocity changes in the industry
- Constant temperature thermal technology
- Excellent sensitivity to low velocities
- Insensitive to dirt and particulates in the flow stream
- Insensitive to installation angle
- 1,500 point data memory for recording traverses and other measurements
- Internal and exportable data logging
- Completely field configurable using the local user interface
- User-configurable low velocity cut-off, reference conditions, time constraints, and flow area
- Built-in flow totalizers and elapsed time
- Velocity-temperature mapping for wide ranging velocity and temperature
- Sensors do not overheat at zero flow by using a unique constant temperature control method and power limiting design
- Sensor lead-length independent circuitry

Kurz Instruments is dedicated to manufacturing and marketing the best thermal mass flow meters available and to support our customers in their efforts to improve their businesses.

Applications

- Industrial hygiene
- Survey tests
- HVAC supply and return ducts, grills, diffusers, and testing
- Flow balancing
- Clean rooms
- Fume hoods
- Combustion air velocity and flow calibration
- Duct, stack, and pipe velocity traverses
- Coal-fired power plant stacks
- Research and development
- General purpose air flow measurements



intercontrol

Intercontrol

IJsselburcht 26
6825 BP Arnhem
Tel. +31 (0) 26 4425 204

info@intercontrol.eu



SERIES FEATURES & SPECIFICATIONS

- **Easy-to-use interface**
Backlit display / keypad
2-lines of 16-characters each
- **Configuration upload/download**
- **User-configurable English or metric units for mass flow rate, mass velocity, and process temperature**
oC, oF, KGH, KGM, NCMH, NLPM, NMPS, PPH, PPM, SCFH, SCFM, SCMh, SFPM, SLPm, SMPS
- **Excellent resolution and noise rejection**
16-bit ADC, 50 Hz or 60 Hz
- **Time constant (configurable)**
0 to 600 seconds
- **User-selectable flow display (scrolling or static)**
- **All-metal aluminum display module**
- **Battery charger, 100-240VAC, 50/60Hz**
Nickel-Metal-Hydride 4.5 AH high-performance battery, 2.5 hour /full charge
- **Rugged carrying case**
- **European Union CE compliance**
EN 50081-1 for emissions, EN 50082-2 for immunity, EN 61000-4-5 for surges

OPTIONS

- **Digital outputs**
Modbus, RS-232C, or RS-485 serial port support; allows external/remote terminal configuration and data log access via a Windows computer
- **Analog 4-20mA outputs**
Configurable as velocity, flow rate, or temperature; 12-bit resolution, maximum loop resistance is 500 at 18 VDC, 800 at 24 VDC, 1400 at 36 VDC; NAMUR NE43 compliant
- **Hardware accessories**
Available hardware includes sensor support extensions, extension cables, batteries, battery chargers, and adapters



2441 FEATURES & SPECIFICATIONS

Laboratory-grade applications.

The Model 2441 Lab Grade Portable Flow Meter is excellent and well-suited for industrial hygiene and HVAC measurements.

- **13" sensor support length**
- **1/4" diameter sensor support**
- **Sensors temperature rated**
-40°F to 257°F (-40°C to 125°C)
- **Electronics operating temperature range**
-25°C to 65°C, noncondensing
- **Velocity time constant**
50 milliseconds for velocity changes at 6000 SFPM at a constant temperature and 300 milliseconds for temperature changes at a constant velocity of 6000 SFPM
- **Process temperature time constant**
8 seconds at a velocity of 6000 SFPM
- **Pressure rating up to 150 PSIG**
- **Velocity range 0 to 12,000 SFPM**
- **Temperature accuracy**
±(0.5% of reading + 1°C) for velocities above 100 SFPM
- **0.25% repeatability**



2442 FEATURES & SPECIFICATIONS

HVAC Applications.

The Model 2442 HVAC Portable Flow Meter is designed specifically for HVAC applications. The bendable gooseneck design and telescopic wand allows maximum flexibility in obtaining accurate traverse measurement in typically difficult location, such as ceilings, supply grates, and open areas.

- **Unique flexible "gooseneck" between the sensor element and sensor support**
- **Extendable four-segment telescopic wand**
- **47" sensor support length when fully extended**
- **1/4" diameter sensor support**
- **Sensors temperature rated**
-40°F to 257°F (-40°C to 125°C)
- **Electronics operating temperature range**
-25°C to 65°C, noncondensing
- **Velocity time constant**
50 milliseconds for velocity changes at 6000 SFPM at a constant temperature and 300 milliseconds for temperature changes at a constant velocity of 6000 SFPM
- **Process temperature time constant**
8 seconds at a velocity of 6000 SFPM
- **Pressure rating up to 150 PSIG**
- **Velocity range 0 to 12,000 SFPM**
- **Temperature accuracy**
±(0.5% of reading + 1°C) for velocities above 100 SFPM
- **0.25% repeatability**





2443 FEATURES & SPECIFICATIONS

Small-to-medium pipe and duct applications.

The Model 2443 Flow Meter is a small, rugged sensor designed for velocity and temperature traverses in small-to medium-sized pipes/ducts, such as in industrial ventilation systems.

- **13" sensor support length**
Probe shield can be reversed to extend support length up to 22"
- **3/8" diameter sensor support**
- **Sensors temperature rated**
-40°F to 392°F (-40°C to 200°C)
- **Electronics operating temperature range**
-25°C to 65°C, noncondensing
- **Velocity time constant**
1 second for velocity changes at 6000SFPM at a constant temperature and
1 second for temperature changes at a constant velocity of 6000SFPM
- **Process temperature time constant**
8 seconds at a velocity of 6000SFPM
- **Pressure rating up to 300PSIG**
- **Velocity range 0 to 12,000SFPM**
- **Temperature accuracy**
±(0.5% of reading + 1°C) for velocities above 100SFPM
- **0.25% repeatability**



2444 FEATURES & SPECIFICATIONS

Large pipe and duct applications.

The Model 2444 Heavy Industrial Portable Flow Meter provides the flexibility for a wide variety of field measurement applications because of multiple 16" sections that can connect up to 64.5" long.

- **Up to four extension support lengths**
16.5", 32.5", 48.5", 64.5"
- **3/4" diameter sensor support**
- **Sensors temperature rated**
-40°F to 392°F (-40°C to 200°C)
- **Electronics operating temperature range**
-25°C to 65°C, noncondensing
- **Velocity time constant**
1 second for velocity changes at 6000SFPM at a constant temperature and
1 second for temperature changes at a constant velocity of 6000SFPM
- **Process temperature time constant**
8 seconds at a velocity of 6000SFPM
- **Pressure rating up to 300PSIG**
- **Velocity range 0 to 12,000SFPM**
- **Temperature accuracy**
±(0.5% of reading + 1°C) for velocities above 100SFPM
- **0.25% repeatability**



2445 FEATURES & SPECIFICATIONS

High temperature applications.

The Model 2445 High-Temperature Portable Flow Meter is designed for very high temperatures (500°C) applications, such as coal-fired power plant stacks, and primary and secondary air ducts.

- **Five fixed support lengths**
24", 36", 48", 60", 72"
- **3/4" diameter sensor support**
- **Mineral-insulated sensor cable**
- **Sensors temperature rated**
-40°F to 932°F (-40°C to 500°C)
- **Handle (6") temperature rated up to 200°C**
- **Electronics operating temperature range**
-25°C to 65°C, noncondensing
- **Velocity time constant**
1 second for velocity changes at 6000SFPM at a constant temperature and
1 second for temperature changes at a constant velocity of 6000SFPM
- **Process temperature time constant**
8 seconds at a velocity of 6000SFPM
- **Pressure rating up to 300PSIG**
- **Velocity range 0 to 12,000SFPM**
- **Temperature accuracy**
±(0.5% of reading + 1°C) for velocities above 100SFPM
- **0.25% repeatability**



MODEL 2441 SENSOR

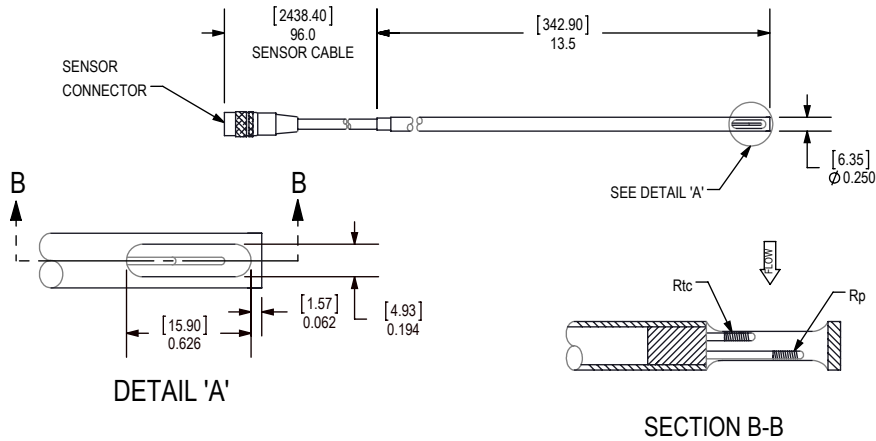

2441 PORTABLE EXTENSION

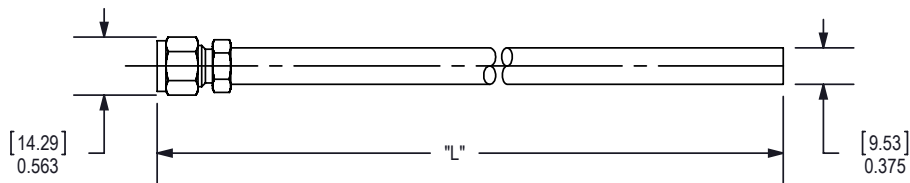

Dimensions are in inches [millimeters]

MODEL 2442 WAND & SENSOR

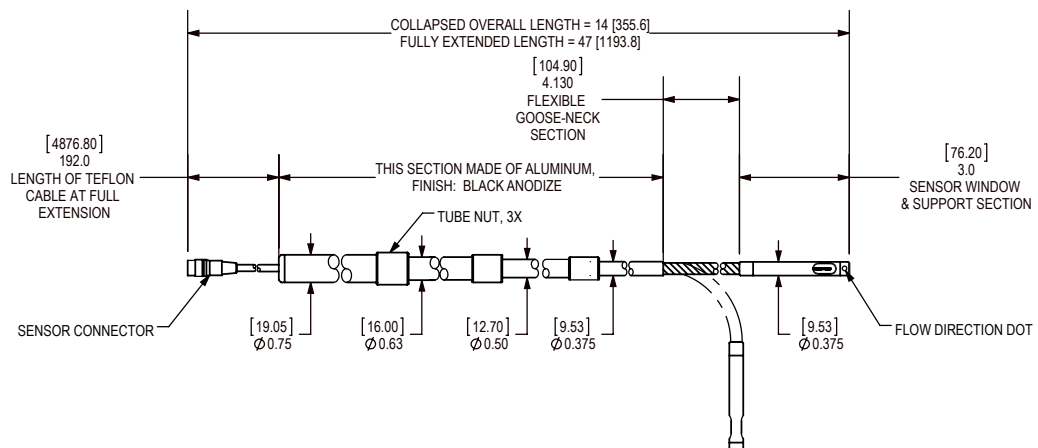

Dimensions are in inches [millimeters]



MODEL 2443 SENSOR

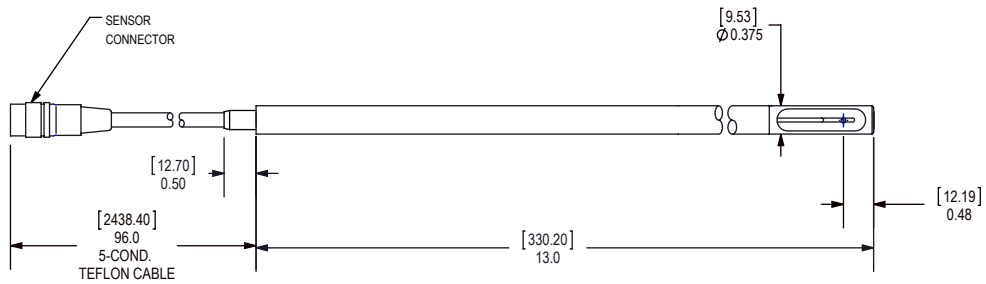

2443 PORTABLE EXTENSION

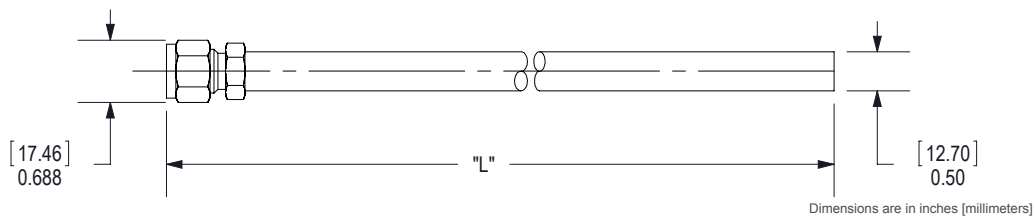

Dimensions are in inches [millimeters]

MODEL 2444 SENSOR

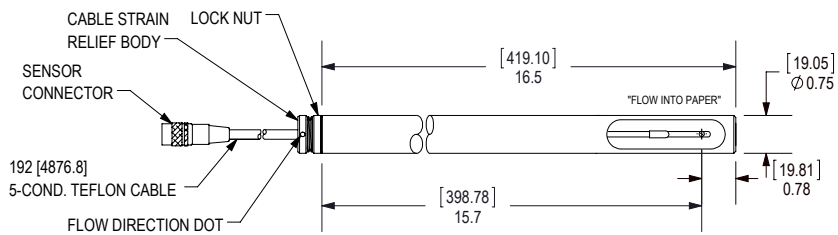

SENSOR SECTION

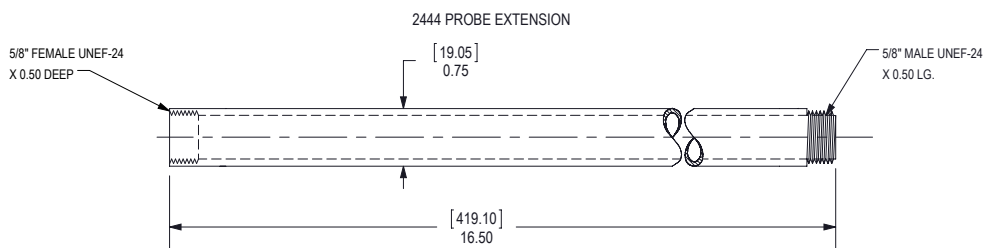

2444/2445 3/4" MNPT SENSOR SUPPORT PIPE EXTENSION (OPTIONAL)

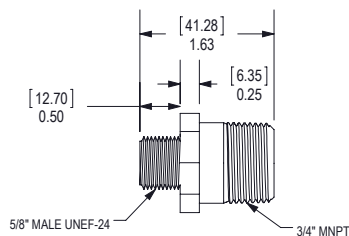

Dimensions are in inches [millimeters]



MODEL 2445 PROBE

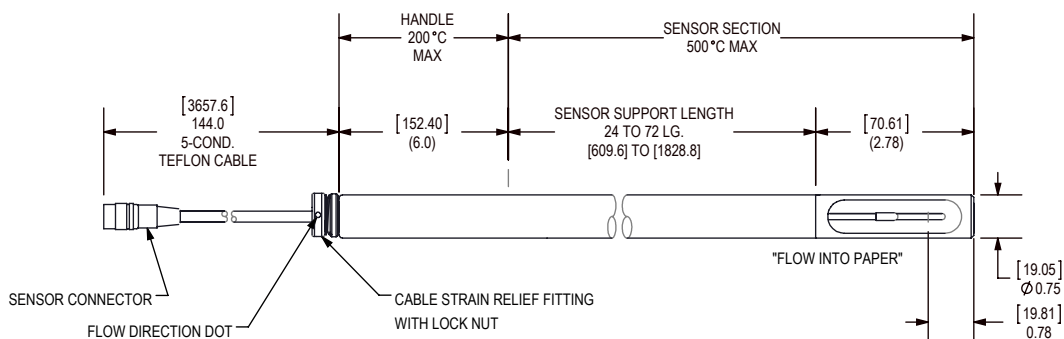

Dimensions are in inches [millimeters]

PORTABLE DISPLAY MODULE

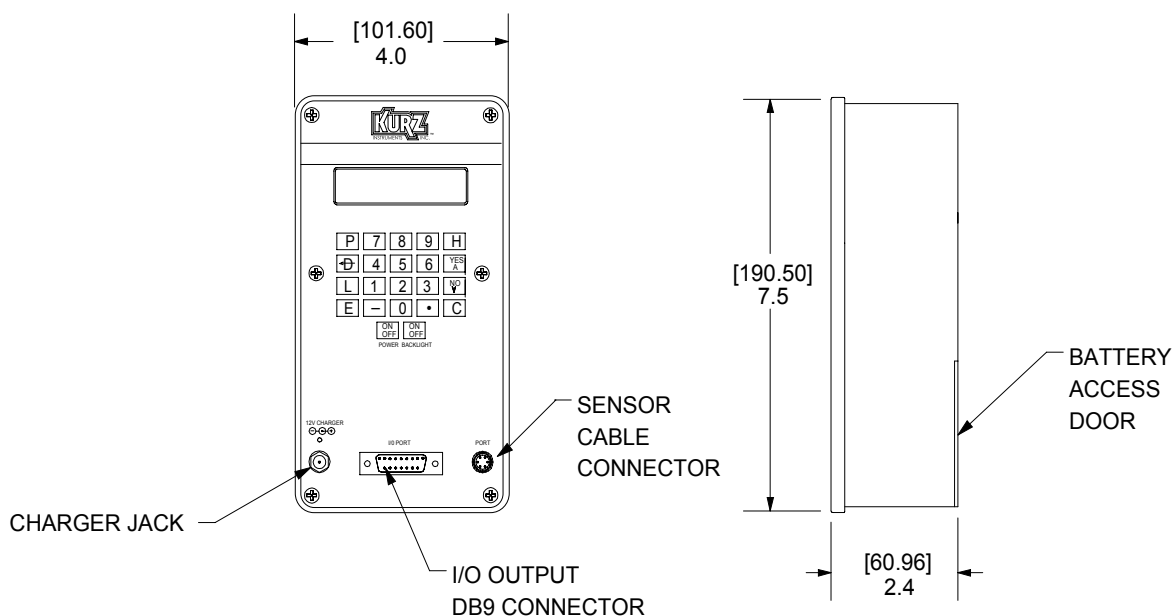

Dimensions are in inches [millimeters]



DISPLAY MODULE CARRYING CASE TYPE 1

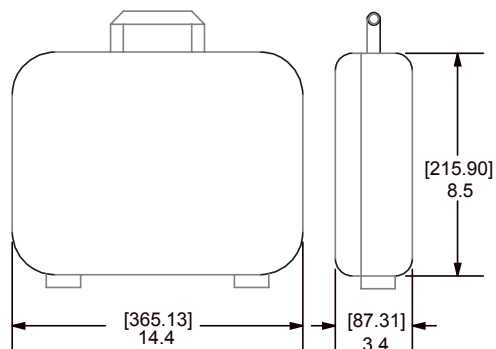

CARRYING CASE FOR MODELS WITH PROBE SUPPORT LENGTHS 24", 30", AND 36"

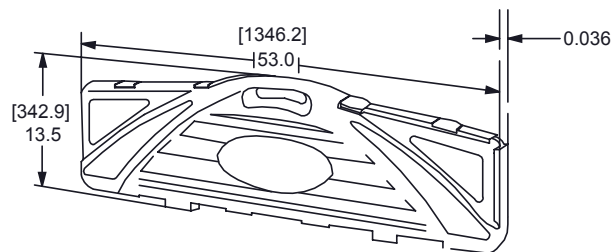

DISPLAY MODULE CARRYING CASE TYPE 2

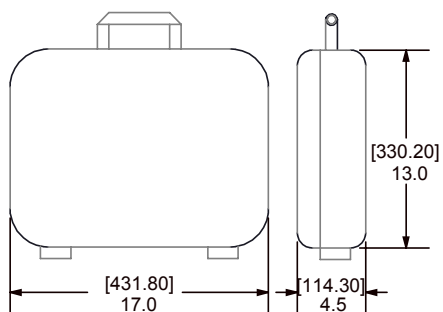

CARRYING CASE FOR MODELS WITH PROBE SUPPORT LENGTHS 48" TO 60"

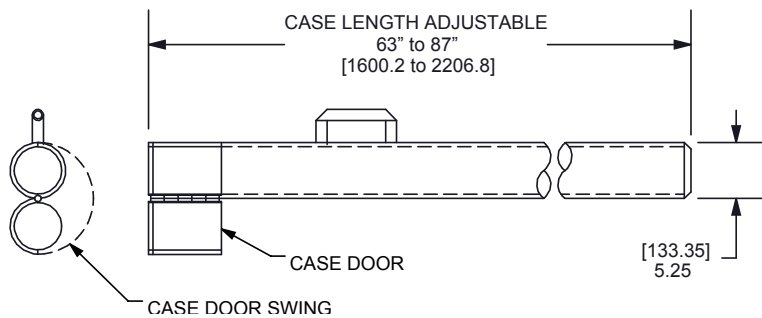



PROCESS TEMPERATURE & COMPENSATION

Kurz thermal flow meters determine the flow rate of gases by recognizing the mass density of molecules in the flow stream. The density of any gas is influenced by temperature changes. Specifying the temperature range experienced by a gas flow ensures repeatability and accuracy.

- **Standard Temperature Compensation (STC)** is used for small process temperature ranges, in this case from -15°C to 75°C , over a moderate velocity range.
- **Velocity Temperature Mapping (VTM)** is used when the process temperature and gas velocity vary widely. Multiple velocity calibrations are stored in the meter. VTM compensation is based on Air; specific gas correlations are required to ensure accuracy at high temperatures.

GAS VELOCITY CALIBRATION RANGE

The velocity data is taken in English units and Standard Temperature and Pressure (STP) reference conditions of 77°F and 14.69PSIA . If metric velocity units or a different STP is required, the user can easily change the STP reference, and select English or metric units using the display/ keypad. A sufficient number of calibration data points are taken to ensure accuracy over the entire range.

TIME RESPONSE

Time response is the time required to attain 63% (1 time constant) of the original reading after a step change in process temperature in constant velocity, or a step change in velocity at constant process temperature at an initial mass velocity of 6000SFPM .

SERIES 2440 ACCESSORIES

Series 2440 Accessories	
Part Number	Description
150001-01	Model 2441 sensor shield/extender
260102	RS-232 cable for upload/download, data transfer to PC, firmware updates
260106	Series 2440 I/O adapter cable
260108	Series 2440 AC power cord for charger
260110	Series 2440 vehicle charger adapter, 12VDC
260111-01	Series 2440 sensor extension cable, Teflon, 8-foot length
260111-02	Series 2440 sensor extension cable, Teflon, 16-foot length
260111-03	Series 2440 sensor extension cable, Teflon, 24-foot length
320029	Series 2440 battery, 4.5 Ah, six cell, NiMH
330046	Series 2440 AC charger, 100-240VAC, 50/60Hz
420334	Series 2440 I/O adapter module
451029	PC data logging program, CD-ROM, manual



2411 Garden Road • Monterey, CA 93940 | 800-424-7356 • 831-646-5911 | www.KurzInstruments.com

7540							01		
Parent number			F1	F2	F3	F4	F5	F6	F7
Parent Number	Model								
754010	2441	Laboratory-grade							
754020	2442	HVAC							
754030	2443	Small-to-medium pipes and ducts							
754040	2444	Large pipes and ducts							
754050	2445	High temperature							
F1	Model	Option	Sensor Type & Material						
2441	11		CD-AT; Glass-coated platinum wire over ceramic with epoxy sealant						
2442	11		CD-AT; Glass-coated platinum wire over ceramic with epoxy sealant						
2443	13		MC-MT; C-276 alloy with epoxy sealant						
2444	13		FD-MT; C-276 alloy						
2444	17		FD-MT; C-276 alloy with chromium nitride coating						
2445	13		FD-HHT; C-276 alloy						
2445	17		FD-HHT; C-276 alloy with chromium nitride coating						
F2	Model	Option	Sensor Support Length & Material						
2441	22		13"; 316L stainless steel						
2442	02		47" extended length; 316L stainless steel support chrome-plated flexible gooseneck anodized aluminum four-section telescopic wand						
2443	22		13"; 316L stainless steel						
2444	21		16.5" (base length); 316L stainless steel						
2444	22		32.5" (base length + one extension); 316L stainless steel						
2444	23		48.5" (base length + two extensions); 316L stainless steel						
2444	24		64.5" (base length + three extensions); 316L stainless steel						
2445	24		24"; 316L stainless steel						
2445	25		36"; 316L stainless steel						
2445	26		48"; 316L stainless steel						
2445	27		60"; 316L stainless steel						
2445	28		72"; 316L stainless steel						
F3	Model	Option	Sensor Cable Length & Material						
2441	11		8 feet; Teflon-insulated cable						
2442	12		12 feet; Teflon-insulated cable						
2443	11		8 feet; Teflon-insulated cable						
2444	13		16 feet; Teflon-insulated cable						
2445	12		12 feet; Teflon-insulated cable						
F4	Model	Option	Gas Velocity Calibration Data Range						
2441	18		12,000 SFPM						
2442	18		12,000 SFPM						
2443	18		12,000 SFPM						
2443	20		15,000 SFPM						
2444	18		12,000 SFPM						
2445	16		9,000 SFPM						
F5	Model	Option	Specialty Gas Velocity Calibration						
	All	01	Air						
F6	Model	Option	Gas Velocity Calibration Data Range						
2441	03		Standard temperature compensation (STC) for the process temperature range -15°C to 75°C; Accuracy: ±[3% of reading + 10 SFPM]						
2441	22		Velocity-temperature mapping (VTM) with two calibration data sets for the process temperature range -40°C to 125°C. Accuracy: ±[3% of reading + (10 SFPM + 0.25 SFPM/°C)], above or below 25°C.						
2442	03		Standard temperature compensation (STC) for the process temperature range -15°C to 75°C; Accuracy: ±[3% of reading + 10 SFPM]						
2442	22		Velocity-temperature mapping (VTM) with two calibration data sets for the process temperature range -40°C to 125°C. Accuracy: ±[3% of reading + (10 SFPM + 0.25 SFPM/°C)], above or below 25°C.						
2443	03		Standard temperature compensation (STC) for the process temperature range -15°C to 75°C; Accuracy: ±[3% of reading + 10 SFPM]; Velocity range 12,000 to 15,000 SFPM.						
2443	24		Velocity-temperature mapping (VTM) with three calibration data sets for the process temperature range -40°C to 200°C. Feature 4, Option 18 only. Accuracy: ±[3% of reading + (20 SFPM + 0.25 SFPM/°C)], above or below 25°C.						
2444	24		Velocity-temperature mapping (VTM) with three calibration data sets for the process temperature range -40°C to 200°C. Accuracy: ±[3% of reading + (20 SFPM + 0.25 SFPM/°C)], above or below 25°C.						
2445	26		Velocity-temperature mapping (VTM) with four calibration data sets for the process temperature range -40°C to 500°C. Accuracy: ±[3% of reading + (30 SFPM + 0.25 SFPM/°C)], above or below 25°C.						
F7	I/O Adapter & Digital Outputs								
Choose one option from each category; all models.									
Option	I/O Adapter (first digit)								
0	No I/O adapter								
1	I/O adapter includes a 2-foot cable with a multipin adapter, a 6-foot RS-232 cable with DB9F connectors to support connection between the I/O adapter and a Windows computer, and a connector used for firmware upgrades. I/O adapter supports RS-495 or RS-232 and two 4-20mA isolated, loop-powered outputs.								
Option	Digital Outputs (second digit)								
0	No digital outputs								
2	Two 4-20mA loop-powered outputs, AC/DC optically isolated.								

