

KROHNE



OPTIFLUX 2000 Technical Datasheet

Electromagnetic flow sensor

- For all water and wastewater applications
- Wide range of approvals for potable water
- Robust, fully welded construction



KTW



WRAS
Water Regulations Advisory Scheme

The documentation is only complete when used in combination with the relevant documentation for the signal converter.

 **intercontrol**

© KROHNE 10/2019-4000086807-TD OPTIFLUX 2000R11 en

Intercontrol

IJsselburcht 26
6825 BP Arnhem
Tel. +31 (0) 26 4425 204

info@intercontrol.eu

1	Product features	3
1.1	Reliable solution for the water and wastewater industry	3
1.2	Options	5
1.3	Measuring principle	7
2	Technical data	8
2.1	Technical data	8
2.2	Legal metrology	15
2.2.1	OIML R49	15
2.2.2	MID Annex III (MI-001)	17
2.3	Measuring accuracy	19
2.4	Pressure derating	20
2.5	Vacuum load	22
2.6	Dimensions and weights	23
3	Installation	27
3.1	Intended use	27
3.2	General notes on installation	27
3.2.1	Vibrations	27
3.2.2	Magnetic field	27
3.3	Installation conditions	28
3.3.1	Inlet and outlet	28
3.3.2	Bends in 2 or 3 dimensions	28
3.3.3	T-section	29
3.3.4	Bends	29
3.3.5	Open discharge	30
3.3.6	Flange deviation	30
3.3.7	Pump	30
3.3.8	Control valve	31
3.3.9	Air venting and vacuum forces	31
3.3.10	Mounting position	32
3.4	Installation in a metering pit and subsurface applications	33
3.5	Mounting	34
3.5.1	Torques and pressures	34
4	Electrical connections	38
4.1	Safety instructions	38
4.2	Grounding	38
4.3	Virtual reference for IFC 300(C, W and F version)	40
4.4	Connection diagrams	40
5	Notes	41

1.1 Reliable solution for the water and wastewater industry

The **OPTIFLUX 2000** is designed to meet the demands for all water and waste water applications including groundwater, potable water, waste water, sludge and sewage, industry water and salt water.

The OPTIFLUX 2000 has a field proven and unsurpassed lifetime. This is assured by the fully welded construction, full bore pipe, absence of moving parts and wear resistant liner materials. The sensor has the widest diameter range available in the market: from DN25 up to DN3000.



- 1 Robust fully welded construction
- 2 Diameter range: DN25...DN3000
- 3 PP, PO and hard rubber liners

Highlights

- Rugged liners suitable for any water and wastewater application
- Proven and unsurpassed lifetime, huge installed base
- Tamper proof, fully welded construction, also available in customer specific constructions
- Drinking water approvals including KTW, KIWA, ACS, DVGW, NSF, WRAS
- Suitable for subsoil installation and constant flooding (IP 68)
- Bi-directional flow metering
- Compliant with requirements for custody transfer (MID MI-001, OIML R49, ISO 4064, EN 14154)
- Standard in house wet calibration of sensors up to diameter DN3000
- Easy installation and commissioning
- No grounding rings with virtual reference option on IFC 300
- In-situ verification with OPTICHECK
- Extensive diagnostic capabilities
- Maintenance-free

Industries

- Water
- Wastewater
- Pulp & Paper
- Minerals & Mining
- Iron, Steel & Metals
- Power

Applications

- Water abstraction
- Water purification and desalination
- Drinking water distribution networks
- Revenue metering or billing
- Leakage detection
- Irrigation
- Industry water
- Cooling water
- Wastewater
- Sewage and sludge
- Sea water

1.2 Options

The reliable solution for the water and wastewater industry



From standard to customized

For easy ordering the standard range of the OPTIFLUX 2000 covers all popular sizes, flange materials and connections (ASME, EN, JIS, AWWA). But KROHNE does not stop here. Our extensive engineering department is dedicated to provide solutions for all specifications not covered by our standard range. Requests for special sizes, flange connections, pressure ratings, building lengths, and materials, will always get a serious review. Whenever possible we will engineer a flow meter that fits your application.



Easy installation

Fitting the OPTIFLUX 2000 is easy with the flanged design and standard ISO insertion lengths. To further ease the operation, the OPTIFLUX 2000 can be installed without filters and straighteners. Even grounding rings are not required with the patented "Virtual Reference" option on the IFC 300 converter.



IP 68

Installation in measurement chambers subject to (constant) flooding is possible with the IP68 rated version. The chambers can even be completely surpassed if the IP68 version is combined with our special subsoil coating, allowing the OPTIFLUX 2000 to be installed directly in the ground.



Custody transfer

In combination with the IFC 300 converter the OPTIFLUX 2000 is suitable for custody transfer applications. It meets the requirements of OIML R49 and can be verified according to Annex MI-001 of the Measuring Instruments Directive (MID)

All water meters for legal metrology purposes in Europe require certification under the MID. The EC type examination certificate for the OPTIFLUX 2300 is valid for the compact and the remote version and applies for forward and reverse flow.

1.3 Measuring principle

An electrically conductive fluid flows inside an electrically insulated pipe through a magnetic field. This magnetic field is generated by a current, flowing through a pair of field coils.

Inside of the fluid, a voltage U is generated:

$$U = v * k * B * D$$

in which:

v = mean flow velocity

k = factor correcting for geometry

B = magnetic field strength

D = inner diameter of flowmeter

The signal voltage U is picked off by electrodes and is proportional to the mean flow velocity v and thus the flow rate Q . A signal converter is used to amplify the signal voltage, filter it and convert it into signals for totalizing, recording and output processing.

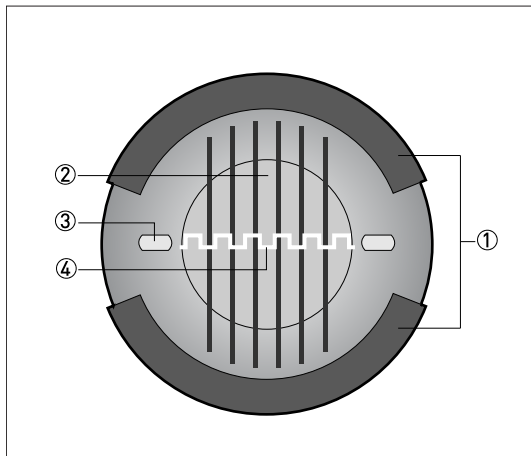

Figure 1-1: Measuring principle

- 1 Field coils
- 2 Magneticfield
- 3 Electrodes
- 4 Induced voltage (proportional to flow velocity)

2.1 Technical data

- *The following data is provided for general applications. If you require data that is more relevant to your specific application, please contact us or your local sales office.*
- *Additional information (certificates, special tools, software,...) and complete product documentation can be downloaded free of charge from the website (Downloadcenter).*

Measuring system

Measuring principle	Faraday's law of induction
Application range	Electrically conductive fluids
Measured value	
Primary measured value	Flow velocity
Secondary measured value	Volume flow

Design

Features	Fully welded maintenance-free sensor.
	Large diameter range DN25...3000
	Rugged liners approved for drinking water.
	Large standard range but also available in customer specific diameter, length and pressure rating.
Modular construction	The measurement system consists of a flow sensor and a signal converter. It is available as compact and as separate version. Additional information can be found in the documentation of the signal converter.
Compact version	With signal converter IFC 050: OPTIFLUX 2050C
	With signal converter IFC 100: OPTIFLUX 2100C
	With signal converter IFC 300: OPTIFLUX 2300C
Remote version	In wall (W) mount version with signal converter IFC 050: OPTIFLUX 2050W
	In wall (W) mount version with signal converter IFC 100: OPTIFLUX 2100W
	In field (F), wall (W) or rack (R) mount version with signal converter IFC 300: OPTIFLUX 2300F, W or R
Nominal diameter	With signal converter IFC 050: DN25...1200/1...48"
	With signal converter IFC 100: DN25...1200/1...48"
	With signal converter IFC 300: DN25...3000/1...120"

Measuring accuracy

Maximum measuring error	IFC 050: down to 0.5% of the measured value \pm 1 mm/s	
	IFC 100: down to 0.3% of the measured value \pm 1 mm/s	
	IFC 300: down to 0.2% of the measured value \pm 1 mm/s	
	The maximum measuring error depends on the installation conditions.	
	For detailed information refer to <i>Measuring accuracy</i> on page 19.	
Repeatability	\pm 0.1% of the measured value, minimum 1 mm/s	
Calibration / Verification	Standard:	
	2 point calibration by a direct volume comparison.	
	Optional:	
	Verification to Measurement Instrument Directive (MID), Annex MI-001. Standard: Verification at Ratio (Q3/Q1)=80, Q3 ω 2m/s Optional: Verification at Ratio (Q3/Q1)>80 on request	
MID Annex MI-001 (Directive 2004/22/EC)	EC-Type examination certificate to MID Annex MI-001	
	Only in combination with the signal converter IFC 300.	
	Diameter range: DN25...1600	
	Forward and reverse (bi-directional) flow	
	Liquid temperature range: +0.1°C/ +50°C	
	For detailed information refer to <i>Legal metrology</i> on page 15.	
OIML R49	Certificate of conformity to OIML R49	
	Only in combination with the signal converter IFC 300.	
	Diameter range	Class 1: DN65...1600
		Class 2: DN25...50
	Forward and reverse (bi-directional) flow	
	Liquid temperature range: +0.1°C/ +50°C	
For detailed information refer to <i>Legal metrology</i> on page 15.		

Operating conditions

Temperature	
For detailed information in pressure / temperature refer to <i>Pressure derating</i> on page 20.	
	For Ex versions different temperatures are valid. Please refer to the relevant Ex documentation for details.
Process temperature	Hard rubber liner: -5...+80°C / +23...+176°F
	Polypropylene liner: -5...+90°C / +23...+194°F
	Polyolefin liner: -5...+80°C / +23...+176°F
Ambient temperature	Standard (with aluminum signal converter housing): standard flanges -20...+65°C / -4...+149°F
	Option (with aluminum signal converter housing): low temperature carbon steel flanges or stainless steel flanges -40...+65°C / -40...+149°F
	Option (with stainless steel signal converter housing): low temperature carbon steel flanges or stainless steel flanges -40...+55°C / -40...+130°F
Protect electronics against self-heating at ambient temperatures above +55°C / +131°F.	
Storage temperature	-50...+70°C / -58...+158°F
Measuring range	-12...+12 m/s / -40...+40 ft/s

Pressure	
For detailed information in pressure / temperature refer to <i>Pressure derating</i> on page 20.	
EN 1092-1	DN2200...3000:PN2.5
	DN1200...2000:PN6
	DN200...1000:PN10
	DN65 and DN100...150:PN16
	DN25...50 and DN80: PN40
	Other pressures on request
ASME B16.5	1...24": 150 & 300lb RF
	Other pressures on request
JIS	DN50...1000 / 2...40": 10 K
	DN25...40 / 1...1½": 20 K
	Other pressures on request
AWWA (class B or D FF)	Option:
	DN700...1000 / 28...40": η 10 bar / 145 psi
	DN1200...2000 / 48...80": η 6 bar / 87 psi
DIN	PN16 – 6 bar rated; DN700...2000
	PN10 – 6 bar rated; DN700...2000
	PN6 – 2 bar rated; DN700...2000
Vacuum load	For detailed information refer to <i>Vacuum load</i> on page 22.
Pressure loss	Negligible
Chemical properties	
Physical condition	Electrically conductive liquids
Electrical conductivity	Standard: ω 5 μ S/cm
	Demineralised water: ω 20 μ S/cm
Permissible gas content (volume)	IFC 050: η 3%
	IFC 100: η 3%
	IFC 300: η 5%
Permissible solid content (volume)	IFC 050: η 10%
	IFC 100: η 10%
	IFC 300: η 70%

Installation conditions

Installation	Assure that the flow sensor is always fully filled.
	For detailed information refer to <i>Installation</i> on page 27.
Flow direction	Forward and reverse
	Arrow on flow sensor indicates flow direction.
Inlet run	ω 5 DN
Outlet run	ω 2 DN
Dimensions and weights	For detailed information refer to <i>Dimensions and weights</i> on page 23.

Materials

Flow sensor housing	Sheet steel
	Other materials on request
Measuring tube	Austenitic stainless steel
Flanges	Carbon steel
	Other materials on request
Liner	Standard:
	DN25...150 / 1...6": polypropylene
	DN200...3000 / 8...120": hard rubber
	Option:
	DN25...150 / 1...6": hard rubber
	DN200...1000 / 8...40": polyolefin
Protective coating	On exterior of the meter: flanges, housing, signal converter (compact version) and / or connection box (field version)
	Standard: polyurethane coating
	Option: subsoil coating, offshore coating
Connection box	Only for remote versions
	Standard: die-cast aluminum
	Option: stainless steel
Measuring electrodes	Standard: Hastelloy [®] C
	Option: stainless steel, titanium
	Other materials on request
Grounding rings	Standard: stainless steel
	Option: Hastelloy [®] C, titanium, tantalum
	Grounding rings can be omitted with virtual reference option for the signal converter IFC 300.
Reference electrode (optional)	Standard: Hastelloy [®] C
	Option: stainless steel, titanium
	Other materials on request

Process connections

Flange	
EN 1092-1	DN25...3000 in PN2.5...40
ASME	1...24" in 150 & 300 lb RF
JIS	DN25...1000 in 10...20 K
AWWA	DN700...2000 in 6...10 bar
Design of gasket surface	RF
	Other sizes or pressure ratings on request.

Electrical connections

	For full detail refer to the relevant documentation of the signal converter.
Signal cable (remote versions only)	
Type A (DS)	In combination with the signal converter IFC 050, IFC 100 and IFC 300 Standard cable, double shielded. Max. length: 600 m / 1968 ft (depends on electrical conductivity and flow sensor)
Type B (BTS)	Only in combination with the signal converter IFC 300 Optional cable, triple shielded. Max. length: 600 m / 1968 ft (depends on electrical conductivity and flow sensor)
I/O	For full details of I/O options, including data streams and protocols, see technical datasheet of the relevant signal converter.

Approvals and certificates

CE	
This device fulfils the statutory requirements of the EU directives. The manufacturer certifies successful testing of the product by applying the CE mark.	
For full information of the EU directive & standards and the approved certifications; please refer to the EU Declaration of Conformity or the website of the manufacturer.	
Hazardous area	
ATEX	Please check the relevant Ex documentation for details.
	Compact version with signal converter IFC 100
	II 2 GD
	Compact version with signal converter IFC 300
	II 2 GD or II 2(1) GD
	Remote version
FM	II 2 GD
	In combination with signal converter IFC 300
	Class I, Div. 2, Groups A, B, C and D
	Class II, Div. 2, Groups F and G
	Class III, Div. 2, Groups F and G
CSA	In combination with signal converter IFC 300
	Class I, Div. 2, Groups A, B, C and D
	Class II, Div. 2, Groups F and G
NEPSI	GYJ05234 / GYJ05237
	Ex me ia IIC T6...T3
	Ex de ia II T6...T3
	Ex qe ia IIC T6...T3
	Ex e ia IIC T6...T3
Other approvals and standards	
Custody transfer	Only in combination with the signal converter IFC 300.
	MID Annex MI-001 type examination certificate
	OIML R49 certificate of conformity
	Conformity with ISO 4064 and EN 14154
Drinking water approvals	Hard rubber liner: NSF / ANSI standard 61 / ACS, KTW (<60°C), DVGW-W270, KIWA on request.
	Polypropylene liner: ACS, KIWA/ATA, KTW, NSF / ANSI standard 61, DVGW-W270, WRAS
	Polyolefin liner: ACS, KIWA/ATA, KTW, DVGW-W270, WRAS
Protection category acc. to IEC 60529	Standard:
	IP 66/67, NEMA 4/4X/6
	Option:
	IP 68, NEMA 6P IP 68 is only available for separate design and with a stainless steel connection box.
Shock test	IEC 60068-2-27
	30 g for 18 ms
Vibration test	IEC 60068-2-64
	f = 20...2000 Hz, rms = 4.5 g, t = 30 min

2.2 Legal metrology

*OIML R49 and MID Annex MI-001 is **only** available in combination with the signal converter IFC 300!*

2.2.1 OIML R49

The OPTIFLUX 2300 has a certificate of conformity with the international recommendation OIML R49 (edition). The certificate has been issued by NMI (Dutch board of weight and measures).

The OIML R49 recommendation concerns water meters intended for the metering of cold potable and hot water. The measuring range of the flowmeter is determined by Q3 (nominal flow rate) and R (ratio).

The OPTIFLUX 2300 meets the requirements for water meters of accuracy class 1 and 2.

- For accuracy class 1, the maximum permissible error for water meters is $\pm 1\%$ for the upper flow rate zone and $\pm 3\%$ for the lower flow rate zones.
- For accuracy class 2, the maximum permissible error for water meters is $\pm 2\%$ for the upper flow rate zone and $\pm 5\%$ for the lower flow rate zones.

According to OIML R49, accuracy class 1 designation shall be applied only to flowmeter with $Q_3 \geq 100 \text{ m}^3/\text{h}$.

$$Q_1 = Q_3 / R$$

$$Q_2 = Q_1 * 1.6$$

$$Q_3 = Q_1 * R$$

$$Q_4 = Q_3 * 1.25$$



Figure 2-1: ISO flow rates added to figure as comparison towards OIML

X: Flow rate

Y [%]: Maximum measuring error

1 $\pm 3\%$ for class 1, $\pm 5\%$ for class 2 devices

2 $\pm 1\%$ for class 1, $\pm 2\%$ for class 2 devices

OIML R49 Class 1

DN	Span (R)	Flow rate [m ³ /h]			
		Minimum Q1	Transitional Q2	Permanent Q3	Overload Q4
65	630	0.1587	0.254	100	125
80	630	0.254	0.4063	160	200
100	630	0.3968	0.6349	250	312.5
125	630	0.6349	1.0159	400	500
150	630	0.6349	1.0159	400	500
200	1000	1.0	1.6	1000	1250
250	1000	1.6	2.56	1600	2000
300	1000	2.5	4.0	2500	3125
350	500	5.0	8.0	2500	3125
400	500	8.0	12.8	4000	5000
450	500	8.0	12.8	4000	5000
500	500	12.6	20.16	6300	7875
600	160	39.375	63	6300	7875
700	80	125	200	10000	12500
800	80	125	200	10000	12500
900	80	200	320	16000	20000
1000	80	200	320	16000	20000
1100	80	200	320	16000	20000
1200	80	200	320	16000	20000
1300	80	312.5	500	25000	31250
1400	80	312.5	500	25000	31250
1500	80	312.5	500	25000	31250
1600	80	312.5	500	25000	31250
1800	50	500	800	25000	31250

OIML R49 Class 2

DN	Span (R)	Flow rate [m ³ /h]			
		Minimum Q1	Transitional Q2	Permanent Q3	Overload Q4
25	400	0.040	0.064	16	20
32	400	0.0625	0.10	25	31.25
40	400	0.0625	0.10	25	31.25
50	400	0.10	0.16	40	50

For DN65 to DN1600; same values (DN, R, Q1, Q2, Q3, Q4) as for OIML R49 class 1 are applicable.

2.2.2 MID Annex III (MI-001)

All new designs of water meters that are to be used for legal purposes in Europe require certification under the Measurement Instrument Directive (MID) 2014/32/EU Annex III (MI-001). Annex MI-001 of the MID applies to water meters intended for the measurement of volume of clean, cold or heated water in residential, commercial and light industrial use. An EC-type examination certificate is valid in all countries of the European Union.

The OPTIFLUX 2300 has an EC-type examination certificate and can be verified to the MID Annex III (MI-001) for water meters with diameter DN25...DN1800.

The conformity assessment procedure followed for OPTIFLUX 2300 is Module B (Type Examination) and Module D (Quality Assurance of the Production Process).

The maximum permissible error on volumes delivered between Q₂ (transitional) flow rate and Q₄ (overload) flow rate is ± 2%.

The maximum permissible error on volumes delivered between Q₁ (minimum) flow rate and Q₂ (transitional) flow rate is ± 5%.

$$Q_1 = Q_3 / R$$

$$Q_2 = Q_1 * 1.6$$

$$Q_3 = Q_1 * R$$

$$Q_4 = Q_3 * 1.25$$

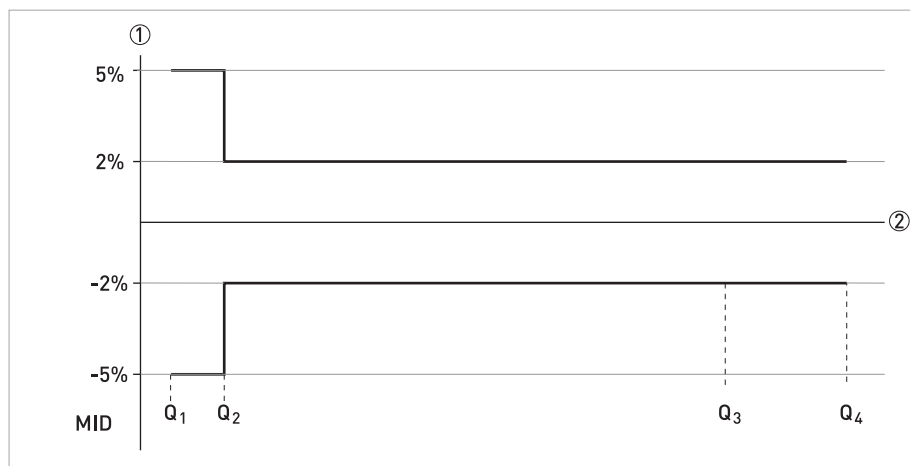

Figure 2-2: ISO flow rates added to figure as comparison towards MID

X: Flow rate

Y [%]: Maximum measuring error

MI-001certified flow characteristics

DN	Span (R) Q3 / Q1	Flow rate [m ³ /h]			
		Minimum Q1	Transitional Q2	Permanent Q3	Overload Q4
25	400	0.04	0.064	16	20
32	400	0.0625	0.10	25	31.25
40	400	0.0625	0.10	25	31.25
50	400	0.10	0.16	40	50
65	625	0.1587	0.254	100	125
80	640	0.254	0.4063	160	200
100	625	0.3968	0.6349	250	312.5
125	667	0.6349	1.0159	400	500
150	667	0.6349	1.0159	400	500
200	1000	1.0	1.6	1000	1250
250	1000	1.6	2.56	1600	2000
300	1000	2.5	4.0	2500	3125
350	500	5.0	8.0	2500	3125
400	500	8.0	12.8	4000	5000
450	500	8.0	12.8	4000	5000
500	500	12.6	20.16	6300	7875
600	160	39.375	63	6300	7875
700	80	125	200	10000	12500
800	80	125	200	10000	12500
900	80	200	320	16000	20000
1000	80	200	320	16000	20000
1100	80	200	320	16000	20000
1200	80	200	320	16000	20000
1300	80	312.5	500	25000	31250
1400	80	312.5	500	25000	31250
1500	80	312.5	500	25000	31250
1600	80	312.5	500	25000	31250
1800	59	500	800	25000	31250

2.3 Measuring accuracy

Every electromagnetic flowmeter is calibrated by direct volume comparison. The wet calibration validates the performance of the flowmeter under reference conditions against accuracy limits.

The accuracy limits of electromagnetic flowmeters are typically the result of the combined effect of linearity, zero point stability and calibration uncertainty.

Reference conditions

- Medium: water
- Temperature: +5...+35°C / +41...+95°F
- Operating pressure: 0.1...5 barg / 1.5...72.5 psig
- Inlet section: ω 5 DN
- Outlet section: ω 2 DN

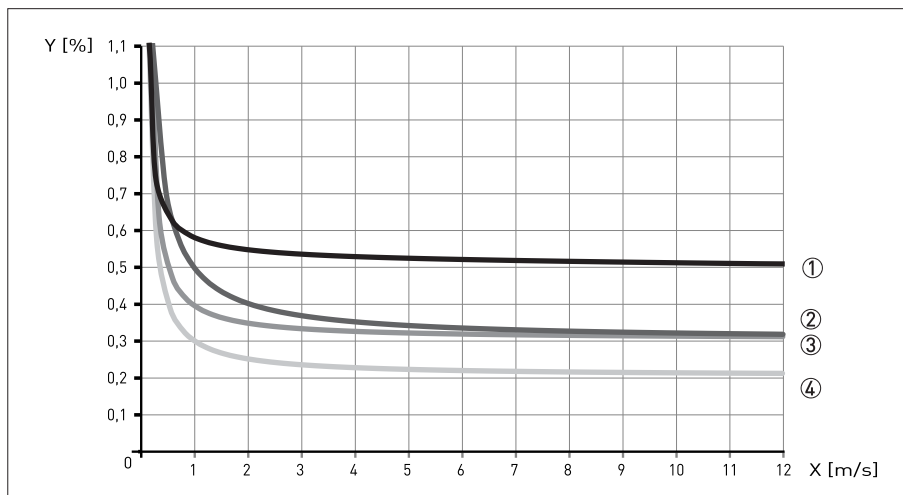

Figure 2-3: Flow velocity vs. accuracy
 X [m/s]: flow velocity
 Y [%]: deviation from the actual measured value (mv)

Accuracy

Flow sensor diameter	Signal converter type	Accuracy	Curve
DN25...1200 / 1...48"	IFC 050	0.5% of mv +1 mm/s	1
DN25...1200 / 1...48"	IFC 100	0.3% of mv +1 mm/s	3
DN25...1600 / 1...64"	IFC 300	0.2% of mv +1 mm/s	4
DN1800...3000 / >64"	IFC 300	0.3% of mv +2 mm/s	2

*Optionally for IFC 050 and IFC 100; extended calibration at 2 points for optimised accuracy.
 For more details on optimised accuracy, see the concerning signal converter documentation.*

2.4 Pressure derating

The graphs below refer to the maximum pressure as a function of the temperature for the flanges of the flowmeter (per specified flange material).

Please note that the specified values only refer to the flanges. The maximum value for the flowmeter can further be limited by the maximum value for other materials (i.e. the liner)

For A = Carbon steel A 105 & B = Stainless steel 316L

X/Yaxes in all graphs; X = Temperature in [°C] / Y = Pressure in [bar]
 x/yaxes in all graphs; x = Temperature in [°F] / y = Pressure in [psi]

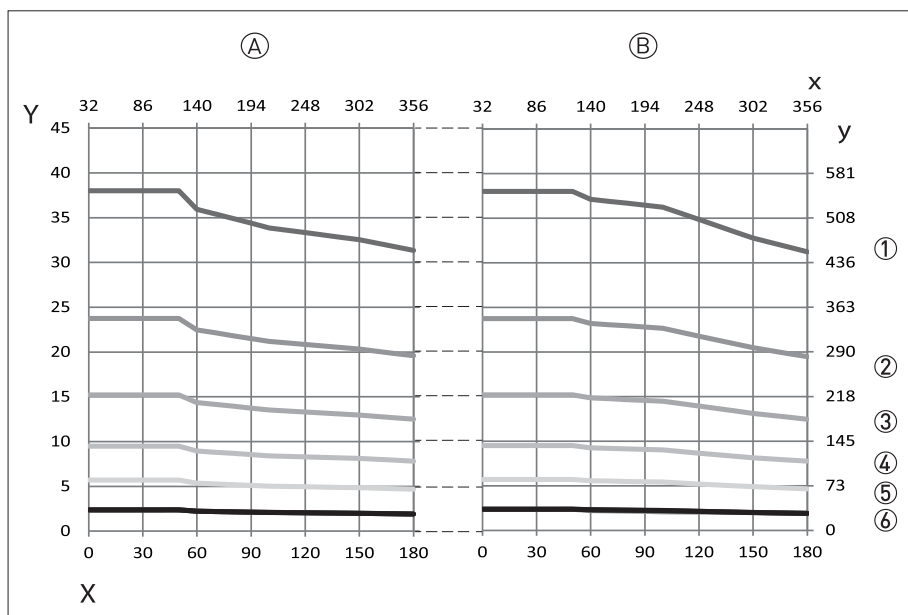

Figure 2-4: Pressure derating; EN 1092-1

- 1 PN 40
- 2 PN 25
- 3 PN 16
- 4 PN 10
- 5 PN 6
- 6 PN 2.5

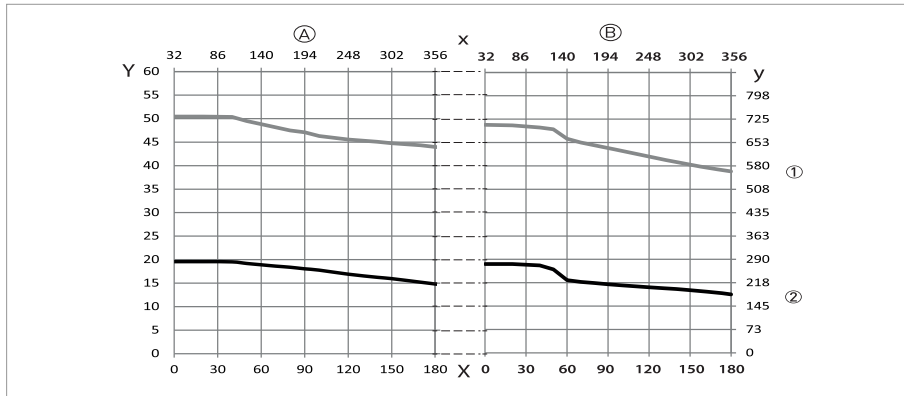

Figure 2-5: Pressure derating; ANSI B16.5

- 1 300lbs
- 2 150lbs

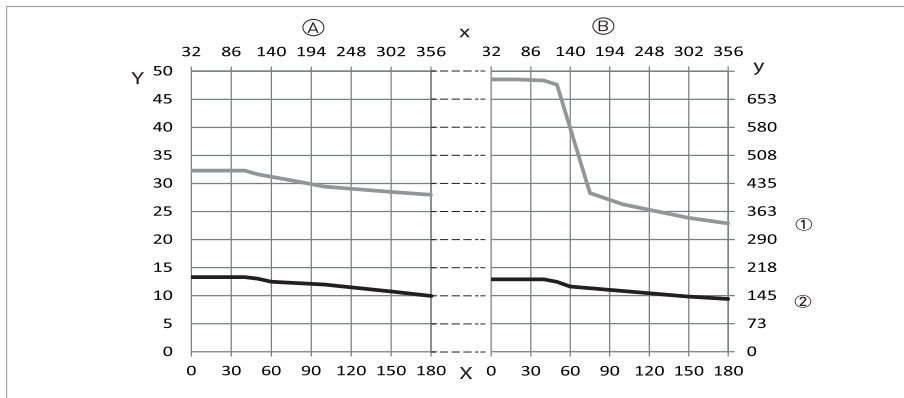

Figure 2-6: Pressure derating; JIS B2220

- 1 20K
- 2 10K

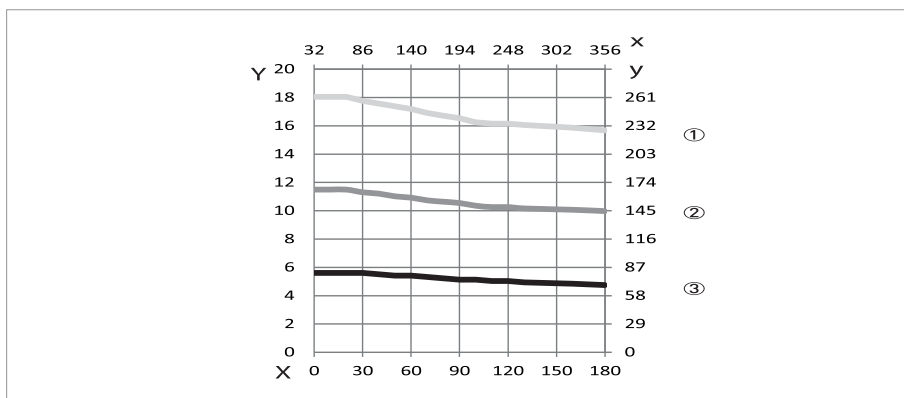

Figure 2-7: Pressure derating; AWWA C207

- 1 Class D1 [4...12"]
- 2 Class D2 [>12"]
- 3 Class B

2.5 Vacuum load

Diameter	Vacuum load in mbar abs. at a process temperature of			
[mm]	20°C	40°C	60°C	80°C
Hard rubber				
DN200...300	250	250	400	400
DN350...1000	500	500	600	600
DN1200...3000	600	600	750	750
Polypropylene				
DN25...150	250	250	400	400
Polyolefin				
DN200...1000	0	0	0	0

Diameter	Vacuum load in psia at process temperature of			
[inch]	68°F	104°F	140°F	176°F
Hard rubber				
8...12	3.6	3.6	5.8	5.8
14...40	7.3	7.3	8.7	8.7
48...120	8.7	8.7	10.9	10.9
Polypropylene				
1...6	3.6	3.6	5.8	5.8
Polyolefin				
8...40	0	0	0	0

2.6 Dimensions and weights

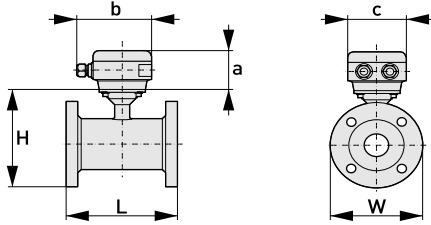
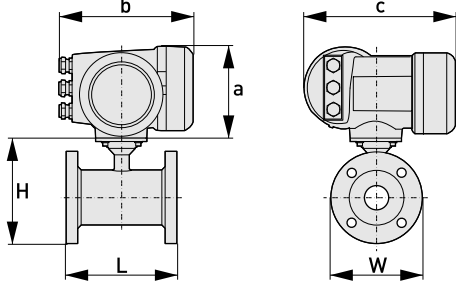
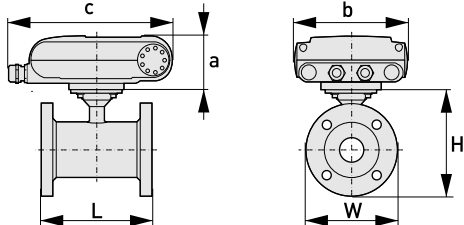
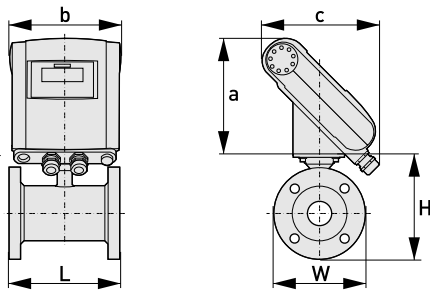
Remote version		<p>a = 88 mm / 3.5"</p> <p>b = 139 mm / 5.5" 1</p> <p>c = 106 mm / 4.2"</p> <p>Total height = H + a</p>
Compact version with : IFC 300		<p>a = 155 mm / 6.1"</p> <p>b = 230 mm / 9.1" 1</p> <p>c = 260 mm / 10.2"</p> <p>Total height = H + a</p>
Compact version with: IFC 100(0°)		<p>a = 82 mm / 3.2"</p> <p>b = 161 mm / 6.3"</p> <p>c = 257 mm / 10.1" 1</p> <p>Total height = H + a</p>
Compact version with: IFC 100(45°)		<p>a = 186 mm / 7.3"</p> <p>b = 161 mm / 6.3"</p> <p>c = 184 mm / 7.3" 1</p> <p>Total height = H + a</p>

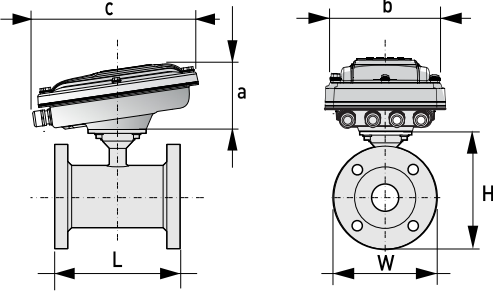
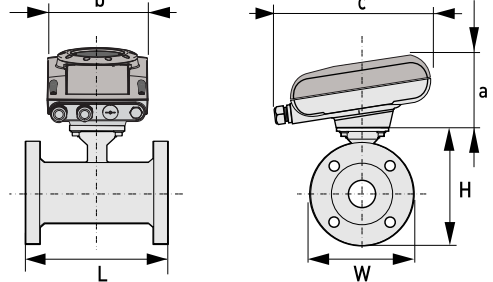
<p>Compact version with: stainless steel IFC 100 (10°)</p>		<p>a = 100 mm / 4" b = 187 mm / 7.36" ¹ c = 270 mm / 10.63" Total height = H + a</p>
<p>Compact version with: IFC 050(10°)</p>		<p>a = 101 mm / 3.98" b = 157 mm / 6.18" ¹ c = 260 mm / 10.24" ¹ Total height = H + a</p>

1 The value may vary depending on the used cable glands.

- All data given in the following tables are based on standard versions of the flow sensor only.
- Especially for smaller nominal sizes of the flow sensor, the signal converter can be bigger than the sensor.
- Note that for other pressure ratings than mentioned, the dimensions may be different.
- For full information on signal converter dimensions see relevant documentation.

EN 1092-1

Nominal size DN [mm]	Dimensions [mm]				Approx. weight [kg]
	Standard length	ISO Insertion length	H	W	
25	150	200	140	115	5
32	150	200	157	140	6
40	150	200	166	150	7
50	200	200	186	165	11
65	200	200	200	185	9
80	200	200	209	200	14
100	250	250	237	220	15
125	250	250	266	250	19
150	300	300	300	285	27
200	350	350	361	340	34
250	400	450	408	395	48
300	500	500	458	445	58
350	500	550	510	505	78
400	600	600	568	565	101
450	600	-	618	615	111
500	600	-	671	670	130
600	600	-	781	780	165
700	700	-	898	895	248
800	800	-	1012	1015	331
900	900	-	1114	1115	430
1000	1000	-	1225	1230	507
1200	1200	-	1417	1405	555
1400	1400	-	1619	1630	765
1600	1600	-	1819	1830	1035
1800	1800	-	2027	2045	1470
2000	2000	-	2259	2265	1860

ASME B16.5 / 150lb flanges

Nominal size [inch]	Dimensions [inch]			Approx. weight [lb]
	L	H	W	
1"	5.91	5.39	4.25	9
1¼"	5.91	5.75	4.63	13
1½"	5.91	6.10	5.00	15
2"	7.87	7.05	5.98	18
2½"	7.87	7.72	7	22
3"	7.87	8.03	7.50	26
4"	9.84	9.49	9.00	44
5"	9.84	10.55	10.00	49
6"	11.81	11.69	11.00	64
8"	13.78	14.25	13.50	95
10"	15.75	16.30	16.00	143
12"	19.69	18.78	19.00	207
14"	27.56	20.67	21.00	284
16"	31.50	22.95	23.50	364
18"	31.50	24.72	25.00	410
20"	31.50	26.97	27.50	492
24"	31.50	31.38	32.00	675

ASME B16.5 / 300lb flanges

Nominal size [inch]	Dimensions [inch]			Approx. weight [lb]
	L	H	W	
1"	5.91	5.71	4.87	11
1¼"	7.87	6.30	5.25	17
1½"	7.87	6.65	6.13	20
2"	9.84	7.32	6.50	22
2½"	9.84	7.95	7.5	25
3"	9.84	8.43	8.25	31
4"	11.81	10.00	10.00	44
6"	12.60	12.44	12.50	73
8"	15.75	15.04	15.00	157
10"	19.69	17.05	17.50	247
12"	23.62	20.00	20.50	375
14"	27.56	21.65	23.00	474
16"	31.50	23.98	25.50	639
20"	31.50	28.46	30.50	937
24"	31.50	33.39	36.00	1345

3.1 Intended use

Responsibility for the use of the measuring devices with regard to suitability, intended use and corrosion resistance of the used materials against the measured fluid lies solely with the operator.

The manufacturer is not liable for any damage resulting from improper use or use for other than the intended purpose.

The OPTIFLUX 2000 electromagnetic flowmeter is designed exclusively to measure the flow of electrically conductive, liquid media.

3.2 .General notes on installation

Inspect the packaging carefully for damages or signs of rough handling. Report damage to the carrier and to the local office of the manufacturer.

Do a check of the packing list to make sure that you have all the elements given in the order.

Look at the device nameplate to ensure that the device is delivered according to your order. Check for the correct supply voltage printed on the nameplate.

3.2.1 Vibrations

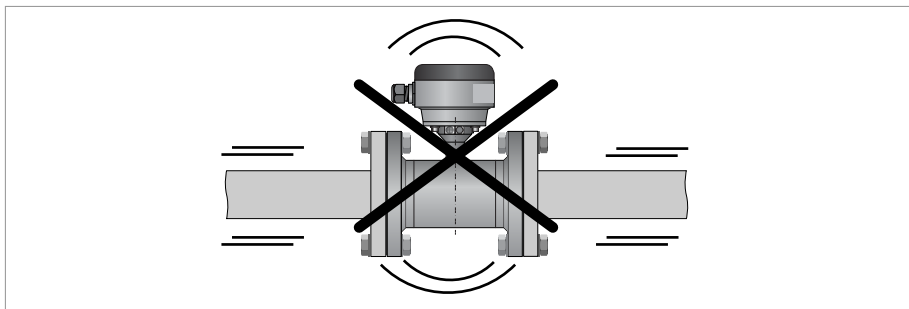

Figure 3-1: Avoid vibrations

3.2.2 Magnetic field

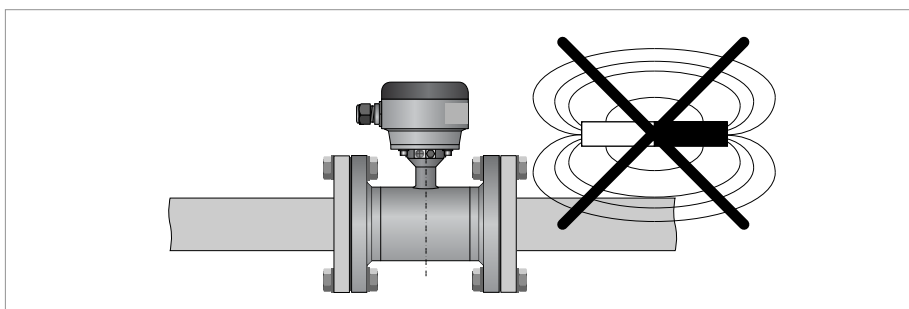

Figure 3-2: Avoid magnetic field

Keep at least 5 DN distance between electromagnetic flow sensors.

3.3 Installation conditions

3.3.1 Inlet and outlet

Use straight inlet and outlet pipe sections to prevent flow distortion or swirl, caused by bends and T-sections.

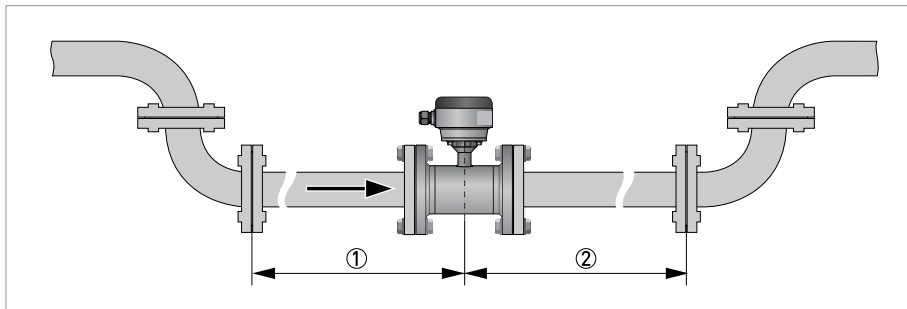

Figure 3-3: Recommended inlet and outlet section

- 1 Refer to chapter "Bends in 2 or 3 dimensions"
- 2 ω 2 DN

3.3.2 Bends in 2 or 3 dimensions

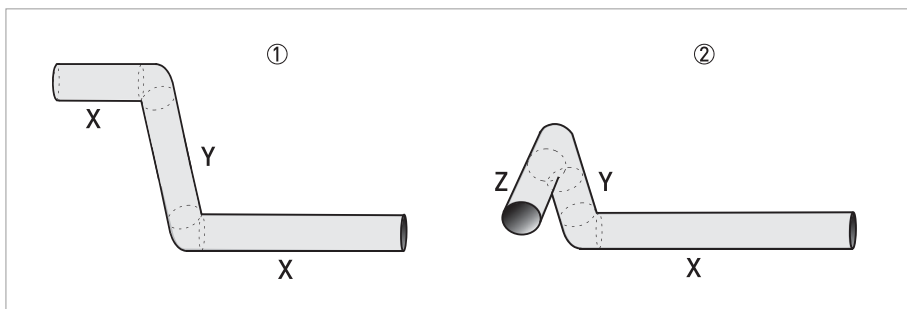

Figure 3-4: 2 and/or 3 dimensional bends upstream of the flowmeter

- 1 2 dimensions = X/Y
- 2 3 dimensions = X/Y/Z

Inlet length: using bends in 2 dimensions: ω 5 DN; when having bends in 3 dimensions: ω 10 DN

*2 dimensional bends occur in a vertical **or** horizontal plane (X/Y) only, while 3 dimensional bends occur in both vertical **and** horizontal plane (X/Y/Z).*

3.3.3 T-section

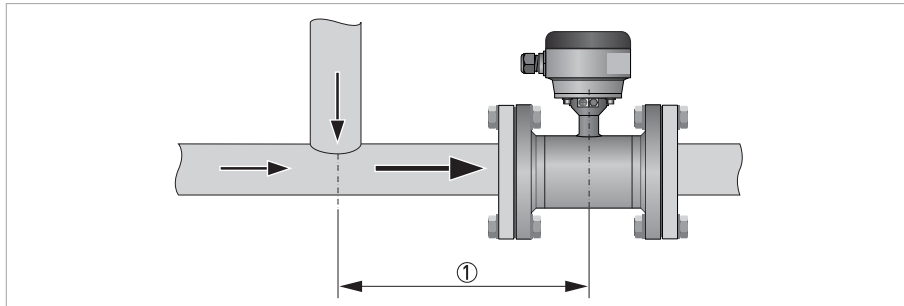

Figure 3-5: Distance behind a T-section

1 $\geq 10DN$

3.3.4 Bends

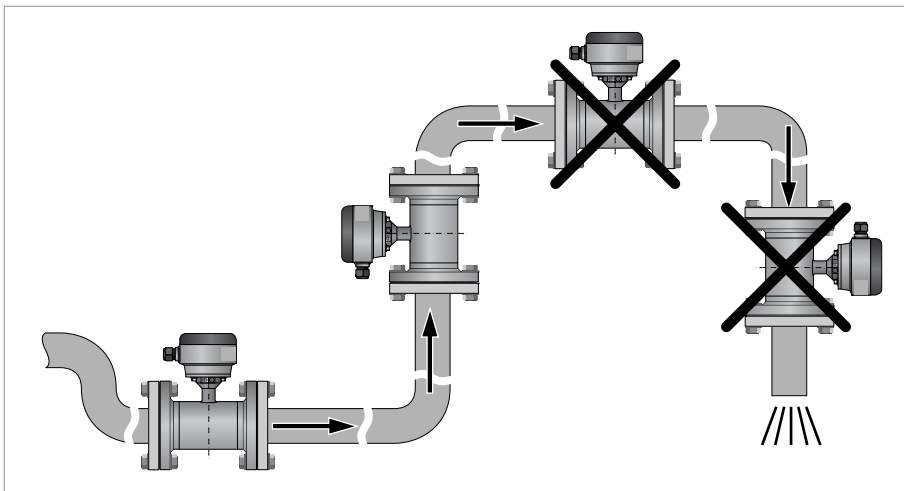

Figure 3-6: Installation in bending pipes (90°)

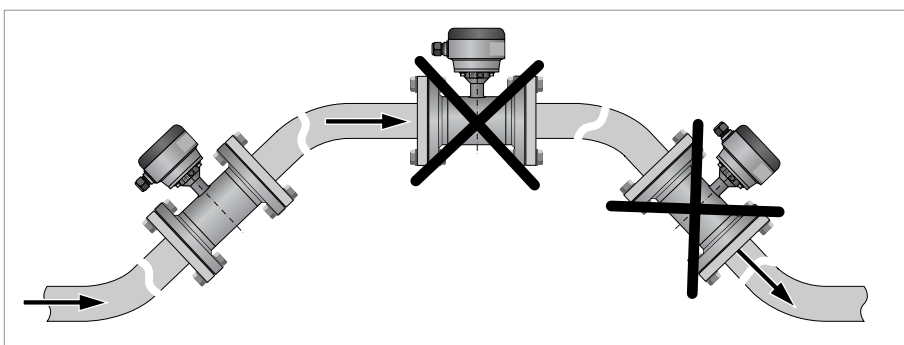

Figure 3-7: Installation in bending pipes (45°)

Avoid draining or partial filling of the flow sensor

3.3.5 Open discharge

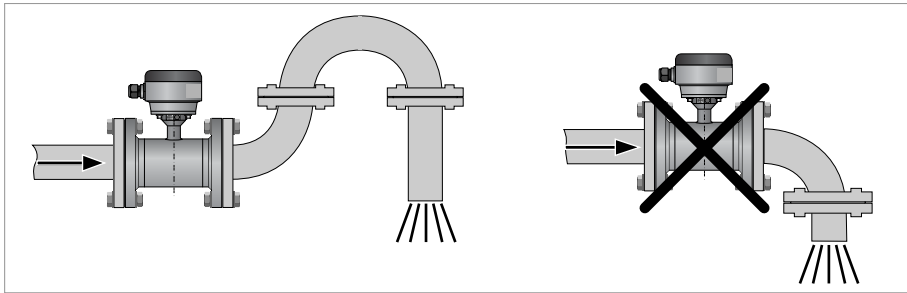

Figure 3-8: Installation in front of an open discharge

3.3.6 Flange deviation

Max. permissible deviation of pipe flange faces:
 $L_{max} - L_{min} \leq 0.5 \text{ mm} / 0.02''$

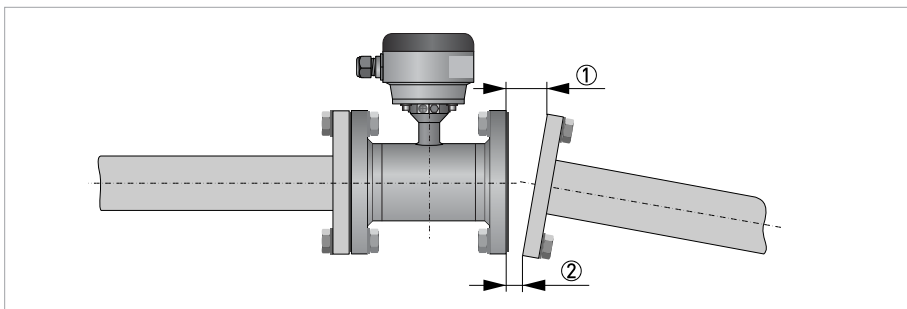

Figure 3-9: Flange deviation

- 1 L_{max}
- 2 L_{min}

3.3.7 Pump

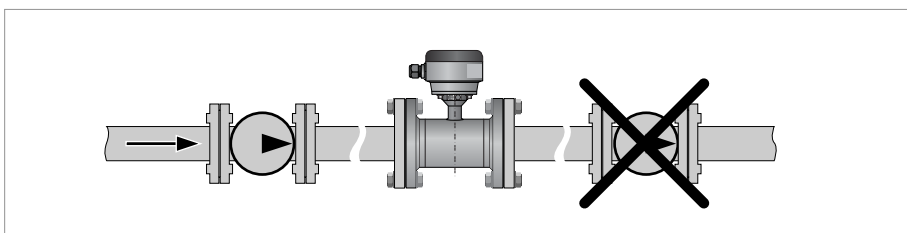

Figure 3-10: Installation behind a pump

3.3.8 Control valve

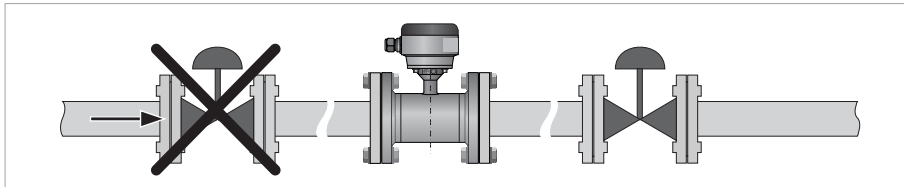

Figure 3-11: Installation in front of a control valve

3.3.9 Air venting and vacuum forces

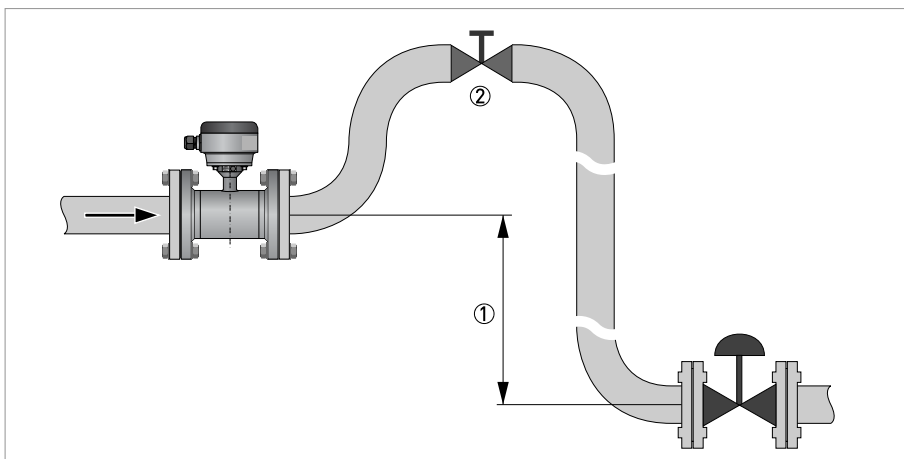

Figure 3-12: Air venting

- 1 \approx 5 m / 17 ft
- 2 Air ventilation point

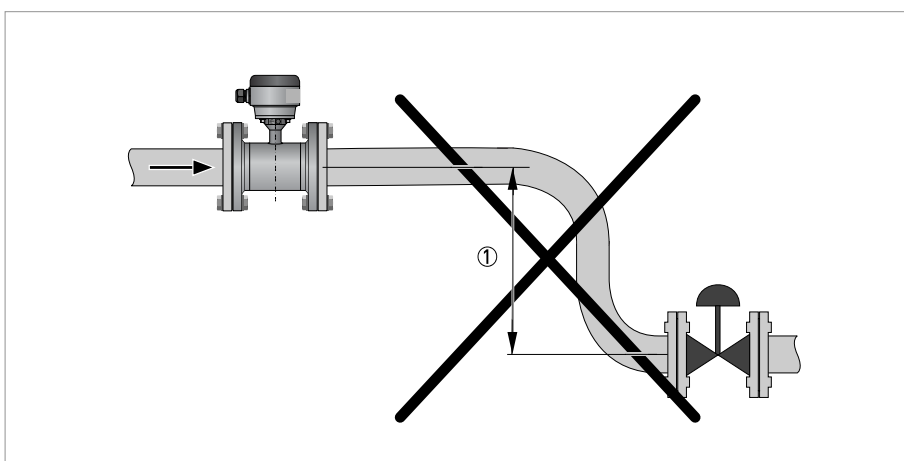

Figure 3-13: Vacuum

- 1 \approx 5 m / 17 ft

3.3.10 Mounting position

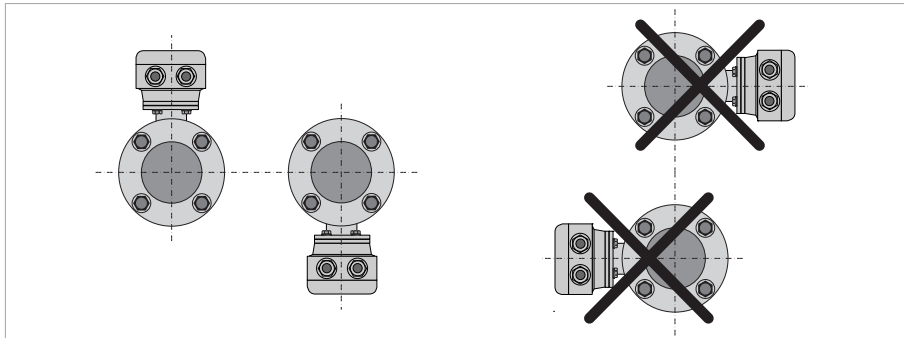

Figure 3-14: Mounting position

- Mount flow sensor either with signal converter aligned upwards or downwards.
- Install flow sensor in line with the pipe axis.
- Pipe flange faces must be parallel to each other.

3.4 Installation in a metering pit and subsurface applications

The OPTIFLUX 2000 flow sensor is rated IP 68, NEMA 6P. It is suitable for continuous submersion in flooded measurement chambers and can withstand a 10 meter water column. The flow sensor can also be installed (buried) underground (optional coating for subsurface application).

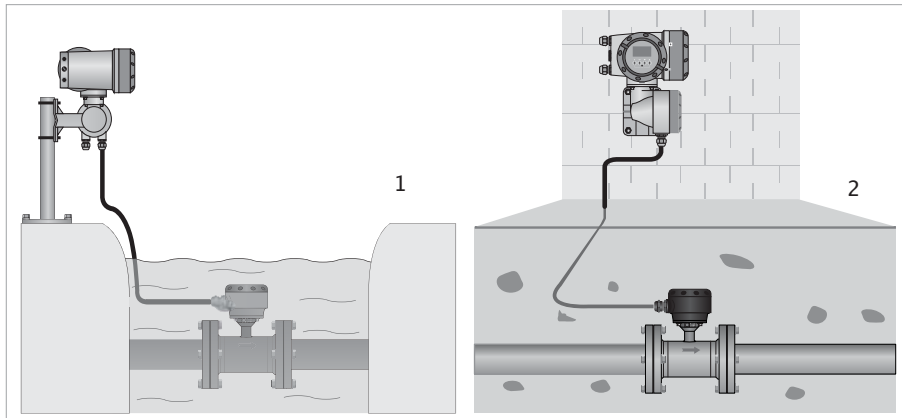

Figure 3-15: Examples of flooded and buried application

- 1 Submersible
- 2 Buried

The remote version of the IFC 050, IFC 100 and IFC 300 signal converters are IP 66/67, NEMA 4/4X rated and can be installed in a dry area on the wall of the measuring pit for visual read out of the display.

Submersion applications

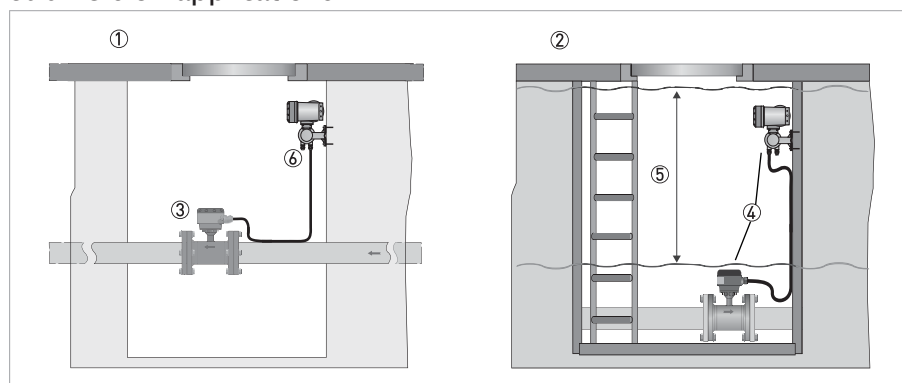

Figure 3-16: Examples of installation in measuring pit

- 1 Periodic submersion
- 2 Continuous submersion
- 3 Compact version
- 4 Remote version
- 5 Maximum water column 10 meter / 33 ft
- 6 Signal converter (remote)

It is recommended to place the cables in a protective tube. The standard IP 68 field version is available for special (customer installed) applications. Customer specified cables can be applied by the installer and connected according to IP 68 with the separate delivered two-component resin. Contact Product Support KROHNE for more cable specifications.

3.5 Mounting

Please take care to use the proper gasket to prevent damaging the liner of the flowmeter. In general, the use of spiral wound gaskets is not advised, as it could severely damage the liner of the flowmeter.

3.5.1 Torques and pressures

The maximum pressure and torques values for the flowmeter are theoretical and calculated for optimum conditions and use with carbon steel flanges.

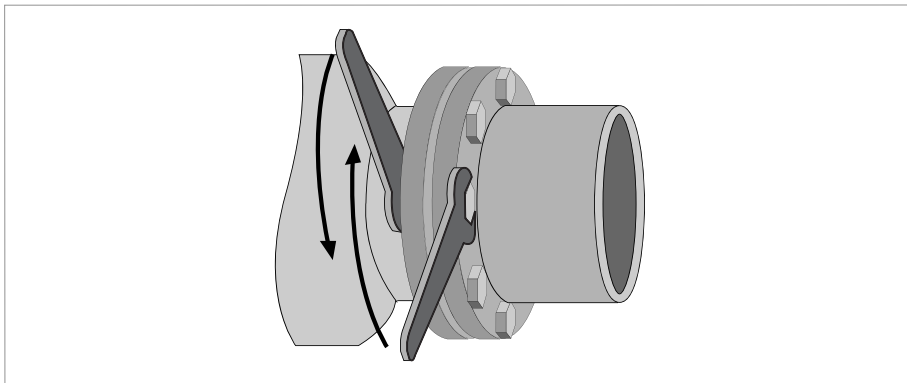

Figure 3-1 :Tightening of bolts

Tightening of bolts

- Always tighten the bolts uniformly and in diagonally opposite sequence.
- Do not exceed the maximum torque value.
- Step 1: Apply approx. 50% of max. torque given in table.
- Step 2: Apply approx. 80% of max. torque given in table.
- Step 3: Apply 100% of max. torque given in table.

Nominal size DN [mm]	Pressure rating	Bolts	Max. torque [Nm] ¹		
			Polyolefin	Polypropylene	Hard rubber
25	PN 40	4 x M 12	-	22	11
32	PN 40	4 x M 16	-	37	19
40	PN 40	4 x M 16	-	43	25
50	PN 40	4 x M 16	-	55	31
65	PN 16	2 x M 16	-	51	42
65	PN 40	8 x M 16	-	38	21
80	PN 40	8 x M 16	-	47	25
100	PN 16	8 x M 16	-	39	30
125	PN 16	8 x M 16	-	53	40
150	PN 16	8 x M 20	-	68	47
200	PN 10	8 x M 20	68	-	68
200	PN 16	12 x M 20	45	-	45
250	PN 10	12 x M 20	65	-	65
250	PN 16	12 x M 24	78	-	78
300	PN 10	12 x M 20	76	-	76
300	PN 16	12 x M 24	105	-	105
350	PN 10	16 x M 20	75	-	75
400	PN 10	16 x M 24	104	-	104
450	PN 10	20 x M 24	93	-	93
500	PN 10	20 x M 24	107	-	107
600	PN 10	20 x M 27	138	-	138
700	PN 10	24 x M 27	163	-	163
800	PN 10	24 x M 30	219	-	219
900	PN 10	28 x M 30	205	-	205
1000	PN 10	28 x M 33	261	-	261

- 1 The specified torque values are dependent on variables (temperature, bolt material, gasket material, lubricants, etc.) which are not within the control of the manufacturer. Therefore the values should be regarded as indicative only.
- 2 DN65 / PN16 is available with standard 8 bolt holes. On request 4 bolt holes is optional.

Other sizes / pressure ratings on request.

Nominal size [inch]	Flange class [lb]	Bolts	Max. torque [lbf.ft] ¹		
			Polyolefin	Polypropylene	Hard rubber
1	150	4 x 1/2"	-	6.7	3.2
1 1/2	150	4 x 1/2"	-	13	9
2	150	4 x 5/8"	-	24	17
3	150	4 x 5/8"	-	43	29
4	150	8 x 5/8"	-	34	23
6	150	8 x 3/4"	-	61	38
8	150	8 x 3/4"	51	-	51
10	150	12 x 7/8"	58	-	58
12	150	12 x 7/8"	77	-	77
14	150	12 x 1"	69	-	69
16	150	16 x 1"	67	-	67
18	150	16 x 1 1/8"	105	-	105
20	150	20 x 1 1/8"	94	-	94
24	150	20 x 1 1/4"	133	-	133
28	150	28 x 1 1/4"	119	-	119
32	150	28 x 1 1/2"	191	-	191
36	150	32 x 1 1/2"	198	-	198
40	150	36 x 1 1/2"	198	-	198

- ¹ The specified torque values are dependent on variables (temperature, bolt material, gasket material, lubricants, etc.) which are not within the control of the manufacturer. Therefore the values should be regarded as indicative only.

Nominal size [inch]	Flange class [lb]	Bolts	Max. torque [lbf.ft] ¹		
			Polyolefin	Polypropylene	Hard rubber
1	300	4 x 5/8"	-	11	5
1 1/2	300	4 x 3/4"	-	29	20
2	300	8 x 5/8"	-	18	13
3	300	8 x 3/4"	-	44	30
4	300	8 x 3/4"	-	69	47
6	300	12 x 3/4"	-	62	38
8	300	12 x 7/8"	60	-	60
10	300	16 x 1"	75	-	75
12	300	16 x 1 1/8"	113	-	113
14	300	20 x 1 1/4"	71	-	71
16	300	20 x 1 1/4"	92	-	92
18	300	24 x 1 1/4"	108	-	108
20	300	24 x 1 1/4"	121	-	121
24	300	24 x 1 1/2"	189	-	189

- 1 The specified torque values are dependent on variables (temperature, bolt material, gasket material, lubricants, etc.) which are not within the control of the manufacturer. Therefore the values should be regarded as indicative only.

Other sizes / pressure ratings on request.

- *Pressures are applicable at 20° C / 68° F.*
- *For higher temperatures, the pressure ratings are as per ASME B16.5.*

4.1 Safety instructions

*All work on the electrical connections may only be carried out with the power disconnected.
Take note of the voltage data on the nameplate!*

Observe the national regulations for electrical installations!

*Observe without fail the local occupational health and safety regulations.
Any work done on the electrical components of the measuring device may only be carried out by
properly trained specialists.*

*Look at the device nameplate to ensure that the device is delivered according to your order.
Check for the correct supply voltage printed on the nameplate.*

4.2 Grounding

*The device must be grounded in accordance with regulations in order to protect personnel
against electric shocks.*

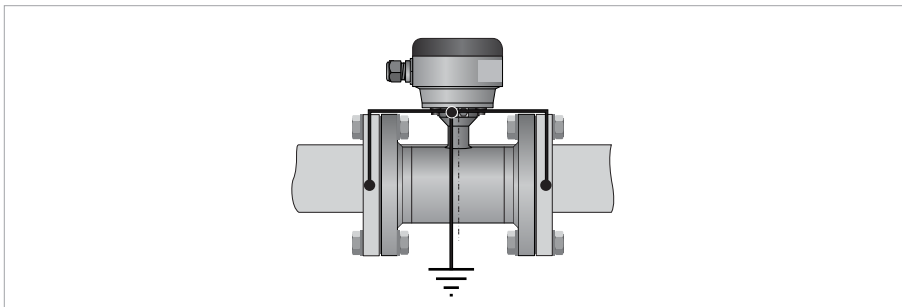

Figure 4-1: Grounding

Metal pipelines, not internally coated. Grounding without grounding rings.

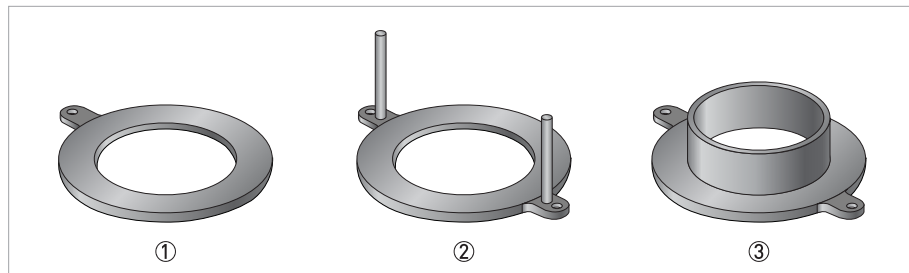

Figure 4-2: Different types of grounding rings

- 1 Groundingring number 1
- 2 Groundingring number 2
- 3 Groundingring number 3

Grounding ring number 1:

- Thickness : 3 mm / 0.1" (tantalum: 0.5 mm / 0.02")

Grounding ring number 2:

- Thickness : 3 mm / 0.1"
- Prevents damage to the flanges during transport and installation
- Especially for flow sensors tube with PTFE liner

Grounding ring number 3:

- Thickness : 3 mm / 0.1"
- With cylindrical neck (length 30 mm / 1.25" for DN10...150 / 3/8...6")
- Offers liner protection against abrasive fluids

4.3 Virtual reference for IFC 300(C, W and F version)

The virtual reference option on the signal converter IFC 300 provides complete isolation of the measurement circuit.

Benefits of virtual reference:

- Grounding rings or grounding electrodes can be omitted.
- Safety increases by reducing the number of potential leakage points.
- The installation of the flowmeters is much easier.

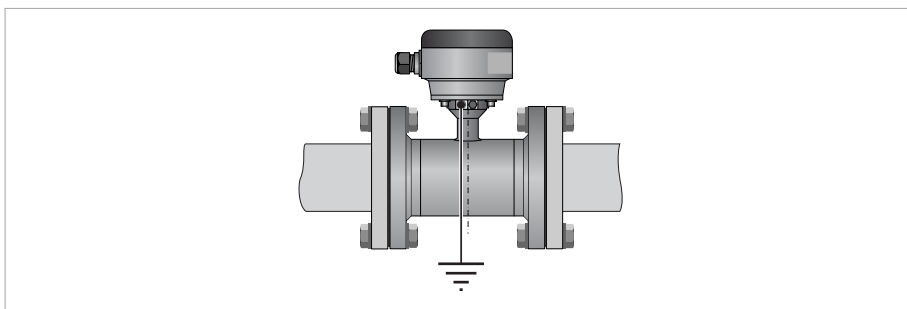

Figure 4-3: Virtual reference

Minimum requirements:

- Size: ω DN10 / 3/8"
- Electrical conductivity: ω 200 μ S/cm
- Signal cable: max. 50m / 164ft, type DS

4.4 Connection diagrams

For the connection diagrams and more information on connection of the sensor, please refer to the documentation of the applicable signal converter.







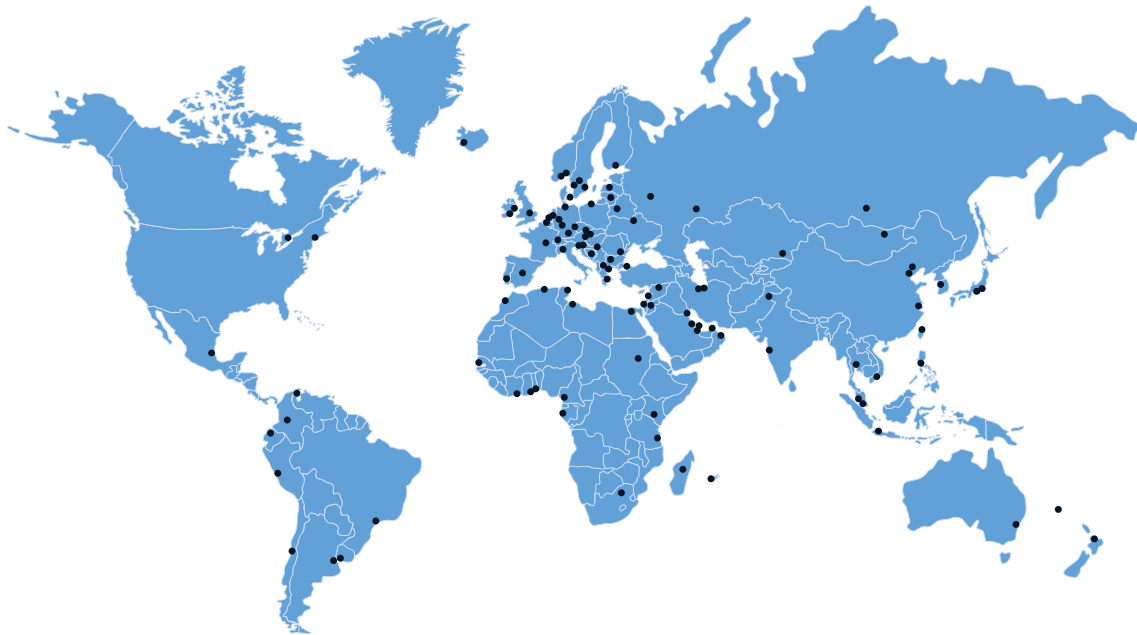

KROHNE – Process instrumentation and measurement solutions

- Flow
- Level
- Temperature
- Pressure
- Process Analysis
- Services

Head Office KROHNE Messtechnik GmbH
Ludwig-Krohne-Str. 5
47058Duisburg (Germany)
Tel.: +49203 301 0
Fax: +49203 301 10389
info@krohne.com

The current list of all KROHNE contacts and addresses
can be found at:
www.krohne.com



Intercontrol

IJsselburcht 26
6825 BP Arnhem
Tel. +31 (0) 26 4425 204

info@intercontrol.eu