



# Interface detection pipe probe

TSS90 DN(ANSI) .. SF TRV MTI50/0F3 AGd ExdG



- Measurement electronics factory set
- High-resolution measuring signal
- Pressure independent, stable measuring signal
- No moving parts
- PTFE-core
- No commissioning plug & process
- Process pressure PN16
- Process temperature 100 °C
- Insensitive to contamination

## Use

Can be used at oil terminals and at refineries at the exit of the stripping line or in the production plant, as well in storage tanks. For liquid/liquid phase separation of organics to aqueous media.

## Application

The pipe probe manufactured with stainless steel flanges in the standard version as sandwich-structured probe, combined with a PTFE inner body – including the measurement system – is applied as interface pipe probe for interface detection, separation, monitoring or as empty signal.

 **intercontrol**

**Intercontrol**

IJsselburcht 26  
6825 BP Arnhem  
Tel. +31 (0) 26 4425 204

[info@intercontrol.eu](mailto:info@intercontrol.eu)



Serial-no:

TAG-no:

## Model code:

TSS90 DN(ANSI) .. SF TRV MTI 50/0F3 AGd ExdG

TSS90	Pipe probe with PTFE measuring electrode in steel plane flange sandwich construction
DN	Flange DN 50, 80, 100, 125, 150 PN16   form A to EN 1092-1 ANSI 2, 3, 4" 150lbsASTM A182, ASME B16,5 RF
SF	Process connection on steel flange
TRV	Teflon® PTFE measuring body $s = 1.2$ mm, stainless steel 1.4404 flange, VITON seal
MTI	Measuring electronics device built in process condition selected MTI 50/.. AEO2 K
F3	For rainwater monitoring with min. change of MV up to $100 \mu\text{S}/\text{cm}$ or for phase separation with el. conductive organics up to $4000 \mu\text{S}/\text{cm}$
A	Analog measurement technology for interphase detection, product monitoring, full and empty signal
Gd	Measuring electronics - protective housing, (Outdoor), seawater-proof (Offshore) blue RAL 5007, seal: Silicon, EX/flameproof IP 68, cable gland brass Exd IP 66 M20 $\times$ 1.5, cable clamping range 9.5-16 mm

Probe Ex-protection: SEV 09 ATEX 0133 X CE 0036/1254

ExdG | (Gas-) Ex version (probe/MTI) II 1/2G Ex d ia IIC T6 Ga/Gb

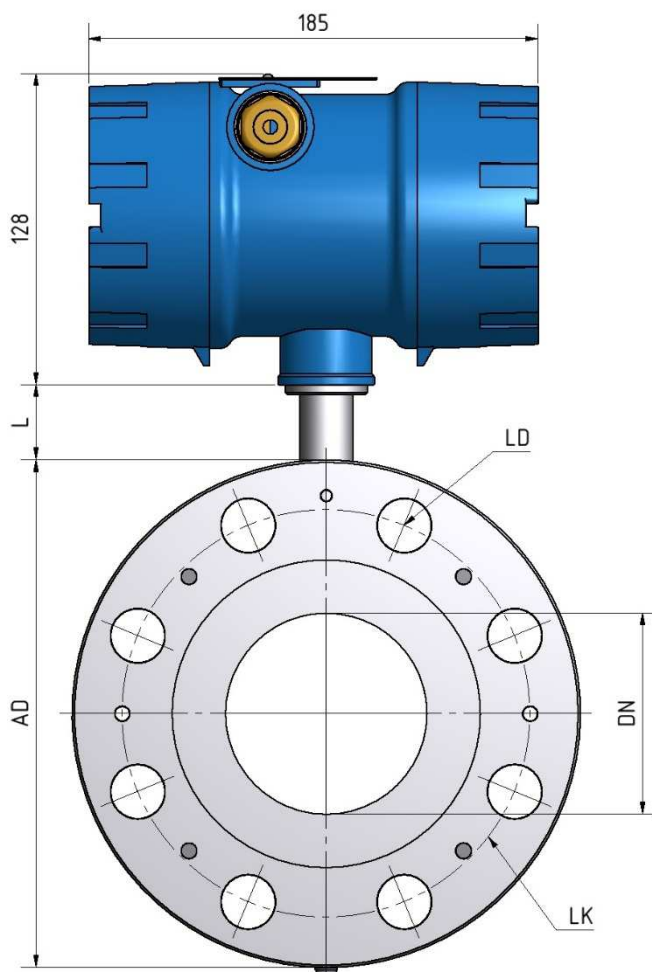

## Technical data

### Temperature range

-20 ... +100 °C medium | -20 ... +60 °C connection head

Cleaning temperature 210 °C max. 10 min pressureless (CIP)

Pressure -0.5 bar to max. 16 bar / 150 lbs. standard

Measuring principle Impedance

Measuring range DK 1.20 ... > 80  
measuring value water 2720 Imp.

Resolution < 6 Impulses

### Use for rainwater monitoring

MTI F3: 0...100  $\mu\text{S}/\text{cm}$  | MV max. > 10'000  $\mu\text{S}/\text{cm}$

Basic capacity  $C_p$ : 38 pF /  $R_p$ : 2.8 M $\Omega$

Integration time 40-400 ms / 0-3750 Imp

Use in Ex-Zone II 1/2G Zone 0

Measuring electrode PTFE-layer thickness  $s = 1.2$  mm

Application Interface detection for separation and monitoring

Measuring electronics Round housing MTI 50/.. AEO2K

Protection connection head round IP68 to EN 60529

### Wiring

Shielded 2-core cable 0.75 mm<sup>2</sup> twisted CY to all evaluation devices mipromex® cable length up to 1000 m or max.  
 $C = 150$  nF /  $R = 60 \Omega/\text{km}$  line impedance

Connection to evaluation unit mipromex® MIQ / MAT / MLS Exd

Article-n° 02.29.11.9000x

Nominal width	AD	DN	LD drilling	LK	Mounting height	FLA incl. Gasket
DN 50 PN 16/40	165	50	4 x ø 18	125	40	44
DN 80 PN 16/40	200	80	8 x ø 18	160	40/48	44/52
DN 100 PN 16	220	100	8 x ø 18	180	40	44
DN 125 PN 16	250	125	8 x ø 18	210	44	48
DN 150 PN 16	285	150	8 x ø 20	240	44	48
ANSI 2" 150 lbs	152.4	50	4 x ø 19.1	120.7	40	44
ANSI 2" 300 lbs	165.1	50	8 x ø 19.1	127.0	44.6	48.6
ANSI 3" 150 lbs	190.5	80	4 x ø 19.1	152.4	47.8	51.8
ANSI 3" 300 lbs	209.5	80	8 x ø 22.3	168.1	56.8	60.8
ANSI 4" 300 lbs	254.0	100	8 x ø 22.3	200.1	63.4	67.4

## Technical data on-site MTI F3 measuring electronics

### Design type

Plug-in electronics with square stainless cover in the protective housing, with HF-connection; IP 20

### Installation

Protection housing with mounting holes, plug-in electronics pluggable, fixed with 2 screws M4x8

### Performance

Linear conversion of an impedance range into a normed digital measurement signal

### Use / Display

One-time compensation of basic capacity of the RF cable and uncovered dry probe, LED display for quick adjustment

### Dimensions

Square model height x width x length 57 x 80 x 175 mm

### Weight electronics

140 g

### Ex-power supply / connection wiring (only Ex ia)

Shielded two-wire connection 0.75 mm<sup>2</sup> twisted CY/EIG to all evaluation devices mipromex® cable length up to 200 m or max. C = 120 nF / R = 30 Ohm line impedance

### Transfer signal

Impulse parcel, superimposed on the supply current

### Measuring voltage / current

U ~ 14.5 V I ~ 13.5 mA

### Nominal data of the supply voltage

Rate data Ex ia IIC only for connection to mipromex®-or\*TI\*K-units  
Circuit with the following maximum output values

$U_i \leq 18.9 \text{ V}$   $I_i \leq 49 \text{ mA}$

$P_i \leq 231 \text{ mW}$

$C_i = 60 \text{ nF}$   $L_i = 0 \text{ mH}$

For ignition protection type flameproof enclosure and intrinsic

Safety, Ex d ia IIC only for connection to mipromex® Typ M\*\* \*\*\*\*\*

Circuit with the following maximum output values

$U \leq 19.3 \text{ V}$   $I \leq 75 \text{ mA}$

### Ambient temperature

-20 ... +60 °C

### Storage temperature

-30 ... +80 °C, ideal +20 °C

### Measuring range

10 / 20 / 50 / 100 / 200 / 300 respective 0 up to max. 3750 impulses, special ranges available. The resolution range depends on the probe dimension and is product specific.

### Resolution

Max. 0.003 pF/impulses

### Norm range for pipe tube probe with detached MTI housing

Type TSS90 .../100/200/300

55 pF, type MTI 30/., 50/(0-16) basic adjustment range depending on probe and RF cable length, determined by the manufacturer

### Basic adjustment range

MTI .../. 0 to 16, 0 to 500 pF

### Measurement frequency

~ 2.8 MHz

### Linearity

Deviation < 0,1 % (without probe)

### Hysteresis

1 measured impulse

### Temperature influence 5 - 45 °C

Type MTI .../.A analog: < ± 3 measuring impulses

### Certification



Gas II 1/2G Ex ia Gb IIC T6  
II 1/2G Ex d ia IIC T6

RL 2014/34/EU

Inspection report n°: 08-IK-0395.01 with extension 1

Unit can be supplied without Ex-protection

### Intrinsically safe Ex-connection:

Measuring electronic MTI ... in a protective housing or tube probe type TSS80

EMC-tested, STS 024 report n° 990102WS

corresponds to EN 1127-1: 20011

EN 61000-6-2:2005 EN 6100-6-4: 2007

EN 60079-0: 2012 EN 60079-11: 2012



## Function

The impedance changes as a function of the dielectric constant and the el. conductivity of the organic and aqueous media, plus in partially filled, horizontal installed pipe probes. The measured impedance at the measuring electronics MTI is transformed directly into a normed digital sum signal and transmitted as a pulse train transmitted to the mipromex®.

## Mounting directions

- Installation position of a 3 % slope to vertical, depending on the application (see mounting directions for TSS)
- Installation independent of the flow direction
- Installation between two smooth flanges or flared, loose flanges only with special installation protection gaskets
- Caution! Note flange to flange distance for different nominal widths
- Additional flat gaskets "Gylon" (with appropriate tightening torque)
- Internal installation guidelines always have to be followed and suitable sealing types used.
- Observe internal safety regulations for open tanks
- Installation in pipes with appropriate nominal diameter with flat gasket and tightening torques (see mounting directions for TSS90)
- The pipe insulation must not enclose the cooling rod
- Ambient temperature: max. allowed temperature in the connection head must not exceed +60°C, if pipe probe is insulated and measuring electronics is detached installed
- The connection electronics MTI must be mounted at pipe temperatures of >60°C horizontal or downwards.
- Pressure tests have to be conducted with mounted probe
- Caution! Probe body is only leak-proof when flanged in.

## Disassembly instructions

- Empty tank and flush with nitrogen or water according to operating instructions (observe internal safety regulations)
- Disconnect electrical connections. Dismount probe, lift at the flange. Careful, residual liquid may leak out
- Data sheets for personal safety purpose need to be added with repair shipments to aquasant.

## Electrical directions

- Wiring must comply with the circuit and grounding diagram.
- Connections to MTI clamps 1/2, protected against polarity reversal, suitable for wire cross section 0.2 – 1.5 mm<sup>2</sup>
- The connecting cable has to suit the demands at the measuring circle.
- MTI-housing lid in [Ex ia] zone can be opened under live-line working.
- Output signal of mipromex® is a pulse modulated signal  $U_0 \leq 18.9V$

## Basic circuit diagram

Probe connection to evaluation unit mipromex®  
Connection diagram MRM4 Monorack DIN housing

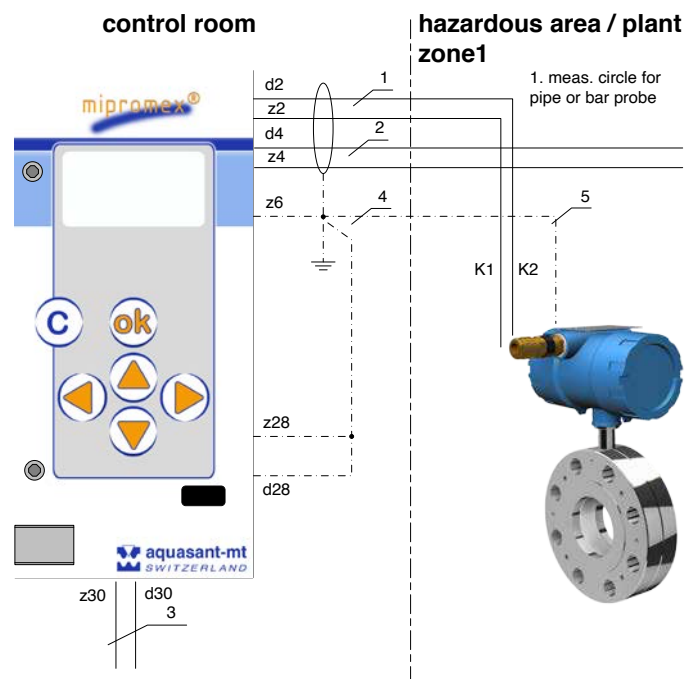

## Certificates

Explosion protection (ATEX)

EC-type examination SEV 09 ATEX 0133 X

- Ex certification according to the directive 2014/34EU

- Confidential test report no: 08-IK-0395.01

CE-Mark

The probe fulfills the legal requirements according to the EC directives. CE 1254