

## Aeration Air Flow Meter Series 410FTB

The Kurz410FTB flow meter is specifically designed to monitor aeration air flow in water and wastewater treatment facilities. Its response time to velocity changes coupled with its low noise signal allow for the highest control of dissolved oxygen (DO). By improving DO control in aeration basins, significant improvements in energy efficiency are realized. The 410FTB includes the following qualities and features:

- The fastest, lowest noise response to velocity changes in the industry.
- The highest repeatability, accuracy, and reliability available
- Constant temperature thermal technology
- No requirement for flow conditioners or minimum upstream metering runs for aeration applications
- Interchangeable sensor and electronics (single circuit board) — no matched sets
- Continuous self-monitoring electronics that verify the integrity of sensor wiring and measurements
- Zero velocity as a valid data point
- Sensor does not overheat at zero flow by using a unique constant temperature control method and power limiting design
- Completely field configurable using the local user interface or via a computer connection
- Supports HART, Profibus DP, and Modbus communication protocols
- Velocity dependent correction factors for dynamic flow profiles
- Sensor Blockage Correction Factor (SBCF)
- Flexibility with transmitter-attached or transmitter-separate designs
- Patented digital sensor control circuit (US 7,418,878)

Kurz Instruments is dedicated to manufacturing and marketing the best thermal mass flow meters available and to support our customers in their efforts to improve their businesses.



**intercontrol**

**Intercontrol**

IJsselburcht 26  
6825 BP Arnhem  
Tel. +31 (0) 26 4425 204

[info@intercontrol.eu](mailto:info@intercontrol.eu)



## SPECIFICATIONS

- **Velocity range**  
0 to 12,000SFPM (56 NMPS)
- **Velocity (v) accuracy**  
(SFPM at laboratory conditions)  
 $\pm(1 + 2000/v)\%$  of reading
- **<0.21% reading repeatability**
- **Response time ( $t_{63}$ )**  
0.18 seconds to 63% of final value
- **Noise (coefficient of variation)**  
0.2%
- **Temperature accuracy**  
 $\pm(0.5\%$  of reading  $+1^\circ\text{C}$ ) for velocities above 100SFPM
- **Electronics operating temperature**  
Integral display  
 $-13^\circ\text{F}$  to  $149^\circ\text{F}$  ( $-25^\circ\text{C}$  to  $65^\circ\text{C}$ )  
Remote aluminum enclosure  
 $-40^\circ\text{F}$  to  $149^\circ\text{F}$  ( $-40^\circ\text{C}$  to  $65^\circ\text{C}$ )  
Remote polycarbonate enclosure  
 $-13^\circ\text{F}$  to  $149^\circ\text{F}$  ( $-25^\circ\text{C}$  to  $65^\circ\text{C}$ )

## PROCESS CONDITIONS

- **Process pressure rating**  
Up to 50 PSIG (345 kPag)
- **Process temperature rating**  
 $-40^\circ\text{F}$  to  $347^\circ\text{F}$  ( $-40^\circ\text{C}$  to  $175^\circ\text{C}$ )
- **Installation requirement**  
The flow meter should be placed 3 line diameters or more upstream of the flow control valve

## CERTIFICATES & COMPLIANCES

- **Industrial Safety for Electrical Equipment**  
IEC/CSA/UL 61010-1
- **CE and UKCA compliance**  
EMC, LVD, PED, ROHS, and WEEE
- **NAMUR Signaling Standard NE43**  
Compliant 4–20mA Outputs
- **Based on SIL design**

## TRANSMITTER FEATURES

- **Aluminum (Type 4X, IP66) dual chamber polyester powder-coated enclosure**
- **Adjustable display/keypad orientation**
- **Optically-isolated loop powered 4–20mA output ( $\pm 48\text{VDC}$  isolation)**  
12-bit resolution and accuracy  
Maximum loop resistance is  $300\Omega$  at 18VDC,  $550\Omega$  at 24VDC,  $1400\Omega$  at 36VDC
- **Input power**  
AC (85–264V 50/60 Hz, 24 watts max.)  
or DC (24 V  $\pm 10\%$ , 1 A max.)
- **Integral or remote user interface**
- **Easy-to-use interface**  
Backlit display / keypad  
2-lines of 16-characters each
- **User-configurable flow display (scrolling or static)**
- **User-configurable English or metric units for mass flow rate, mass velocity, and process temperature**  
oC, oF, KGH, KGM, NCMH, NLPM, NMPS, PPD, PPH, PPM, SCFH, SCFM, SCMH, SFPM, SLPM, SMPS
- **Velocity-dependent correction factors for dynamic flow profiles**
- **Built-in zero-mid-spandrift check**
- **Built-in flow totalizers and elapsed time**
- **User-configurable digital filtering from 0 to 600 seconds**
- **Configuration/data access**  
USB or RS-485 Modbus (ASCII or RTU)
- **Meter memory**  
200 recent events, top 20 min/max, and 56 hours (10 second samples of trends)
- **3-year warranty**

## SUPPORT & ELEMENT COMPONENTS

- **Sensor material**  
Wetted sensor surfaces:  
SiO<sub>2</sub> glass, silicon rubber, 316L
- **Sensor support**  
316L stainless steel
- **Sensor support diameter**  
3/4" (19.05 mm)
- **Sensor support length**  
12" to 36" (305 mm or 914 mm)
- **3-year warranty**

## OPTIONS

- **Enclosures**  
Aluminum or remote-only polycarbonate wall mount
- **One 4–20mA non-isolated analog input**
- **Digital input dedicated to zero-mid-spandrift check**
- **Two optically isolated solid-state relays / alarms**  
Configurable as alarm outputs or pulsed totalizer output
- **Pulsed output as a remote flow totalizer**
- **Flow valve PID controller and configurable control application**  
Permits controlling set point velocity or flow rate through available control valve, damper, or 4–20mA interface
- **Hardware accessories**  
Available hardware includes flanges, ball valves, restraints, retractors, cable glands, conduit seals, cable, compression fittings, packing glands, and branch fittings
- **Communication protocols**  
RS-485 Modbus (ASCII or RTU), HART (v7 FSK) and PROFIBUS DP



## ANALOG & DIGITAL INPUTS & OUTPUTS

---

All options include USB interface with ASCII text and Modbus protocol through RS-485.

The 4–20mA analog outputs (AO) are used for flow rate and/or temperature, or one AO for PID flow control. All AO are NAMUR NE-43 compliant. Feature 9 option 42 (Standard) has AO1 that updates at a 15 Hz rate to support tighter flow loop control. Feature 9 options 45, 46 (HART) and 48 (Profibus) have AOs that update at the standard 4 Hz rate.

Relay digital outputs (DO) can be alarms, EPA zero–mid–span drift is active, or pulsed totalizer function. PID uses one 4–20mA output for flow control (motor speed, valve position, pressure, etc.). The EPA zero–mid–span drift check requires a contact closure to start the drift check. All 4–20mA outputs are used during the Drift Check Calibration process.

EPA zero–mid–span drift check can be initiated using digital inputs (DI), elapsed runtime automatic drift check, Modbus, or HART.

The 4–20mA analog input (AI) supports feedback to the device.



**SERIES 410FTB-12 OUTLINE DRAWINGS**

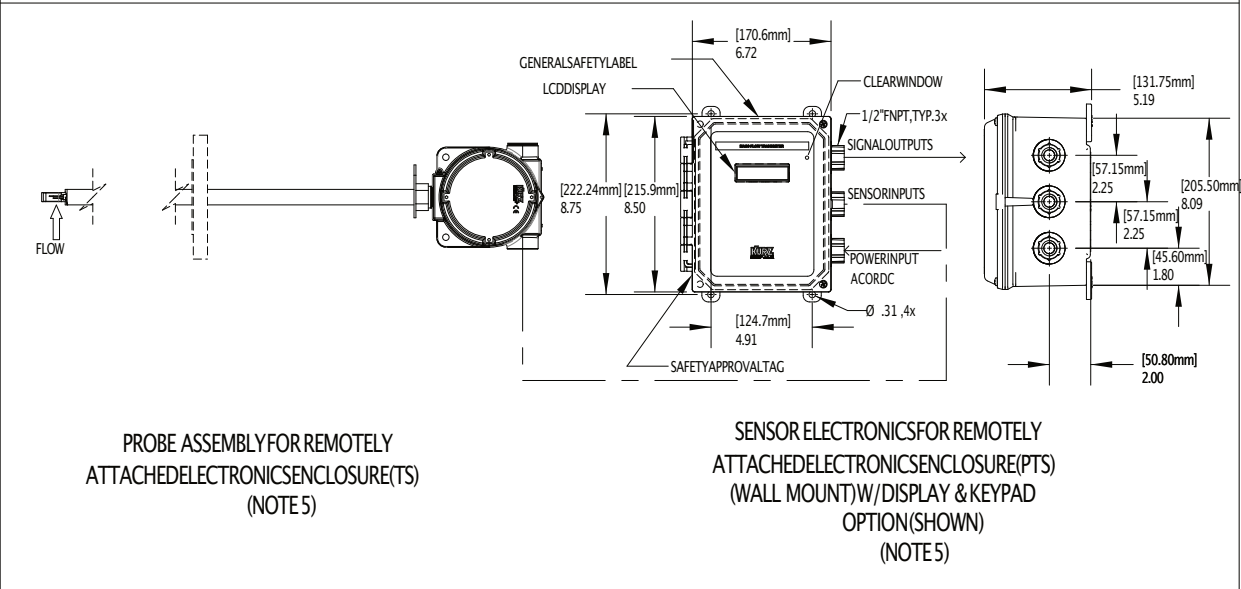
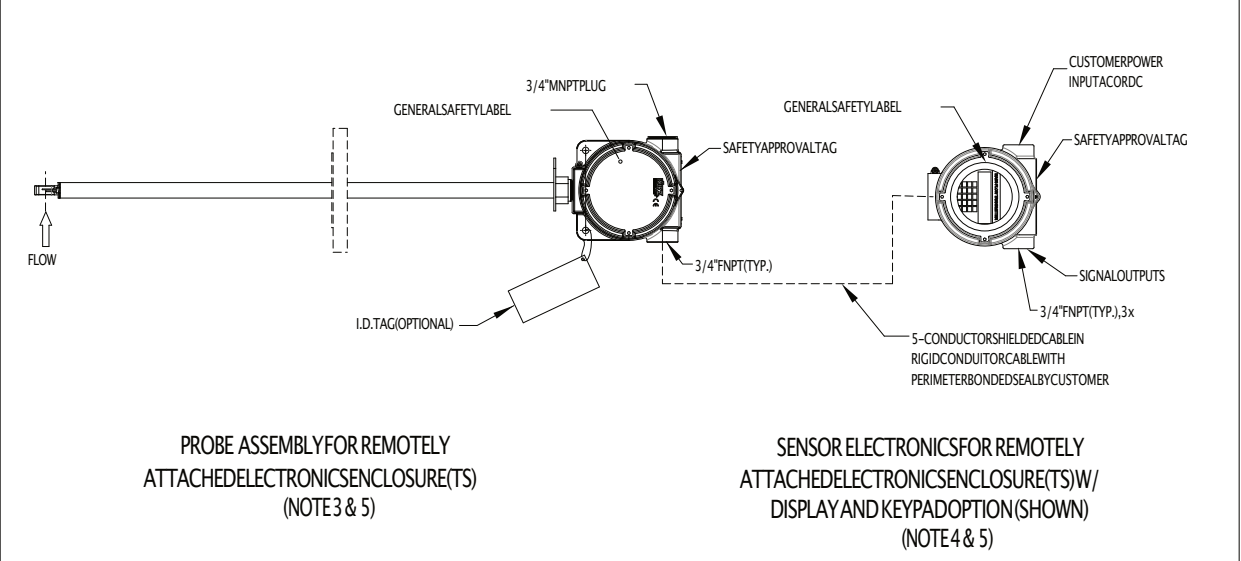
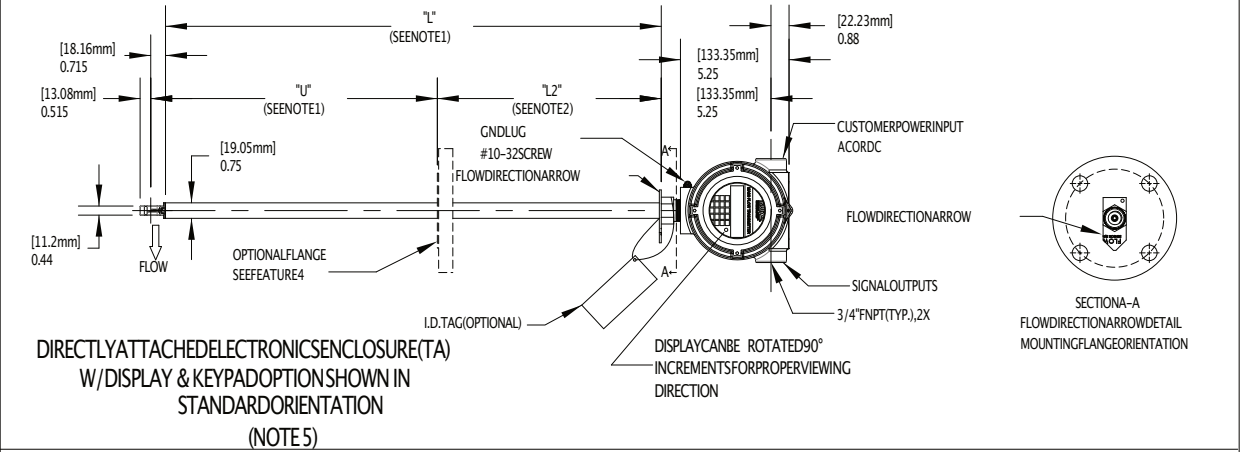

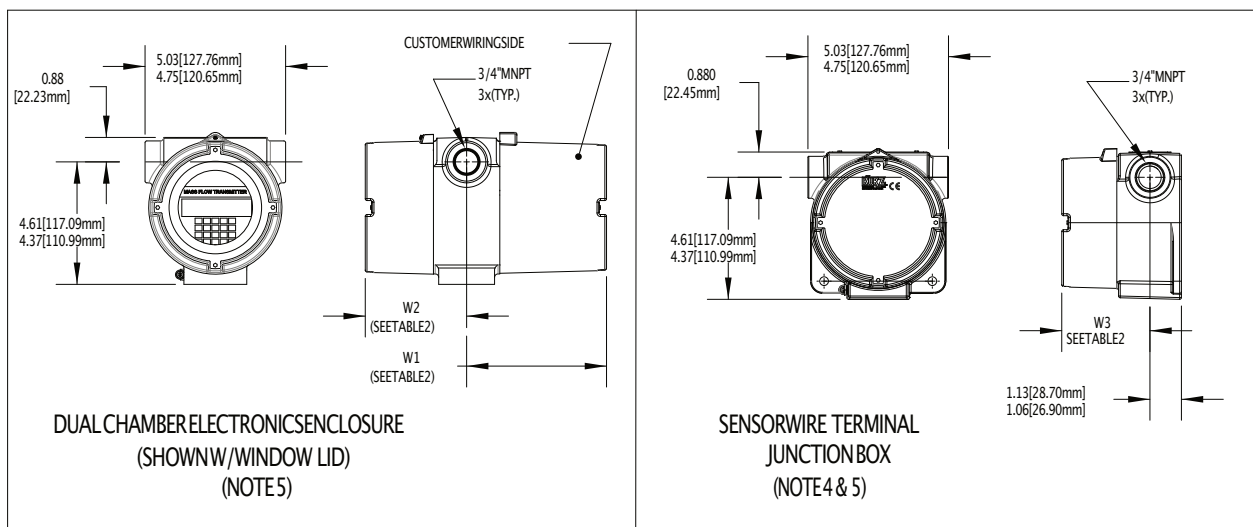

DUAL CHAMBER ELECTRONICS ENCLOSURE  
(SHOWN W/WINDOW LID)  
(NOTE 5)

SENSORWIRE TERMINAL  
JUNCTION BOX  
(NOTE 4 & 5)

TABLE 2. ENCLOSURE DIMENSION (NOTE 5)

POWER/ INPUT	DISPLAY/ KEYPAD	W1 (MAX.) (MIN.)	W2 (MAX.) (MIN.)	W3 (MAX.) (MIN.)
AC	YES	3.63 [92.20mm] 3.41 [88.61mm]	5.01 [127.25mm] 4.69 [119.13mm]	N/A
AC	NO	3.16 [80.26mm] 2.81 [71.37mm]	5.01 [127.25mm] 4.69 [119.13mm]	N/A
24VDC	YES	3.63 [92.20mm] 3.41 [88.61mm]	5.01 [127.25mm] 4.69 [119.13mm]	N/A
24VDC	NO (SEE NOTE 4)	N/A	N/A	5.01 [127.25mm] 4.69 [119.13mm]
SENSORWIRE TERMINAL JUNCTION BOX (FOR REMOTE OPTION)		N/A	N/A	3.16 [80.26mm] 2.81 [71.37mm]

NOTES:

- FOR FLANGED OPTION  $L = (U + L2 - 1.23 [31.24mm])$   
 $U (MIN.) = 4.00 [101.6mm]$
- $L2 (MIN.) = 5.00 [127.0mm]$
- THIS PROBE CONFIGURATION ALSO USED FOR DIRECTLY ATTACHED, DC POWERED, NO DISPLAY
- SENSORWIRE TERMINAL JUNCTION BOX USED FOR SENSOR ELECTRONICS FOR DC POWERED, NO DISPLAY
- ENCLOSURE STYLES AND DIMENSIONS ARE SUBJECT TO CHANGE



2411 Garden Road • Monterey, CA 93940 | 800-424-7356 • 831-646-5911 | www.KurzInstruments.com

755 0 6 0  
Parent number

B  
F1

2  
F2

—  
F3

—  
F4

—  
F5

—  
F6

1  
F7

A  
F8

—  
F9

A  
F10

—  
F11

Parent Number	Model
755060	410FTB

F1	Option	Probe Support Diameter
	B	0.75" (19 mm)

F2	Option	Probe Support & Flange Material
	2	316L stainless steel

F3	Option	Probe Support Length
	D	12" (305 mm)
	F	18" (457 mm)
	H	24" (610 mm)
	J	30" (762 mm)
	K	36" (914 mm)

F4	Compression Fittings or Flanges	
	Choose one only -None, Compression Fitting, or Flange	

Option	Compression Fittings
1A	None
2B	0.75" MNPT, stainless steel front and back ferrules
2D	0.75" MNPT, PTFE-compound front and back ferrules
2G	1" MNPT, stainless steel front and back ferrules
2J	1" MNPT, PTFE-compound front and back ferrules

Option 1 Class 150 lbs.	Option 2 Class 300 lbs.	ANSI 16.5 Flange
1A	1A	None
3D	4E	0.75" (19 mm)
3F	4G	1" (25 mm)
3J	4K	1.5" (38 mm)
3L	4M	2" (51 mm)

F5	Option	Flange U Dimension
		Enter 000 for no flange connection. Enter U-dimension to nearest 10th of an inch without a decimal point. For example, 7.7" is 077 and 23.6" is 236. <b>Note:</b> Convert metric units to English units.

F6	Option	Electronics & Enclosure Configuration <small>(Intended for use in Non-Hazardous Locations only)</small>
	A	Integral — Standard Enclosure Orientation for viewing Aluminum Type 4X, IP66 enclosure
	E	Integral — Enclosure Rotated 180° for viewing Aluminum Type 4X, IP66 enclosure
	J	Remote — Transmitter and sensing element separate Aluminum Type 4X, IP66 enclosures
	M	Remote — Transmitter and sensing element separate Sensor enclosure: Aluminum Type 4X, IP66 Electronics enclosure: Polycarbonate Type 4X, IP66

F7	Option	Display /Keypad
	1	Display /Keypad

F8	Option	Power <small>(Wiring Based)</small>
	A	AC (85–265V 47/63Hz, 24 watts max) or DC (24 V ±10%, 1 A max)

F9	Option	Communications and Inputs/Outputs
	42	Standard Two 4–20mA isolated outputs (AO1 is updated at a 15 Hz rate and AO2 is updated at a 1 Hz rate)
	45	HART-1 One 4–20mA isolated output, two relays, two digital inputs, one non-isolated 4–20mA input (AO1 is updated at a 4 Hz rate)
	46	HART-2 Two 4–20mA isolated outputs, two relays, two digital inputs, one non-isolated 4–20mA input (Both AOs are updated at a 4 Hz rate)
	48	Profibus DP Two 4–20mA isolated outputs, two relays, two digital inputs, one non-isolated 4–20mA input (Both AOs are updated at a 4 Hz rate)

F10	Option	Gas Type
	A	Air (laboratory calibration)

F11	Option	Velocity Calibration Range
	40	9,000 SFPM (41.9 NMPS)
	99	CUSTOM For velocities above 9000 SFPM (must specify)