



LDH-AAA-FCA-TF-S336 Laser distance sensor

Specifications / operating manual:



IECEx BVS 14.0108X

- ATEX and IECEx certified
- For use in Ex Zones (0), 1, 2
- Measurement range analog output: 0.05m to 30m
- Measurement range digital output: 0.05m to 30m
- High measurement accuracy
- Analog output signal 4mA to 20mA and serial data interface RS-485
- Easy alignment through visible red light laser
- Stainless steel 1.4404 housing



II 2(1)G

Ex db [op is Ga] IIA T3 Gb



| Technical Data | Type | LDH-AAA-FCA-TF | | | | |
|--|----------|---|----------|----------|--------------|--|
| Gas Ex protection designation | | II 2(1)G Ex db [op is Ga] IIA T3 Gb | | | | |
| For use in Ex Zones | | Zones (0), 1, 2 | | | | |
| Measurement methods | | Time-of-flight measuring | | | | |
| Light Source | | Laser Class 2, in accordance with EN 60825-1 | | | | |
| Maximum optical radiant intensity | | <=1mW, wave length: 650nm | | | | |
| Response time | | minimum 0.25s, maximum 4.5s | | | | |
| Pollution degree | | 4 | | | | |
| Utilization category | | D3A42AP1 | | | | |
| Supply voltage, Ue | | +24VDC | | | | |
| Absolute maximum supply voltage, Um | | 30VDC | | | | |
| Current consumption | | 70mA | | | | |
| Maximum power dissipation | | 2.4W | | | | |
| Typical measurement tolerance | | up to 10m: +/-1mm, applies for 100% target reflectivity, in low-light ambient, T _{amb} : 25°C | | | | |
| Maximum measurement tolerance | | up to 10m: +2mm, applies for 10% to 500% target reflectivity, in strong light ambient | | | | |
| Distance dependent increase of measurement tolerance | | <=0.15mm/m | | | | |
| Analog current output, type | | PNP, 4mA to 20mA, short circuit protected | | | | |
| Analog current outputs, operating range | | 0.05m to 30m (0.05m = 4mA, 30m = 20mA) | | | | |
| Analog current output, error indication | | 3.5mA: Measurement invalid 20.5mA: Object out of measurement range | | | | |
| Analog current output, resolution | | 1mm = 0,0005mA | | | | |
| Analog current output, load range | | 500R <= R _L <= 1000R | | | | |
| Serial interface, type | | RS 485, Format: 9600 baud, 8 data bits, 1 stop bit, Parity none, Handshaking none | | | | |
| Serial interface, range | | 0.05m to 30m | | | | |
| Serial interface, resolution | | 1mm | | | | |
| Input type | | START Input, PNP compatible | | | | |
| Input function | | "H" +24VDC: Starts measurement, "L" 0V: Stops measurement | | | | |
| Power up delay time | | 500ms | | | | |
| Housing | | M42, Material: Stainless steel 1.4404 | | | | |
| Enclosure rating | | IP67 | | | | |
| Ambient working temperature range, T _{amb} | | -10°C up to +35°C ¹ / -10°C up to +50°C ² | | | | |
| Storage temperature range | | -20°C up to +70°C | | | | |
| Relative humidity | | 15% ... 80% | | | | |
| Laser lifetime | | Appr. 30'000h, typically, at a housing temperature of +20°C. During continuous operation. Urgent recommendation: Apply 0V to the START-input, when no measurement is necessary | | | | |
| Connection cable | | Length: 5m, PUR jacket, 6+PE x 0.5mm ² , shielded, non-halogen, leads numbering marked, good chemical resistance, drag chain suitable | | | | |
| Options | | • Cable length: Up to 100m, upon request | | | | |
| Accessories | | <table border="1"> <thead> <tr> <th>Included</th> <th>Optional</th> </tr> </thead> <tbody> <tr> <td>• 2 nuts M42</td> <td></td> </tr> </tbody> </table> | Included | Optional | • 2 nuts M42 | |
| Included | Optional | | | | | |
| • 2 nuts M42 | | | | | | |
| Notes | | ¹ For a longer life time of the laser diode, the housing temperature of +35°C must not be exceeded. ² For housing temperature larger than +35°C use the sensor in pulse mode. See please document "Datasheet supplement" | | | | |

LDH-AAA-FCA-TF_e3/2020-07-27/MP

Electrical connection

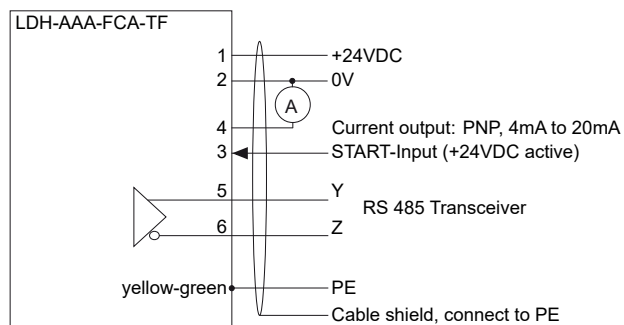
| Wire number | Function |
|--------------|----------------------------------|
| 1 | +24VDC |
| 2 | 0V |
| 3 | START-Input (+24VDC active) |
| 4 | Current output: PNP, 4mA to 20mA |
| 5 | RS 485 - Y |
| 6 | RS 485 - Z |
| yellow-green | PE |
| white | Cable shield |

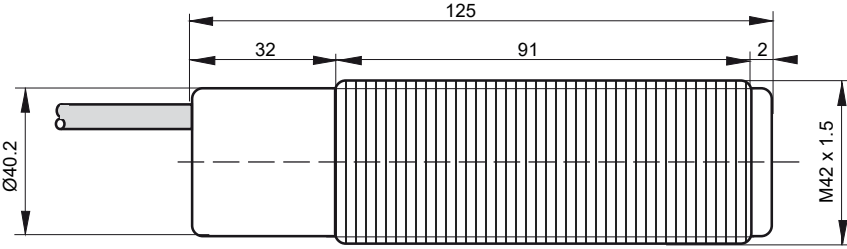
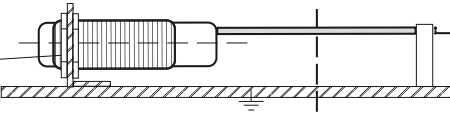

| | | | | | | | |
|--|--|--------------------------|-----------------------|--|------------------------|--|--|
| <p>EX related markings</p> | <p>CE 0158 Typ: LDH-AAA-FCA-TF Gas: II 2(1)G Ex db [op is Ga] IIA T3 Gb ATEX: IECEX: Tamb: Manufacturing date:</p> <p>Manufacturer with Address Electrical data according table</p> <p>BVS 10 ATEX E 130 X BVS 14.0108X -10°C up to +35°C Number 5 to 8 of the Serial Number (Year / CW)</p> | | | | | | |
| <p>Dimensions</p> |  | | | | | | |
| <p>Safe equipotential bonding for Ex devices</p> |  <p>Check the reliable, noncorrosive holding of the protection earth connection.</p> <p>The end of the cable must be connected outside the hazardous locations.</p> <p>The cable shield is to connect to PE in a wide area.</p> | | | | | | |
| <p>Operating Manual / EC-/EU-declaration of conformity</p> | | | | | | | |
| <p>Intended Use The distance sensor type LDH-AAA-FCA-TF is designed to measure distances within potentially explosive atmospheres. It must be installed and operated in accordance to this operating manual.</p> <p>Installation prescriptions for Ex hazardous locations It is necessary to take into consideration the valid international and national rules and regulations (EN 60079-14). The local potential equalization must be connected with the PA-connector using a reliable and noncorrosive connection. The PE/PA connector is permanently attached to the enclosure. The absolute maximum supply voltage $U_m = 30VDC$ must not be exceeded. No external parts are allowed for focusing or reshaping of the emitted laser beam, except for original parts. The cable must be protected against damaging. The end of the cable must either be installed within a certificated Ex housing or must be installed outside of any Ex area.</p> <p>Type LDH-AAA-FCA-TF: Allowed to be installed and operated within Ex zones 1 and 2. The limited optical radiation can operate into hazardous locations zones 0.</p> <p>General Installation Prescriptions Do not exceed the maximum ratings. The electrical connections must be exactly as shown in the connection diagram. The cable shield must be connected short. The cable shield must be connected to the protection earth, large-surfaced. Connection cables must not be installed parallel to high voltage cables. The cable shield is to connect at PE.</p> <p>Function The sensor uses the time of flight measurement principle. The travel time of an emitted pulse of light is measured, whereby the pulse travels from the sensor to the measured object and back. The relation between distance and travel time is given by the speed of light. This measurement principle requires the measured object to reflect a part of the incident radiation towards the source. The acquired measurement result is available at the analog current output and the RS 485 interface in parallel.</p> <p>Analog current output</p> <table border="0"> <tr> <td>Output current 4mA to 20mA:</td> <td>Valid measurement result</td> </tr> <tr> <td>Output current 3.5mA:</td> <td>No valid measurement could be achieved</td> </tr> <tr> <td>Output current 20.5mA:</td> <td>No object could be detected within range</td> </tr> </table> <p>Serial interface The RS 485 serial interface presents the measurement results, in the range from 0.05m to 30m, in a digital format. The interface is configured to 9600 baud, 8 data bits, 1 stop bit, no parity and no handshaking. Each result is presented as human readable ASCII string containing the measured distance in millimeters followed by carriage return and line feed characters (CR+LF).</p> <p>START input The measurement process is started by applying +24VDC at the START input. The device will stop to perform measurements if the START input is connected to 0V. For a longer lifetime of the laser, activate the sensor only when measurement is necessary.</p> | Output current 4mA to 20mA: | Valid measurement result | Output current 3.5mA: | No valid measurement could be achieved | Output current 20.5mA: | No object could be detected within range | <p>Maintenance and durability Urgent recommendation for longer lifetime of the laser: When no measurement is being made, disable the laser, by switching the DI-Input to 0V. For housing temperatures higher than 35°C, please refer to the document "Data sheets supplements". The sensor is maintenance-free. The measurement window must be cleaned carefully if soiled. Never use aggressive cleaning agents. Equipment must only be repaired or serviced by the manufacturer. The laser flashes in continuous measuring mode.</p> <p>Safety regulations for Laser devices class 2  Throughout the installation, the going into operation and the application, it is necessary to take into consideration the valid rule EN 60825-1. Do not stare into the beam!</p> <p>General safety informations The equipment is not used for the prevention of accidents. In worst case of disturbance, the output can show any state. The mounting, wiring, application and maintenance must be realized in accordance with the relevant rules and prescriptions. It is necessary to take into consideration the relevant international and national regulations.</p> <p>General notes, disposal We reserve the right to modify our equipment. Our equipment is designed such way, that it has the least possible adverse effect on the environment. It neither emit or contain any damaging or siliconized substances and use a minimum of energy and resources. No longer usable or irreparable units must be disposed of in accordance with the local waste disposal regulations.</p> <p>EU-Declaration of Conformity The product complies with the following standards and provisions: IEC 60079-0:2017, EN IEC 60079-0:2018, IEC/EN 60079-1:2014, IEC/EN 60079-28:2015, EN 60529:2014, EN 60950-1:2006, EN 61000-4-2 to EN 61000-4-6, EN 61000-6-1/-2, EN 61000-6-4, ATEX directive 2014/34/EU, Machine directive 2006/42/EC, EMC directive 2014/30/EU, RoHS directive 2011/65/EU</p> <p>ATEX certification: II 2(1)G Ex db [op is Ga] IIA T3 Gb. Certification No. BVS 10 ATEX E 130 X, IECEX BVS 14.0108X, ExCB: DEKRA Testing and Certification GmbH, Carl-Beyling-Haus, Dinendahlstrasse 9, D-44809 Bochum, Ident number: 0158.</p> <p>ATEX certification of quality management system, type production of Ex devices, in accordance to the directive 2014/34/EU, CE 0158. Certification No. BVS 18ATEX ZQS / E118, QAR No. DE/BVS/QAR13.0004/04. Mr. Pablo Ledergerber, Matrix Elektronik AG, is authorized to generation of documentation. The conformity of the devices with all used standards and directives and the EC-type examination certificate and the observation of the Quality Management System ISO 9001:2015 with the ATEX module "Production", declares:</p> |
| Output current 4mA to 20mA: | Valid measurement result | | | | | | |
| Output current 3.5mA: | No valid measurement could be achieved | | | | | | |
| Output current 20.5mA: | No object could be detected within range | | | | | | |