

In-Line Flow Meter Series 534FTB

The Kurz 534FTB is designed with built-in inlet and outlet piping reducers/expanders to produce exceptional immunity to upstream and downstream flow disturbances caused by elbows, valves, and line size changes.

The patented technology results in output with exceptional low end-to-end pressure drop and the fastest response to velocity and temperature changes in the industry.

The Kurz 534FTB in-line flow meter includes the qualities and features found in all Kurz constant temperature thermal flow meters that make them outperform all other currently available thermal mass flow meters, including:

- The highest repeatability, accuracy, and reliability available
- The fastest response to temperature and velocity changes in the industry
- Constant temperature thermal technology
- High turndown ratio
- Low flow noise
- Continuous self-monitoring electronics that verify the integrity of sensor wiring and measurements
- Sensors do not overheat at zero flow using a unique constant temperature control method and power limiting design
- Sensor lead length independent circuitry
- Sensor lead length independent circuitry
- Zero velocity as a valid data point
- Completely field configurable using the local user interface or via a computer connection
- Supports HART, Profibus DP, and Modbus communication protocols
- Velocity-temperature mapping for wide ranging velocity and temperature
- User-defined binary gas compositions or up to five multiple gas calibrations
- Flexibility with transmitter-attached or transmitter-separate designs
- Patented digital sensor control circuit (US 7,418,878)

Kurz Instruments is dedicated to manufacturing and marketing the best thermal mass flow meters available and to support our customers in their efforts to improve their businesses.

Applications

- Process & specialty gases
- Compressed air
- Fuel flow
- Natural gas metering
- Solvent & VOC recovery
- NOx control using ammonia
- Flow calibration
- Air sampling



intercontrol

Intercontrol

IJsselburcht 26
6825 BP Arnhem
Tel. +31 (0) 26 4425 204

info@intercontrol.eu



SPECIFICATIONS

- **Mass flow range**
Up to 7,016SCFM (10,944NCMH)
depending on model and calibration option
- **Flow accuracy**(SCFM at laboratory conditions)
 $\pm(1 + 2000 \times A/F)\%$
where F=SCFM, A=flow body area (ft²)
- **0.25% reading repeatability**
- **Velocity time constant**
1 second for velocity changes at
6,000SFPM (constant temp)
- **Process temperature time constant**
8 seconds for temperature changes at
6,000SFPM (constant velocity)
- **Temperature accuracy**
 $\pm(0.5\%$ of reading $+1^{\circ}\text{C}$) for
velocities above 100SFPM
- **Electronics operating temperature**
Integral display
-13°F to 149°F (-25°C to 65°C)
Remote aluminum display
-40°F to 149°F (-40°C to 65°C)
Remote polycarbonate display
-13°F to 122°F (-25°C to 50°C)

PROCESS CONDITIONS

- **Process pressure rating**
Up to 300PSIG (20 BARg)
- **Process temperature rating**
-40°F to 257°F (-40°C to 125°C)

APPROVALS

- **EPA mandatory GHG certification**
40 CFR 98.34(c)(1)
- **Alarm output conformity**
NAMUR NE43
- **European Union CE compliance**
EMC, LVD, PED, ROHS, and WEEE
- **Canadian Registration**
CRN
- **CSA, ATEX & IECEx approvals for Nonincendive, Flameproof, and Explosion-proof**
EN IEC 60079-0, EN IEC 60079-1
EN IEC 60079-15, CSA Class I, Div. 1 and 2

TRANSMITTER FEATURES

- **Aluminum (Type 4, IP66) dual chamber polyester powder-coated enclosure**
- **Adjustable display/keypad orientation**
- **Two optically-isolated 4–20mA outputs**
12-bit resolution and accuracy
Maximum loop resistance is
500Ω at 18 V DC, 800Ω at 24 V DC,
1400Ω at 36 V DC
- **Input power**
AC (85–264V 50/60 Hz, 24 watts max.)
or DC (24 V $\pm 10\%$), 1 A max.
- **Solid state relays**
Optically isolated,
0.5 A, 24 V AC/DC maximum
- **Integral or remote user interface**
Easy-to-use interface
Backlit display / keypad
2-lines of 16-characters each
- **User-configurable flow display (scrolling or static)**
- **User-configurable English or metric units for mass flow rate, mass velocity, and process temperature**
oC, oF, KGH, KGM, NCMH, NLPM, NMPS, PPD, PPH, PPM, SCFH, SCFM, SCM, SLPM
- **Two optically isolated solid-state relays /alarms**
Configurable as alarm outputs or pulsed totalizer output, or air purge cleaning
- **Built-in flow totalizers and elapsed time**
- **User-configurable digital filtering from 0 to 600 seconds**
- **Configuration/data access**
USB or RS-485 Modbus (ASCII or RTU)
- **Meter memory**
200 recent events, top 20 min/max, and
56 hours (10 second samples of trends)
- **3-year warranty**

SUPPORT & ELEMENT COMPONENTS

- **Sensor material**
C-276 alloy all-welded sensor construction
- **Sensor support**
316L stainless steel
- **Sensor flow body diameter options**
Available from 1/2" to 8"
- **Connection type**
Raised-face flange (Class 150 ANSI B16.5 or Class 30 ANSI B16.5) or male NPT pipe ends
- **3-year warranty**

OPTIONS

- **Enclosures**
Aluminum, stainless steel, or polycarbonate (remote only)
- **Multiple gas calibrations with up to five curves loaded in memory**
- **User-defined binary gas composition**
- **Communication protocols**
HART (v7 FSK) and PROFIBUS DP
- **One 4–20mA non-isolated analog input**
- **Digital input dedicated to zero-mid-span drift check**
- **Pulsed output as a remote flow totalizer**
- **Hardware accessories**
Available hardware includes sun shades, ball valves, cable glands, conduit seals, and cable





PROCESS TEMPERATURE & COMPENSATION

Temperature influences the physical properties of gases, so temperature compensation is required for a thermal sensor to accurately measure gas flow rates.

- **Standard Temperature Compensation (STC)** is used for process temperatures from 0°C to 125°C over a moderate velocity range.
- **Velocity Temperature Mapping (VTM)** is used when the process temperature and gas velocity vary widely. Multiple velocity calibrations are stored in the meter. VTM compensation is based on air; specific gas correlations are required to ensure accuracy at high temperatures.

The flow area (Fa) is the flow measurement section of the 534FTB, as shown in Parent Number table.

SPECIALTY GAS VELOCITY CALIBRATION

There are two types of gas calibration:

- **Laboratory gas calibrations** are performed with gases of high purity and are NIST traceable. Values above the calibrating facility limit are correlated up to the specified range. Customers must specify the calibration process pressure.
- **Correlation gas calibrations** are based on experimental data correlated to an Air calibration at ambient pressure and temperature. The flow element is calibrated in Air, and then an additional calibration data sheet is generated using the correlation factors. All correlation calibrations include velocity-temperature mapping.

Add $\pm 5\%$ of reading to the accuracy specification when using a correlation calibration.

For Oxygen gas, the customer is responsible for ensuring the mass flow sensor is clean of hydrocarbons and safe for Oxygen use.

ANALOG & DIGITAL INPUTS

All options include USB interface with ASCII text and Modbus protocol through RS-485.

The 4–20mA analog outputs (AO) are used for flow rate and/or temperature, or one AO for PID flow control. All AO are NAMUR NE-43 compliant.

Relay digital outputs (DO) can be alarms, EPA zero-mid-span drift is active, or pulsed totalizer function. PID uses one 4–20mA output for the flow controller. The EPA zero-mid-span drift check requires a contact closure to start the drift check. All 4–20mA outputs are used during the Drift Check Calibration process.

EPA zero-mid-span drift check can be initiated using digital inputs (DI), elapsed runtime automatic drift check, Modbus, or HART.

The 4–20mA analog input (AI) supports feedback to the device.



SERIES 534FTB OUTLINE DRAWINGS

DIRECTLY ATTACHED ELECTRONICS ENCLOSURE (TA)
 SHOWN WITH MODEL 534FTB-08B
 (SHOWN WITH DISPLAY IN STANDARD DISPLAY ORIENTATION)
 FEATURE 1, OPTIONS A & F (NOTE 3)

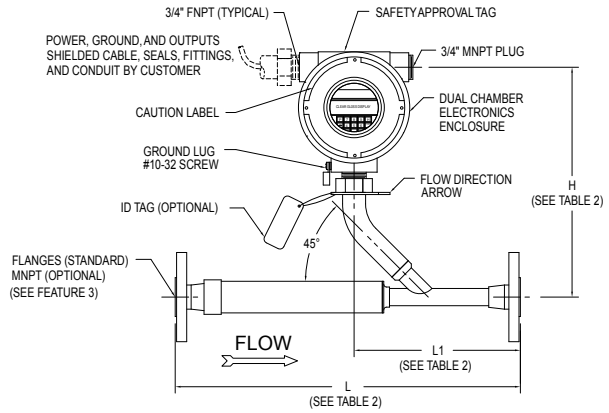

DIRECTLY ATTACHED ELECTRONICS ENCLOSURE (TA)
 SHOWN WITH MODEL 534FTB-32B, FEATURE 1, OPTIONS A & F
 (SHOWN WITH DISPLAY IN STANDARD DISPLAY ORIENTATION) (NOTE 3)

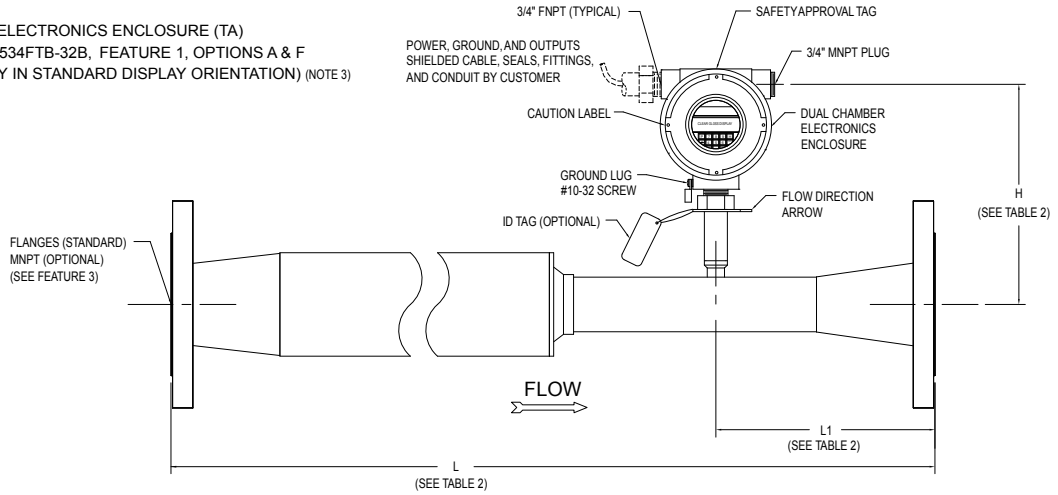

REMOTE ELECTRONICS ENCLOSURE
 SHOWN WITH MODEL 534FTB-32B
 FEATURE 1, OPTIONS D & I

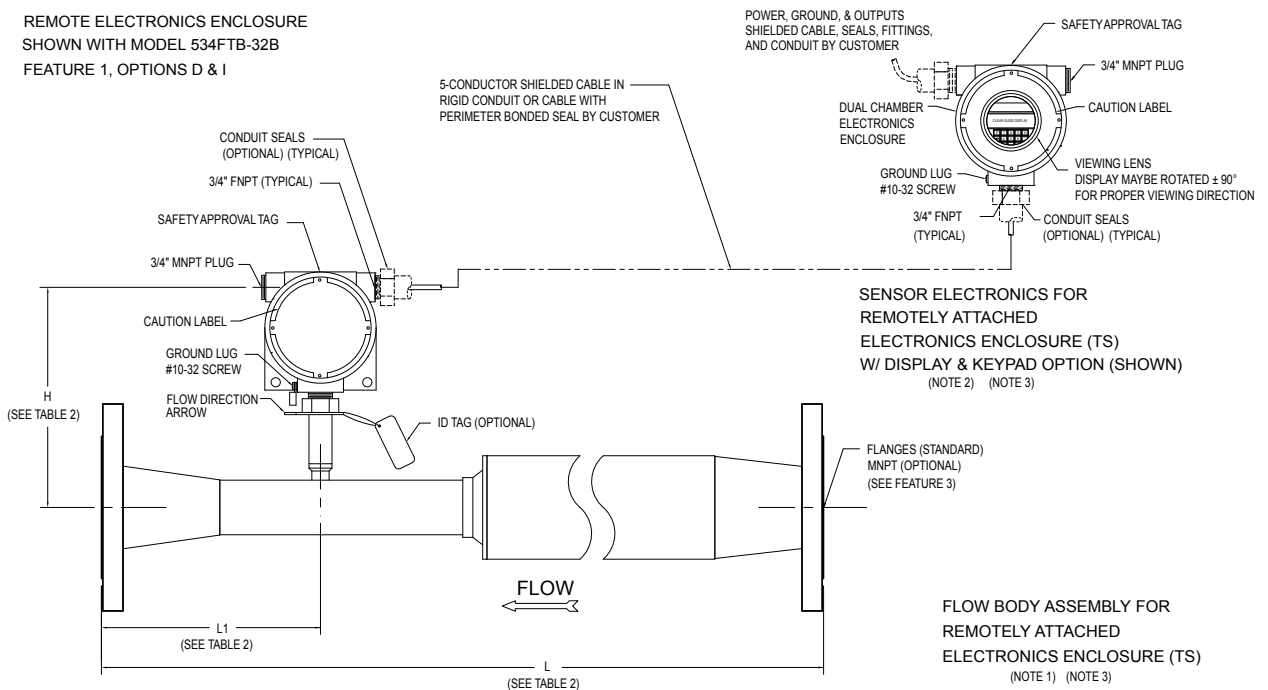



SERIES 534FTB OUTLINE DRAWINGS (cont'd)

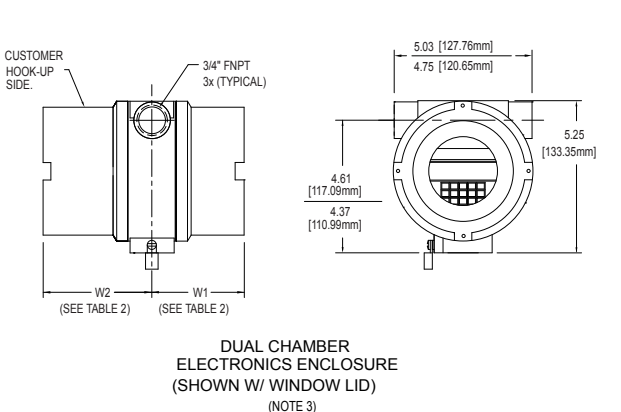
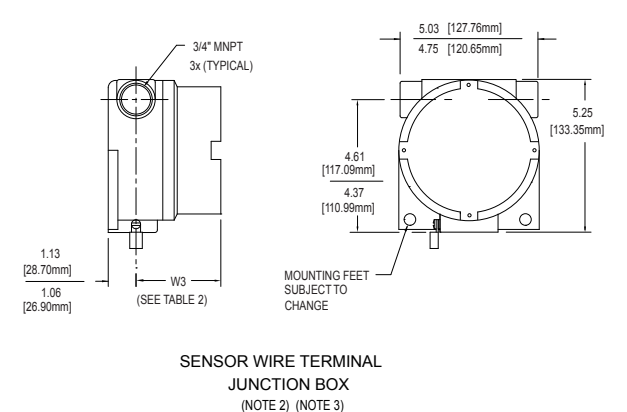
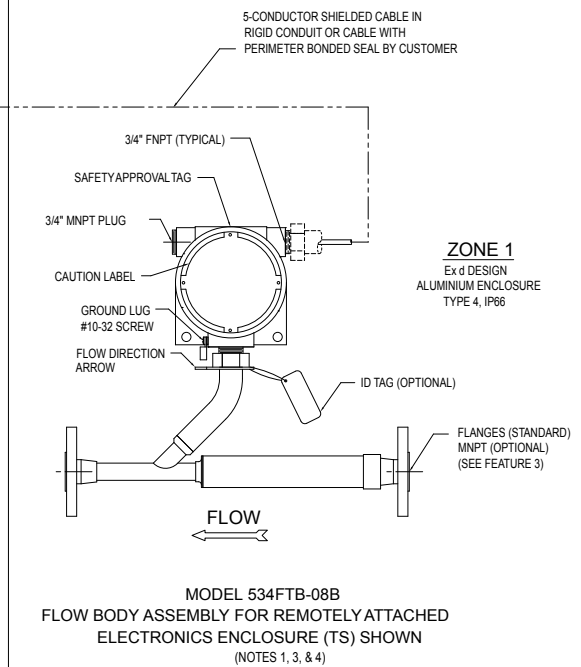
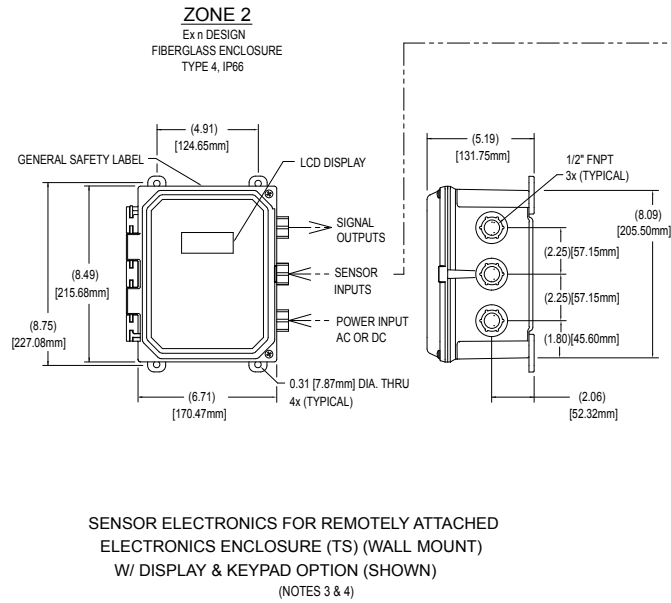



SERIES 534FTB OUTLINE DRAWINGS (cont'd)

TABLE 1 - ENCLOSURE DIMENSIONS (NOTE 3)

INPUT POWER	DISPLAY / KEYPAD	W1 (MAX.) (MIN.)	W2 (MAX.) (MIN.)	W3 (MAX.) (MIN.)
AC	YES	3.63 [92.20mm] 3.41 [86.61mm]	5.01 [127.25mm] 4.69 [119.13mm]	N/A
AC	NO	3.16 [80.26mm] 2.81 [71.37mm]	5.01 [127.25mm] 4.69 [119.13mm]	N/A
24VDC	YES	3.63 [92.20mm] 3.41 [86.61mm]	5.01 [127.25mm] 4.69 [119.13mm]	N/A
24VDC	NO (NOTE 4)	N/A	N/A	5.01 [127.25mm] 4.88 [123.95mm]
SENSOR WIRE TERMINAL J-BOX (FOR REMOTE OPT.)		N/A	N/A	3.16 [80.26mm] 2.81 [71.37mm]

TABLE 2 - SERIES 534FTB IN-LINE THERMAL MASS FLOW TRANSMITTER DIMENSIONS & WEIGHTS

MODEL NUMBER	NOMINAL PIPE SIZE (INCHES)	DIMENSIONS INCHES [mm] (NOTES 5 & 6)			NET WEIGHT (APPROX.) LBS. [kg] (NOTE 7)		
		(L)	(L1)	(H)	MNPT	CL150	CL300
534FTB-06A	1/2"	9.0 [228.6mm]	6.17 [228.6mm]	9.96 [253.0mm]	6.7 [3.04 kg]	8.2 [3.72 kg]	9.2 [4.17 kg]
534FTB-06B	3/4"	9.0 [228.6mm]	6.17 [228.6mm]	9.96 [253.0mm]	6.8 [3.08 kg]	9.1 [4.13 kg]	11.2 [5.08 kg]
534FTB-06C	1"	9.0 [228.6mm]	6.17 [228.6mm]	9.96 [253.0mm]	7.0 [3.17 kg]	10.1 [4.58 kg]	12.6 [5.71 kg]
534FTB-08A	1/2"	15.0 [381.0mm]	6.23 [158.2mm]	9.96 [253.0mm]	7.4 [3.36 kg]	8.9 [4.04 kg]	9.9 [10.35 kg]
534FTB-08B	3/4"	15.0 [381.0mm]	7.23 [183.6mm]	9.96 [253.0mm]	7.6 [3.45 kg]	9.9 [10.35 kg]	12.0 [5.44 kg]
534FTB-08C	1"	15.0 [381.0mm]	8.23 [209.0mm]	9.96 [253.0mm]	7.6 [3.45 kg]	10.7 [4.85 kg]	13.2 [5.99 kg]
534FTB-12A	3/4"	20.0 [508.0mm]	6.67 [169.4mm]	10.08 [256.0mm]	9.6 [4.35 kg]	11.9 [5.40 kg]	14.0 [6.35 kg]
534FTB-12B	1"	20.0 [508.0mm]	7.54 [191.5mm]	10.08 [256.0mm]	9.3 [4.22 kg]	12.4 [5.62 kg]	14.9 [6.76 kg]
534FTB-12C	1-1/2"	20.0 [508.0mm]	9.98 [253.5mm]	10.08 [256.0mm]	9.9 [4.49 kg]	15.0 [6.80 kg]	20.0 [9.07 kg]
534FTB-16A	1"	26.0 [660.4mm]	7.48 [190.0mm]	10.21 [259.3mm]	11.9 [5.40 kg]	15.0 [6.80 kg]	17.5 [7.94 kg]
534FTB-16B	1-1/2"	26.0 [660.4mm]	9.79 [248.7mm]	10.21 [259.3mm]	11.8 [5.35 kg]	16.9 [7.66 kg]	21.9 [9.93 kg]
534FTB-16C	2"	26.0 [660.4mm]	11.67 [296.4mm]	10.21 [259.3mm]	12.5 [5.67 kg]	20.5 [9.30 kg]	23.6 [10.70 kg]
534FTB-24A	1-1/2"	38.0 [965.2mm]	4.00 [101.6mm]	9.28 [235.7mm]	18.5 [8.39 kg]	23.6 [10.70 kg]	28.6 [12.97 kg]
534FTB-24B	2"	38.0 [965.2mm]	5.96 [151.4mm]	9.28 [235.7mm]	18.8 [8.53 kg]	26.8 [12.15 kg]	29.9 [13.56 kg]
534FTB-24C	3"	38.0 [965.2mm]	10.75 [273.1mm]	9.28 [235.7mm]	N/A	35.2 [15.96 kg]	42.6 [19.31 kg]
534FTB-32A	2"	48.0 [1219.2mm]	4.87 [121.4mm]	9.54 [242.3mm]	26.6 [12.06 kg]	34.6 [15.69 kg]	37.7 [17.09 kg]
534FTB-32B	3"	48.0 [1219.2mm]	9.52 [241.8mm]	9.54 [242.3mm]	N/A	42.9 [19.46 kg]	50.3 [22.81 kg]
534FTB-32C	4"	48.0 [1219.2mm]	13.68 [347.5mm]	9.54 [242.3mm]	N/A	49.0 [22.22 kg]	66.7 [30.25 kg]
534FTB-48A	3"	72.0 [1828.8mm]	7.18 [182.4mm]	13.18 [334.8mm]	N/A	72.4 [32.83 kg]	N/A
534FTB-48B	4"	72.0 [1828.8mm]	11.24 [285.5mm]	13.18 [334.8mm]	N/A	78.6 [35.65 kg]	N/A
534FTB-48C	6"	72.0 [1828.8mm]	20.00 [50.8mm]	13.18 [334.8mm]	N/A	87.5 [39.68 kg]	N/A
534FTB-64A	4"	94.0 [2387.6mm]	9.18 [233.2mm]	13.18 [334.8mm]	N/A	122.6 [55.60 kg]	N/A
534FTB-64B	6"	94.0 [2387.6mm]	17.82 [452.6mm]	13.18 [334.8mm]	N/A	131.4 [59.60 kg]	N/A
534FTB-64C	8"	94.0 [2387.6mm]	26.12 [663.4mm]	13.18 [334.8mm]	N/A	151.9 [68.89 kg]	N/A

NOTES:

- 1) THIS PROBE CONFIGURATION ALSO USED FOR DIRECTLY ATTACHED, DC POWERED, NO DISPLAY.
- 2) SENSOR WIRE TERMINAL JUNCTION BOX USED FOR SENSOR ELECTRONICS FOR DC POWERED, NO DISPLAY.
- 3) ENCLOSURE STYLES AND DIMENSIONS ARE SUBJECT TO CHANGE.
- 4) THIS CONFIGURATION ALLOWS FOR PROBE ASSEMBLY TO BE MOUNTED IN ZONE 1 AREA AND FOR REMOTE ELECTRONICS TO BE MOUNTED IN ZONE 2 AREA.
- 5) L DIMENSION IS OVERALL END TO END.
- 6) ADD 3.00 [76.2mm] TO L AND L1 DIMENSIONS FOR MNPT OPTION.
- 7) WEIGHTS SHOWN ARE FOR DIRECTLY ATTACHED, AC POWER, WITH DISPLAY. FOR REMOTELY ATTACHED VERSIONS ADD 4.0 LBS. [1.82 kg].



STANDARD FULL-SCALE FLOW RATES

Table A: Standard Full-Scale Flow Rate Ranges (Qmax)

Model Number	Flow Area (ft ²)	Laboratory ¹ Calibration Range		Correlated ² Calibration Range	
		SCFM	NCMH	SCFM	NCMH
534FTB-06	0.00045	8.1	12.6	10.8	16.8
534FTB-08	0.00158	28	44	37.2	58.5
534FTB-12	0.00341	61	95	81.1	126.4
534FTB-16	0.00590	106	165	141	219.5
534FTB-24	0.01466	264	412	351.1	548
534FTB-32	0.02454	442	690	587.9	917.7
534FTB-48	0.05642	1016	1585	1351.3	2108
534FTB-64	0.09743	1754	2736	2332.8	3638.9

Note: 1. The baseline maximum flow rate for each transmitter model number.
2. Compressed air only.

SCFM Standard Cubic Feet Per Minute, Reference: 77°F, 14.69PSIA

NCMH Normal Cubic Meters Per Hour, Reference 0°C, 760 mmHg
NCMH = 1.56 x SCFM (approximate)

ESTIMATED PRESSURE DROP

To compute the expected pressure drop for a flow rate, multiply the full scale pressure drop by the square of the flow ratio.

Table B: Estimated Pressure Drop (DPs)

Gas Type	Inches H ₂ O	mm H ₂ O	kPa
Air	7.5	191	1.86
Argon	10.3	263	2.56
Butane	15.1	382	3.73
Carbon Dioxide	11.4	289	2.83
Dry Ammonia	4.4	112	1.09
Dry Chlorine	18.4	466	4.55
Ethane	7.8	198	1.93
Ethylene	7.3	185	1.80
Helium	1.0	26	0.26
Hydrogen	0.5	13	0.13
Methane	4.2	106	1.03
Digester Gas: 50% CH ₄ , 50% CO ₂	7.8	198	1.93
Digester Gas: 60% CH ₄ , 40% CO ₂	7.1	179	1.75
Digester Gas: 70% CH ₄ , 30% CO ₂	6.3	161	1.57
Nitrogen	7.3	184	1.80
Oxygen	8.3	210	2.06
Propane	11.4	290	2.83

Note: Estimated pressure drop (DPs) is the end-to-end pressure drop at standard conditions at the baseline flow rate in Table A.



755 _ _ _
Parent number

F1

F2

F3

F4

F5

F6

F7

F8

F9

F10

Parent Number	Model	Inlet / Outlet Pipe Size	Length
755438	534FTB-06A	0.5" (13 mm)	9" (229 mm)
755439	534FTB-06B	0.75" (19 mm)	9" (229 mm)
755440	534FTB-06c	1" (25 mm)	9" (229 mm)
755441	534FTB-08A	0.5" (13mm)	15" (381 mm)
755442	534FTB-08B	0.75" (19 mm)	15" (381 mm)
755443	534FTB-08C	1" (25 mm)	15" (381 mm)
755444	534FTB-12A	0.75" (19 mm)	20" (508 mm)
755445	534FTB-12B	1" (25 mm)	20" (508 mm)
755446	534FTB-12C	1.5" (38 mm)	20" (508 mm)
755447	534FTB-16A	1" (25 mm)	26" (660 mm)
755448	534FTB-16B	1.5" (38 mm)	26" (660 mm)
755449	534FTB-16C	2" (51 mm)	26" (660 mm)
755450	534FTB-24A	1.5" (38 mm)	38" (965 mm)
755451	534FTB-24B	2" (51 mm)	38" (965 mm)
755452	534FTB-24C	3" (76 mm)	38" (965 mm)
755453	534FTB-32A	2" (51 mm)	48" (1219 mm)
755454	534FTB-32B	3" (76 mm)	48" (1219 mm)
755455	534FTB-32C	4" (102 mm)	48" (1219 mm)
755459	534FTB-48A	3" (76 mm)	72" (1829 mm)
755460	534FTB-48B	4" (102 mm)	72" (1829 mm)
755461	534FTB-48C	6" (152 mm)	72" (1829 mm)
755462	534FTB-64A	4" (102 mm)	94" (2388 mm)
755463	534FTB-64B	6" (152 mm)	94" (2388 mm)
755464	534FTB-64C	8" (203 mm)	94" (2388 mm)

Note: Model lengths from 9" to 48" use the MD sensor type.
Model lengths 72" and 94" use the FD2 sensor type.

F1	Option	Electronics Enclosure Configuration and Input Power
	A	Directly attached dual-chamber electronics enclosure, AC/DC power, display / keypad
	B	Directly attached dual-chamber electronics enclosure, AC/DC power, without display / keypad
	C	Directly attached dual-chamber electronics enclosure rotated 180° for viewing, AC/DC power, display / keypad
	D	Remote dual-chamber electronics enclosure, AC/DC power, display / keypad
	E	Remote dual-chamber electronics enclosure, AC/DC power, without display / keypad
	F	Directly attached dual-chamber electronics enclosure, DC power, display / keypad
	G	Directly attached dual-chamber electronics enclosure rotated 180° for viewing, DC power, display / keypad
	H	Directly attached single-chamber electronics enclosure, DC power, without display / keypad
	I	Remote dual-chamber electronics enclosure, DC power, display / keypad
	J	Remote single-chamber electronics enclosure, DC power, without display / keypad
	R	Remote polycarbonate electronics enclosure, AC/DC power, with display / keypad
	S	Remote polycarbonate electronics enclosure, AC/DC power, without display / keypad
	V	Stainless steel sensor and electronics enclosures, AC power, with display / keypad
	W	Stainless steel sensor and electronics enclosures, AC power, without display / keypad
	X	Stainless steel sensor and electronics enclosures, DC power, with display / keypad
	Y	Stainless steel sensor and electronics enclosures, DC power, without display / keypad

F2	Sensor & Flow Body Material	
	Choose one option from each category.	
	Option	Sensor Material (first digit)
	3	C-276 alloy
	Option	Flow Body Material (second digit)
	2	316L stainless steel

F3	Option	Flow Body Connection Type & Pressure Rating
	A	Male NPT pipe ends (MNPT) 300 PSIG
	B	Class 150 ANSI B16.5 flanges (CL150) 150 PSIG
	C	Class 300 ANSI B16.5 flanges (CL300) 300 PSIG

F4	Option	Process Temperature Compensation
	1	Standard temperature compensation over process range of -40°C to 125°C for all gases. Accuracy: ±(1 + 2000 x A/F) %, where F = SCFM, A = flow body area (ft²)

Note: An accuracy specification of ±0.025%/°C = (A*)/(0.25 SFPM/°C) should be added for temperatures above or below standard.

more on next page



F5	Gas Flow Rate Calibration Data Range			
	Option	Description	Option	Description
	A	100% Qmax	I	60% Qmax
	B	95% Qmax	J	55% Qmax
	C	90% Qmax	K	50% Qmax
	D	85% Qmax	L	45% Qmax
	E	80% Qmax	M	40% Qmax
	F	75% Qmax	N	35% Qmax
	G	70% Qmax	P	30% Qmax
	H	65% Qmax	Q	25% Qmax
Note: Refer to Tables A and B to determine the correct selection for calibration range selection.				

F6	Specialty Gas Velocity Calibration		
	Laboratory Calibration	Correlation Calibration	Description
	010	-	Ambient Air
	070	-	Compressed Air
	-	0K0	Compressed Air (correlated to 4x baseline flow rate)
	-	560	Dry Ammonia
	080	580	Argon
	-	600	Butane
	140	640	Carbon Dioxide
	-	680	Dry Chlorine
	200	700	Ethane
	220	720	Ethylene
	260	760	Helium
	280	-	Hydrogen
	320	820	Methane
	350	850	Digester Gas 50% CH ₄ 50% CO ₂
	360	860	Digester Gas 60% CH ₄ 40% CO ₂
	370	870	Digester Gas 70% CH ₄ 30% CO ₂
	-	8K0	User-Defined Binary Gas Composition
	-	8M0	One Gas Curve
	-	8N0	Two Gas Curves
	-	8O0	Three Gas Curves
	-	8P0	Four Gas Curves
	-	8Q0	Five Gas Curves
	400	900	Nitrogen
	440	940	Oxygen
	460	960	Propane
Notes: Laboratory gas calibrations are performed with high purity gases and are NIST Traceable. Customers must specify process pressure (Feature 8). Propane to 50PSIA, all other gases to 150PSIA. Options 8M0-8Q0 allow up to a 5-gasmix per curve; contact KurzSales Support if Hydrogen is included in the mix.			

F7	Option	Safety Approvals
	A	Non-Incendive, CSA, ATEX, and IECEx Aluminum enclosure Type 4, IP66 ExnA IICTx; ExnA IICTxGc; Class I Zone 2 AExnA IICTxGc Sensing element, T _p : -40°C to 55°C: T5 or to 130°C: T3 DC power electronics housing, T _a : -40°C to 65°C: T4 AC power electronics housing, T _a : -40°C to 50°C: T4 or to 65°C: T150°C CSA Approved for Class I, Division 2, Groups B, C, D
	B	Explosion-Proof/Flame-Proof, CSA, ATEX, and IECEx Aluminum enclosure Type 4, IP66 Exd IIB +H ₂ Tx; Exd IIB +H ₂ Tx Gb; Class I Zone 1 AExd IIB +H ₂ Tx Gb Sensing element, T _p : -40°C to 45°C: T4 or to 110°C: T3 DC power electronics housing, T _a : -40°C to 65°C: T4 AC power electronics housing, T _a : -40°C to 50°C: T4 or to 65°C: T150°C (T3) CSA Approved for Class I, Division 1, Groups B, C, D
	D	Transmitter and sensing element separate Sensor enclosure: Aluminum Type 4, IP66 Electronics enclosure: Polycarbonate Type 4, IP54 (Feature 1, Option R or S) Sensing element: Exd IIB +H ₂ Tx; Exd IIB +H ₂ Tx Gb; Class I Zone 1 AExd IIB +H ₂ Tx Gb, T _p : -40°C to 45°C: T4 or to 110°C: T3 AC power electronics housing: ExnA IICTx; ExnA IICTxGc; Class I Zone 2 AExnA IICTxGc, T _a : -25°C to 50°C: T4 Sensing element: CSA Approved for Class I, Division 1, Groups B, C, D Electronics housing: CSA Approved for Class I, Division 2, Groups B, C, D
	H	Remote — Transmitter and sensing element separate Sensor enclosure: Stainless Steel Type 4X, IP66 Electronics enclosure: Stainless Steel Type 4X, IP66 Explosion-Proof/Flame-Proof sensor: CSA, ATEX, and IECEx Exd IIB +H ₂ Tx; Exd IIB +H ₂ Tx Gb; Class I Zone 1 AExd IIB +H ₂ Tx Gb Sensing element, T _p : -40°C to 45°C: T4 or to 110°C: T3 DC power electronics housing, T _a : -40°C to 65°C: T4 AC power electronics housing, T _a : -40°C to 50°C: T4 or to 65°C: T150°C (T3) CSA Approved for Class I, Division 1, Groups B, C, D

F8	Option	Process Pressure
	---	Enter the Absolute Pressure (PSIA) rounded to 3 digits. For example, a process Absolute Pressure of 14.7PSIA, round to 15.0 and enter 015; for 150PSIA enter 150.

F9	Option	Communications and Inputs/Outputs
	B	Standard Two 4-20mA isolated outputs
	C	Full Two 4-20mA isolated outputs, two relays, two digital inputs, one non-isolated 4-20mA input
	E	HART-1 One 4-20mA isolated output, two relays, two digital inputs, one non-isolated 4-20mA input
	H	HART-2 Two 4-20mA isolated outputs, two relays, two digital inputs, one non-isolated 4-20mA input
	K	Profibus DP Two 4-20mA isolated outputs, two relays, two digital inputs, one non-isolated 4-20mA input

F10	Option	Process Temperature
	---	Enter the Absolute Temperature (°Rankin = °F + 460) rounded to 3 digits. For example, a Process Temperature of 77°F is written as 537(77 + 460).