



## INTRODUCTION

ViSCO.mini® has been designed for precise dosing of fluids and pastes and is especially suitable for abrasive fluids. ViSCO.mini® is suitable for a wide range of applications for high- and low viscous fluids.

## PRINCIPLE

The technology of the newly developed ViSCO.mini® is based on the volumetric principle of an endless piston whereas the core components rotor and stator form a perfectly sealed metering chamber. The eccentric movement of the rotor allows for a low shear motion of the fluid from one chamber to the next chamber without squeezing the fluid.

## VERSIONS

The ViSCO.mini® is available with different material combinations, always optimized and based on the application. Housing available standard in aluminium, on request available in stainless steel, stator in FKM or FFKM, depending on application requirements, rotor in stainless steel, sealed with a triple radial shaft seal. Rotor can be provided with a wear resistant coat.

## ADVANTAGES

- Continuous volumetric dosing
- Valveless closed system
- Independent of viscosity
- Low pulsation and shear
- High dosing accuracy
- High repeatability
- Handles abrasive media
- Suck back effect

## TYPICAL APPLICATIONS

- Glue dispensing
- Coating of printed circuit boards
- Bead dispensing
- Underfillings
- Dosing of filling compounds
- Dosing of highly viscous, abrasive and corrosive fluids

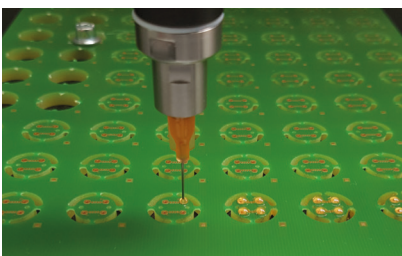

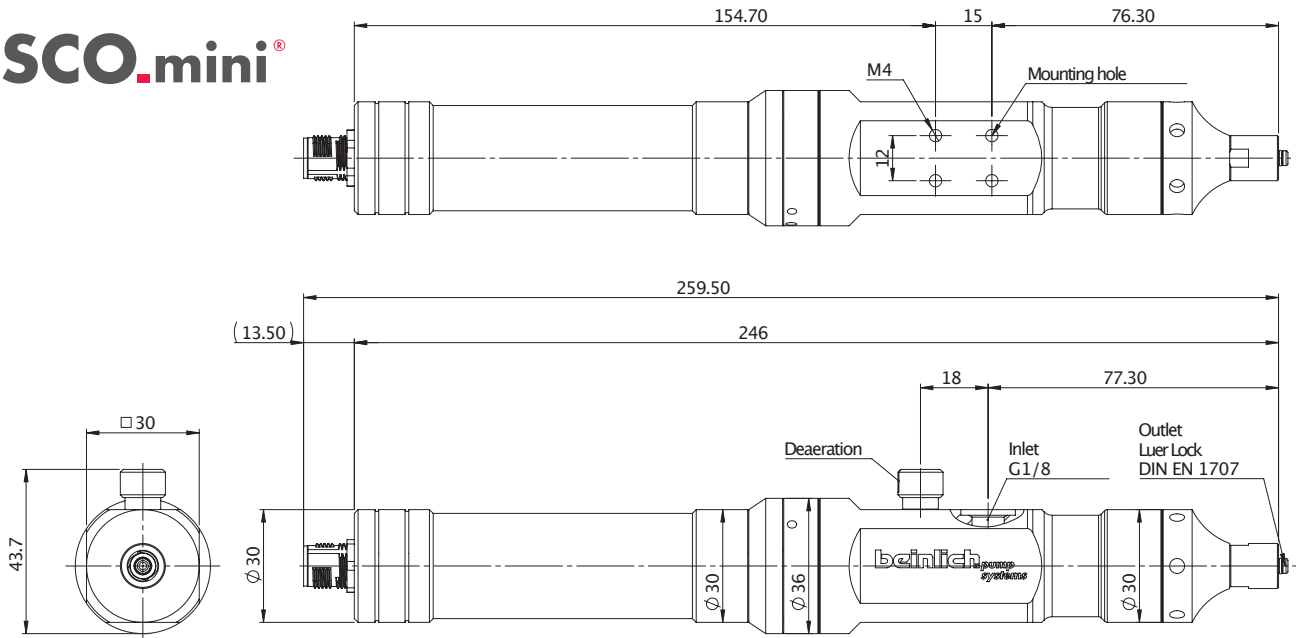

## TECHNICAL DETAILS

Nominal Size	0.01
Type Key	VPN 1-0,01-BE-L-M/HSO/P2-000
Material inlet	G 1/8"
Material outlet	Luer lock DIN EN 1707 with O-ring
Minimum operating pressure (inlet)	0 bar, self-leveling liquid
Maximum operating pressure (inlet)	0 to 6 bar input pressure, non-self-leveling liquid
Maximum operating pressure (outlet)	10 bar
Wetted parts material	Aluminium/ stainless steel, FFKM (perfluorelastomer), PTFE shaft seal
Motor	24 V DC incremental encoder, planetary gears
Operating conditions	+10°C to +40°C, air pressure 1 bar
Fluid temperature	+10°C to +40°C
Approx. dispensing volume per revolution	0.013 ml
Accuracy of dispensing	+/-1 %
Rotating speed	0 to 150 rpm
Flow rate*	0.13 to 1.95 ml/min
Minimum dispensing volume	0.002 ml
Starting torque	0.22 Nm
Recommended drive current limit	1.4 A
Self-tightness**	4 bar (reference fluid approx. 10 mPas at 23°C)
Storage conditions***	dry & dust-free, -10°C to +40°C
Weight	approx. 450 gram

\*\*\* stator must be separated from rotor in case of longer storage

\*\* indicated max. tightness pressure can decrease depending on lower fluid viscosity

\* flow rate based on 10 to 150 rpm on viscosity 63 mPas and primary pressure