

A Higher Level of Performance



Data Sheet

# Centurion Guided Radar



[www.hawkmeasurement.com](http://www.hawkmeasurement.com)

 **intercontrol**

**Intercontrol**

IJsselburcht 26  
6825 BP Arnhem  
Tel. +31 (0) 26 4425 204

[info@intercontrol.eu](mailto:info@intercontrol.eu)

# Overview

## Centurion Guided Radar



### Description

The Centurion Guided Radar (CGR) Level Transmitter is ideal for the measurement of liquids, sludge, powders and granules to a range of 38m (124ft) for level and interface measurement. This award-winning technology is not affected by pressure, temperature, viscosity, vacuum, foam, dust, changes in dielectric constant or coating of the probe. HAWK's CGR won the prestigious Chemical Processing 2021 Vaaleer Awards.

HAWK's CGR is the first and only guided wave radar on the market to feature Power over Ethernet (PoE) communications. The advantages to PoE connectivity are secure in-plant and remote monitoring, as well as remote sensor setup, diagnostics and troubleshooting abilities.

### Principle of Operation

Guided-wave technology sends the radar pulse down a probe to measure either liquids, solids or a low dielectric to high dielectric Interface level.

The pulse hits the surface and / or Interface and is reflected back up the probe to the sensor, where the transit time is translated into a distance using time of flight and time expansion. The amplitude of the reflection depends on the dielectric constant of the product.

### Primary Areas of Application

- Chemicals
- Petrochemicals
- Cement
- Building Aggregates
- Mining / Minerals
- Food & Beverages
- Oil & Gas
- Pharmaceutical
- Pulp & Paper
- Wastewater



### Features

- Hazardous rated for Gas & Dust with IECEx, FM, CSA & ATEX
- Safety Rated to SIL2, SIL3 (multi channel)
- First Powered Ethernet (PoE) Enabled GWR in the Industry
- Interface Level measurement option
- Up to 38m (124ft) range
- Very short minimum range ( $\leq 150\text{mm}$ , 6")
- Simple setup
- Auto-calibration to any dielectric  $\geq 1.5$
- Automatic Sensitivity Control
- Precise & continuous measurement
- 4-20mA with HART 7
- Protection class IP66, NEMA 4x
- Measures extremely low dielectric (1.5)
- Programmable fail safe mode

# Overview

## Centurion Guided Radar



### Power over Ethernet (PoE) Communication

Hawk Measurement (HAWK) created the industry's first and only Guided Wave Radar level transmitter that features Power over Ethernet (PoE) communications. The advantages to PoE connectivity are secure in-plant and remote monitoring, as well as remote sensor setup, diagnostics and troubleshooting abilities. The Centurion Guided Radar (CGR) Level Transmitter is ideal for the measurement of liquids, sludge, powders and granules to a range of 38m (124ft) for level and interface measurement.

If troubleshooting is required, the CGR PoE will communicate to remote service technicians for off-site diagnostics, sensor health and re-configuration, without the need to climb a tank or enter the facility. HAWK's CGR PoE can connect to an online portal, the HawkEye365, which can monitor multiple tanks worldwide in real-time. The portal provides accessibility to critical data such as the ability to view volume, space, material height, historical trending, alarms and alerts, sensor setup and diagnostics. Plant level operator screens are customized to the company's specifications to include control room level and operations level interface screens. The graphical user interface will be common throughout and permissions can be set for different tiers such as plant-level, finance, or executive level.

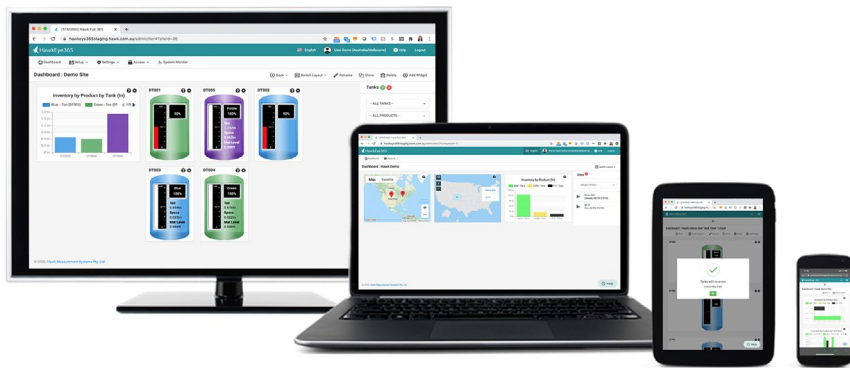
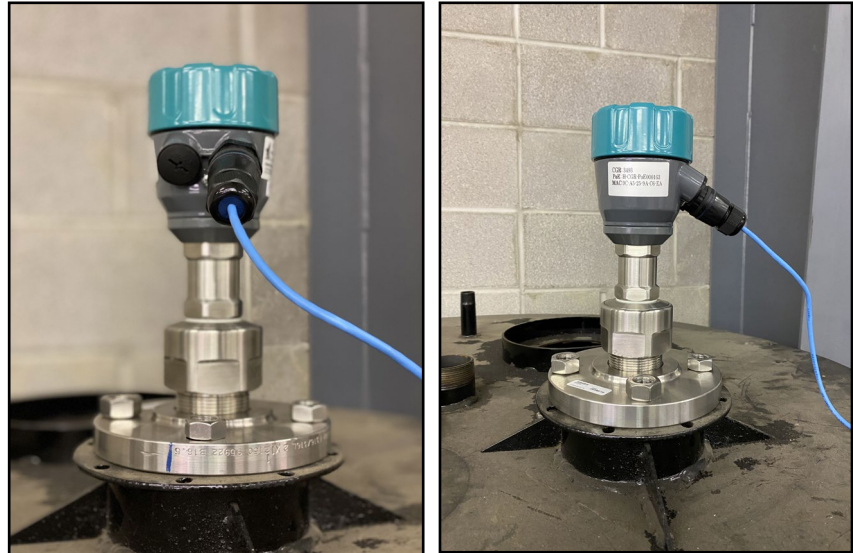

### PoE Features

- Remotely monitor tank levels from smart phone, tablet, or computer
- Real-time tank monitoring from online portal
- Receive tank alarms and alerts to phone and email
- Secure in-plant and remote monitoring
- Remote sensor setup
- Remote diagnostics and troubleshooting abilities

### Awards





### HART Units

Dual Chamber

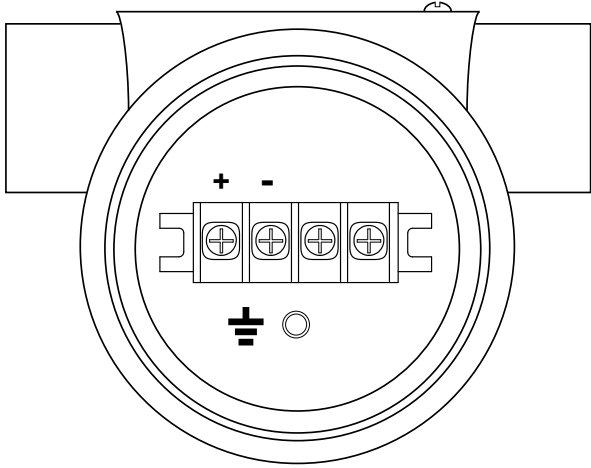

Single Chamber

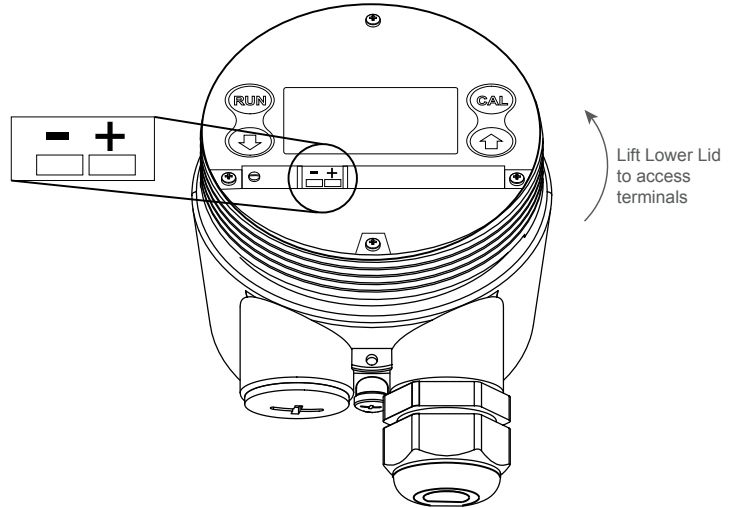

### Modbus / Ethernet Units

Dual Chamber

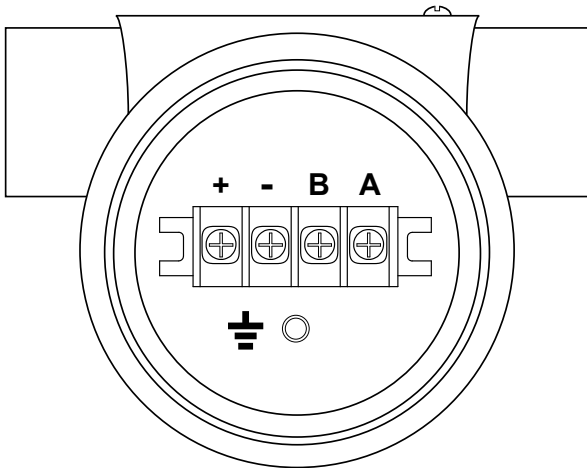

Single Chamber

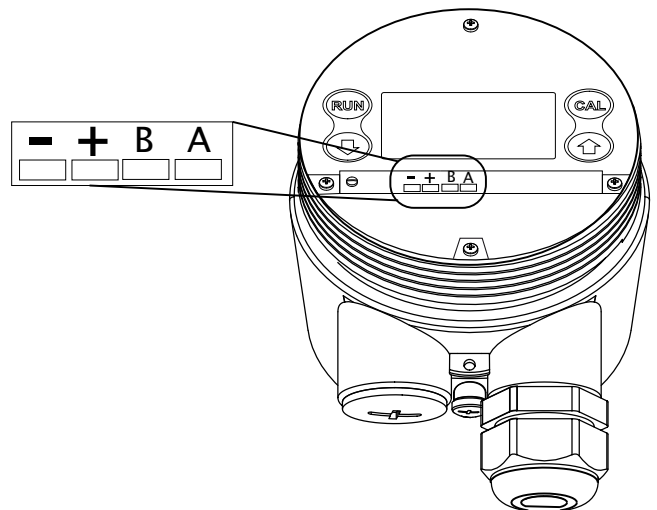



### Dimensions - Housing

#### Dual Chamber

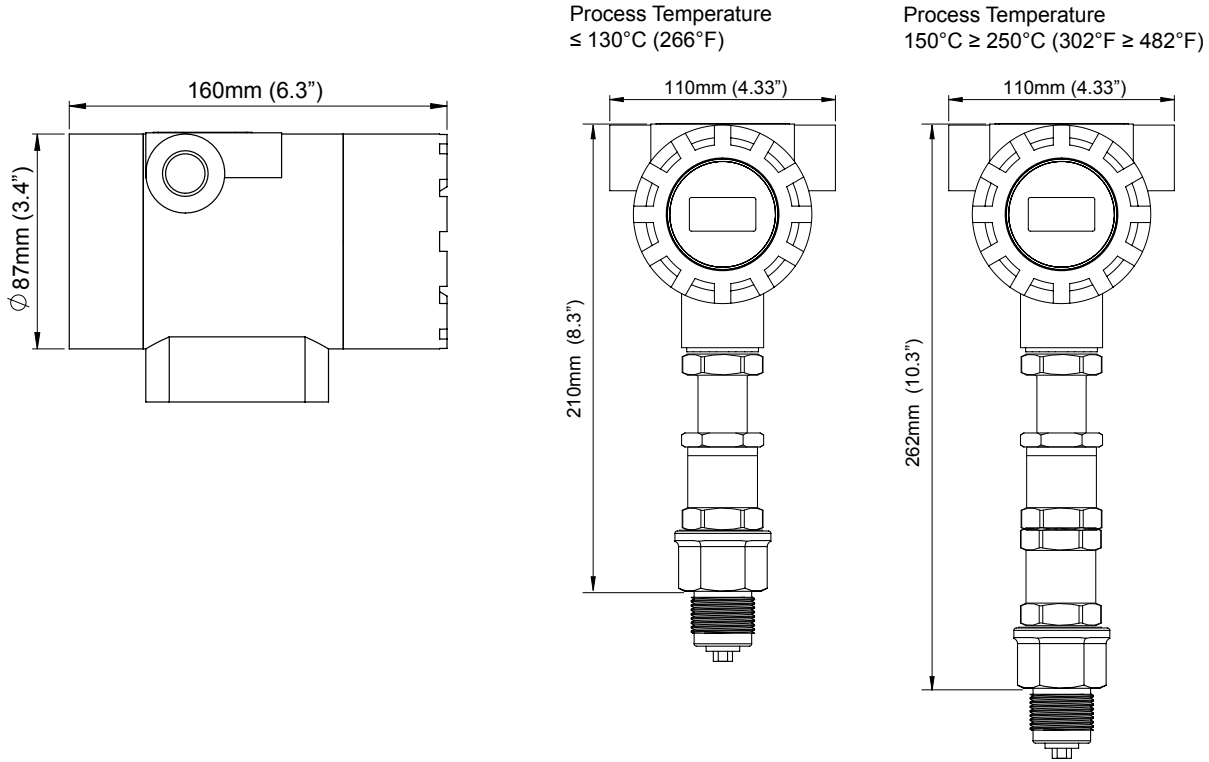

#### Single Chamber with Viewing Window

Process Temperature  
 $80^\circ\text{C}$  (176°F)

Process Temperature  
 $130^\circ\text{C} \geq 250^\circ\text{C}$  (266°F  $\geq$  482°F)

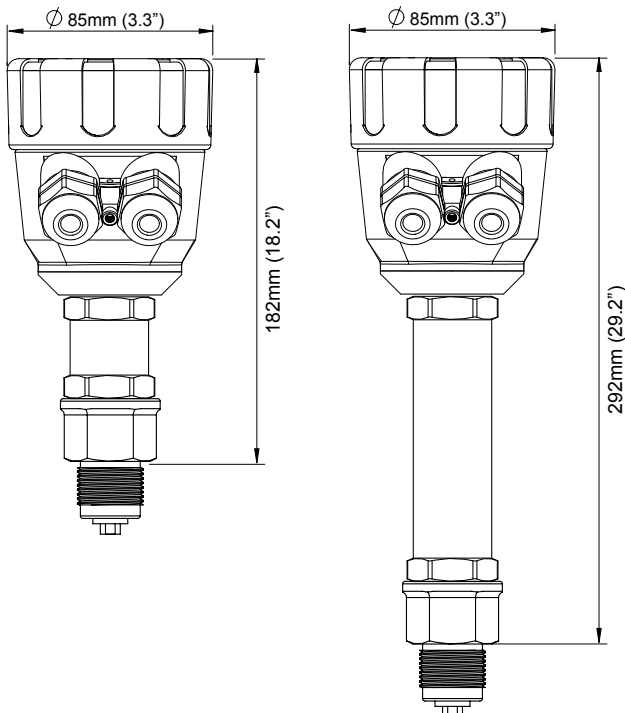

#### Single Chamber with no Viewing Window

Process Temperature  
 $80^\circ\text{C}$  (176°F)

Process Temperature  
 $130^\circ\text{C} \geq 250^\circ\text{C}$  (266°F  $\geq$  482°F)

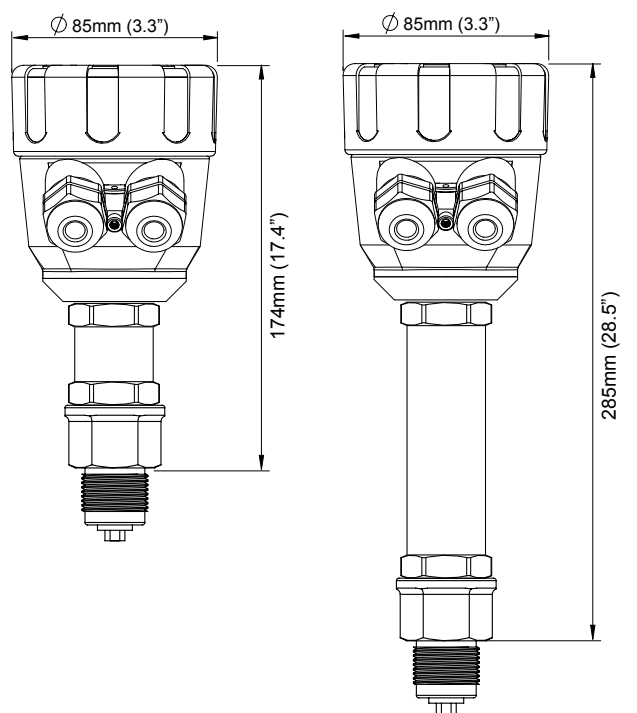



## Dimensions - Probe Variants

### A04 / A06 / A08 / J04 / J06 / J08

### B04 / B06 / B08 / K04 / K06 / K08 / B11

#### Threaded

#### Integrated Flange

#### Threaded

#### Integrated Flange

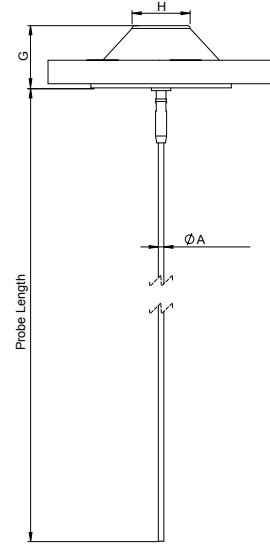
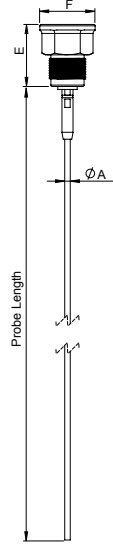
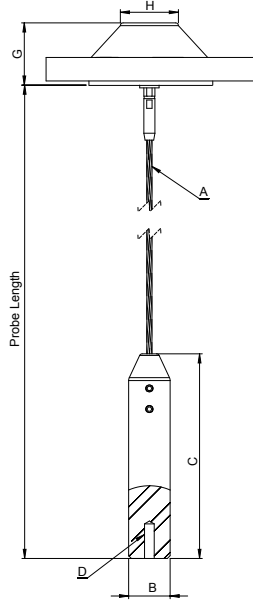
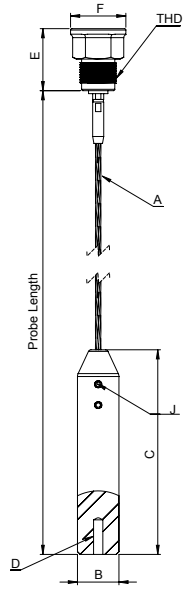

Probe / Cable Dimensions

Probe Type	THD BSP or NPT	A		B		C		E		F		D Internal Threads (A04, A06, A08 only)	J (Tightening Torque = 20Nm)		
	in.	mm	in.	mm	in.	mm	in.	mm	in.	mm	in.		Set Screw	Hex Key Size	
A04, B04, J04, K04	3/4	4	0.16	22	0.9	120	4.7	45	1.8	40	1.6	M10x1.25, 24mm deep	3x M8x1.25x12	4mm	
A06, B06, J04, K04	1	6	0.24	28	1.1	150	5.9	45	1.8	40	1.6	M10x1.25, 24mm deep	3x M8x1.25x12	4mm	
B11	1	6	0.43	NA	NA	NA	NA	NA	NA	40	1.6	NA	NA	NA	
A08, B08, J04, K04	1-1/2	8	0.31	36	1.4	200	7.8	72	2.8	64	2.5	M10x1.25, 24mm deep	3x M10x1.5x18	5mm	
	Integrated Flange	G		H											
		mm	in.	mm	in.										
A04, B04, J04, K04, A06, B06, J06, K06, B11		45	1.8	42	1.6										
A08, B08, J04, K04		72	2.8	70	2.7										



### Centurion Guided Radar System

#### 3/4" & 1" Threaded Units (mounting option TN07, TB07, TN10, TB10, Flanged)

##### Model

- CGR2 2 wire Centurion Guided Radar
- CGR4 4 wire Centurion Guided Radar

##### Communication

- H 4-20mA with HART 7<sup>6</sup>
- I 4-20mA with HART 7 and Interface Level<sup>6</sup>
- L 4-20mA with HART 7 and SIL2<sup>6</sup>
- W Modbus with Interface Level<sup>7</sup>
- E Modbus over PoE (Powered Ethernet). HawkEye365 compatible<sup>7,8</sup>

##### Housing

- |  |  |
|--|--|
| 1 Dual Chamber Aluminium, epoxy painted with viewing window            | A Single Chamber Aluminium, powder coated with viewing window <sup>4</sup> |
| 2 Dual Chamber 316L Stainless Steel, with viewing window               | B Single Chamber Aluminium, powder coated, no viewing window <sup>4</sup>  |
| C Single Chamber 316L Stainless Steel with viewing window <sup>4</sup> | D Single Chamber 316L Stainless Steel with no viewing window <sup>4</sup>  |

##### Conduit / Cable Entry

- 1 1/2" NPT
- 3 M20 x 1.5

##### Probe Type

- A04 4mm flexible cable
- A06 6mm flexible cable
- B04 4mm rigid probe
- B06 6mm rigid probe
- J04 Detached 4mm flexible cable
- J06 Detached 6mm flexible cable
- K04 Detached 4mm rigid probe
- K06 Detached 6mm rigid probe
- C04 Coaxial / 4mm probe
- C06 Coaxial / 6mm probe
- B11 11mm segmented rigid probe with centering disc connection (TB10/TN10 mounting only). Segment Lengths ordered as separate Accessories

##### Probe Variant / Materials

- S 316L
- L Monel 400
- P PTFE

##### Mounting

- TN07 3/4" NPT Thread
- TB07 3/4" BSP Thread
- TN10 1" NPT Thread
- TB10 1" BSP Thread
- FXXX<sup>1</sup> Integrated Flange (replace XXX with 3 character Integrated Flange Code)

##### Process O-ring Seal / Process Temperature

- |                  |                   |   |
|------------------|-------------------|---|
| V1 FKM (Viton)   | (-40°C to +80°C)  | (-40°F to +176°F)                               |
| V4 FKM (Viton)   | (-40°C to +150°C) | (-40°F to +302°F)                               |
| B1 NBR           | (-40°C to +80°C)  | (-40°F to +176°F)                               |
| E1 EPDM          | (-40°C to +80°C)  | (-40°F to +176°F)                               |
| E3 EPDM          | (-40°C to +130°C) | (-40°F to +266°F)                               |
| M1 FFKM (Markez) | (-10°C to +80°C)  | (+14°F to +176°F)                               |
| M4 FFKM (Markez) | (-10°C to +150°C) | (+14°F to +302°F)                               |
| M5 FFKM (Markez) | (-10°C to +200°C) | (+14°F to +392°F)                               |
| M6 FFKM (Markez) | (-5°C to +250°C)  | (+23°F to +482°F) (Max Process Pressure 40 bar) |
| S1 Silicone      | (-40°C to +80°C)  | (-40°F to +176°F)                               |



### Process Pressure

- 1 6 bar (87 psig)
- 3 20 bar (290 psig)
- 4 40 bar (580 psig)
- 5 100 bar (1450 psig)

### Approval Standard

- XX Not Required
- 1D IECEx Ex ia/db [ia Ga] IIC T6...T2 Ga/Gb
- 2D IECEx Ex ia tb [ia Da] IIIC T85°C...T250°C Da Db
- 1U FM XP Cl I, Div 1, Gp B-D with IS Probe Cl I, Div I, Gp A-D, T6...T2B, Ta = T\* to 60°C; Cl. I Zone 0/1 AEx ia/db [ia Ga] IIC T6...T2 Ga/Gb
- 2U FM DIP-IS, Cl II, III, Div 1, Grp E, F and G, T6...T2B, Ta = T\* to +60°C; Zone 20/21 AEx ia IIIC T85°C...T250°C Da; AEx tb IIIC T85°C Db, Ta = T\* to +60°C
- GP FM/CSA General Purpose
- 1C CSA XP Cl I, Div 1, Gp B-D with IS Probe Cl I, Div I, Gp A-D, T6...T2B<sup>3</sup>
- 2C CSA Ex ia/db IIC T6...T2 Ga/Gb<sup>3</sup>
- 3C CSA DIP-IS, Class II, III, Division 1, Groups E, F and G, T6...T2B<sup>3</sup>
- 4C CSA Ex ia IIIC T85°C...T250°C Da; Ex tb IIIC T85°C Db<sup>3</sup>
- 1A ATEX II 1/2 G Ex ia/db IIC T6...T2 Ga/Gb
- 2A ATEX II 1/2 D Ex ia IIIC T85°C...T250°C Da / Ex tb IIIC T85°C Db
- 3A ATEX II 3 G Ex ic/dc IIC T6... T2 Gc Tamb -40°C to 60°C
- 6A ATEX II 3 D Ex ia IIIC T85°C...T255°C Dc Tamb -40°C to 60°C, Ex tb IIIC T85°C Dc<sup>5</sup>
- 6A ATEX II 3 D Ex tc IIIC T85°C ... T250°C Dc Tamb -40°C to 60°C

### Probe Length

Specify in cm

**CGR2 H 1 3 B04 S TN10 B1 1 XX 200**

### Probe Type 'B11' Segmented Probe Pieces

CGR-B11SEG-S-XX-L= (L = Specify length of piece in cm. Material 316L. No centering disc)

CGR-B11SEG-S-CD-L= (L = Specify length of piece in cm. Material 316L. With centering disc)

### Probe / Mounting Combination Table

Probe Code	Variant / Materials	Mounting	Flange Sizes <sup>2</sup>		Max. Length
			Min. Size	Max size	
A04 / J04	S, L, P	TN07, TB07, FXXX	1", DN25, 25mm	4", DN100, 100mm	3800cm
A06 / J06	S, L, P	TN10, TB10	2", DN50, 50mm	4", DN100, 100mm	3800cm
B04 / K04	S, L	TN07, TB07, FXXX	1", DN25, 25mm	4", DN100, 100mm	400cm
B06 / K06	S, L	TN10, TB10	2", DN50, 50mm	4", DN100, 100mm	400cm
B11	S, L	TN10, TB10	2", DN50, 50mm	4", DN100, 100mm	600cm

<sup>1</sup>See Integrated selection in Flange Table.

<sup>2</sup>HAWK Supplied Flanges. End user can use any appropriate flange with suitable bore hole.

<sup>3</sup>NPT conduit / cable thread only

<sup>4</sup>Hazardous Approval 'XX, 6A' only

<sup>5</sup>Housing Option A, B only

<sup>6</sup>Model type 'CGR2' only

<sup>7</sup>Model type 'CGR4' only

<sup>8</sup>Housing option 'A, B, C, D' only. Approval Standard 'XX' only

\* Refer to Safety Instructions





### Centurion Guided Radar System

#### 1.5" Threaded Units (mounting option TN15, TB15, Flanged)

##### Model

CGR2 Centurion Guided Radar 2 Wire

CGR4 4 wire Centurion Guided Radar

##### Communication

H 4-20mA with HART 7<sup>6</sup>

I 4-20mA with HART 7 and Interface Level<sup>6</sup>

L 4-20mA with HART 7 and SIL2<sup>6</sup>

W Modbus with Interface Level<sup>7</sup>

E Modbus over PoE (Powered Ethernet). HawkEye365 compatible<sup>7,8</sup>

##### Housing

- |  |  |
|--|--|
| 1 Dual Chamber Aluminium, epoxy painted with viewing window            | A Single Chamber Aluminium, powder coated with viewing window <sup>4</sup> |
| 2 Dual Chamber 316L Stainless Steel, with viewing window               | B Single Chamber Aluminium, powder coated, no viewing window <sup>4</sup>  |
| C Single Chamber 316L Stainless Steel with viewing window <sup>4</sup> | D Single Chamber 316L Stainless Steel with no viewing window <sup>4</sup>  |

##### Conduit / Cable Entry

- 1 1/2" NPT                      3 M20 x 1.5

##### Probe Type

- A08 8mm flexible cable  
B08 8mm rigid probe  
J08 Detached 8mm flexible cable  
K08 Detached 8mm rigid probe  
C08 Coaxial / 8mm probe

##### Probe Variant / Materials

- S 316L  
L Monel 400  
P PTFE

##### Mounting

- TN15 1.5" NPT  
TB15 1.5" BSP  
FXXX<sup>1</sup> Flanged (no threaded connection) (replace XXX with 3 character Integrated Flange Code)

##### Process O-ring Seal / Process Temperature

- V1 FKM (Viton) (-40°C to +80°C) (-40°F to +176°F)  
V3 FKM (Viton) (-40°C to +130°C) (-40°F to +266°F)  
B1 NBR (-40°C to +80°C) (-40°F to +176°F)  
E1 EPDM (-40°C to +80°C) (-40°F to +176°F)  
E3 EPDM (-40°C to +130°C) (-40°F to +266°F) (Max. Process Pressure 6 bar / 87 psig)  
S1 Silicone (-40°C to +80°C) (-40°F to +176°F)  
S3 Silicone (-40°C to +130°C) (-40°F to +266°F) (Max. Process Pressure 6 bar / 87 psig)

##### Process Pressure

- 1 6 bar (87 psig)  
3 20 bar (290 psig)  
4 40 bar (580 psig)



### Approval Standard

- XX Not Required
- 1D IECEx Ex ia/db [ia Ga] IIC T6...T2 Ga/Gb
- 2D IECEx Ex ia/tb [ia Da] IIIC T85°C...T250°C Da Db
- 1U FM XP CI I, Div 1, Gp B-D with IS Probe CI I, Div I, Gp A-D, T6...T2B, Ta = T\* to 60°C; CI. I Zone 0/1 AEx ia/db [ia Ga] IIC T6...T2 Ga/Gb
- 2U FM (USA) DIP-IS, CI II, III, Div 1, Grp E, F and G, T6...T2B, Ta = T\* to +60°C; Zone 20/21 AEx ia IIIC T85°C...T250°C Da; AEx tb IIIC T85°C Db, Ta = T\* to +60°C
- GP FM/CSA General Purpose
- 1C CSA XP CI I, Div 1, Gp B-D with IS Probe CI I, Div I, Gp A-D, T6...T2B<sup>3</sup>
- 2C CSA Ex ia/db IIC T6...T2 Ga/Gb3
- 3C CSA DIP-IS, Class II, III, Division 1, Groups E, F and G, T6...T2B<sup>3</sup>
- 4C CSA Ex ia IIIC T85°C...T250°C Da; Ex tb IIIC T85°C Db<sup>3</sup>
- 1A ATEX II 1/2 G Ex ia/db IIC T6...T2 Ga/Gb
- 2A ATEX II 1/2 D Ex ia IIIC T85°C...T250°C Da / Ex tb IIIC T85°C Db
- 3A ATEX II 3 G Ex ic/dc IIC T6... T2 Gc Tamb -40°C to 60°C
- 6A ATEX II 3 D Ex ia IIIC T85°C...T255°C Dc Tamb -40°C to 60°C, Ex tb IIIC T85°C Dc<sup>5</sup>
- 6A ATEX II 3 D Ex tc IIIC T85°C ... T250°C Dc Tamb -40°C to 60°C

### Probe Length

Specify in cm

**CGR2 H 1 3 B08 S TN15 B1 1 XX 200**

### Probe / Mounting Combination Table

Probe Code	Variant / Materials	Mounting	Flange Sizes <sup>2</sup>		Max. Length
			Min. Size	Max size	
A08 / J08	S, L, P	TN15, TB15, FXXX	2", DN50, 50mm	4", DN100, 100mm	3800cm
B08 / K08	S, L	TN15, TB15, FXXX	2", DN50, 50mm	4", DN100, 100mm	400cm

<sup>1</sup>See Integrated selection in Flange Table.

<sup>2</sup>HAWK Supplied Flanges. End user can use any appropriate flange with suitable bore hole.

<sup>3</sup>NPT conduit / cable thread only

<sup>4</sup>Hazardous Approval 'XX, 6A' only

<sup>5</sup>Housing Option A, B only

<sup>6</sup>Model type 'CGR2' only

<sup>7</sup>Model type 'CGR4' only

<sup>8</sup>Housing option 'A, B, C, D' only. Approval Standard 'XX' only

\* Refer to Safety Instructions



## Mounting Flanges

### Threaded Flanges

**Model**

FLA - **Flange Size**

- 1 1" or DN25 or 25mm
- H 1 1/2" or DN40 or 40mm
- 2 2" or DN50 or 50mm
- K 2 1/2" or DN65 or 65mm
- 3 3" or DN80 or 80mm
- L 3 1/2" (ANSI ONLY)
- 4 4" or DN100 or 100mm

**Flange Type**

- A1 ANSI B16.5 150LB FLANGE
- A3 ANSI B16.5 300LB FLANGE
- A6 ANSI B16.5 600LB FLANGE
- A9 ANSI B16.5 900LB FLANGE
- AA ANSI B16.5 1500LB FLANGE
- AB ANSI B16.5 2500LB FLANGE
- D6 DIN2527 PN6 FLANGE
- D0 DIN2527 PN10 FLANGE
- D1 DIN2527 PN16 FLANGE
- D2 DIN2527 PN25 FLANGE
- D4 DIN2527 PN40 FLANGE
- J5 JIS 5K FLANGE
- J0 JIS 10K FLANGE
- J1 JIS 16K FLANGE
- J2 JIS 20K FLANGE
- J4 JIS 40K FLANGE
- S1 AS 2129 Table D
- S2 AS 2129 Table E
- S3 AS 2129 Table F
- S4 AS 2129 Table H

**Material**

SS SS316L

**Thread Type**

- TB07 3/4" BSP THDs
- TB10 1" BSP THDs
- TB15 1 1/2" BSP THDs
- TN07 3/4" NPT THDs
- TN10 1" NPT THDs
- TN15 1 1/2" NPT THDs

**FLA - 2 A1 - SS - TB15**

### Integrated Flanges

**Model**

F **Flange Size**

- 1 1" or DN25 or 25mm
- H 1 1/2" or DN40 or 40mm
- 2 2" or DN50 or 50mm
- K 2 1/2" or DN65 or 65mm
- 3 3" or DN80 or 80mm
- L 3 1/2" (ANSI ONLY)
- 4 4" or DN100 or 100mm

**Flange Type**

- A1 ANSI B16.5 150LB FLANGE
- A3 ANSI B16.5 300LB FLANGE
- A6 ANSI B16.5 600LB FLANGE
- A9 ANSI B16.5 900LB FLANGE
- AA ANSI B16.5 1500LB FLANGE
- AB ANSI B16.5 2500LB FLANGE
- D6 DIN2527 PN6 FLANGE
- D0 DIN2527 PN10 FLANGE
- D1 DIN2527 PN16 FLANGE
- D2 DIN2527 PN25 FLANGE
- D4 DIN2527 PN40 FLANGE
- J5 JIS 5K FLANGE
- J0 JIS 10K FLANGE
- J1 JIS 16K FLANGE
- J2 JIS 20K FLANGE
- J4 JIS 40K FLANGE
- S1 AS 2129 Table D
- S2 AS 2129 Table E
- S3 AS 2129 Table F
- S4 AS 2129 Table H

**F 2 D4**

### Tank Fastening Kits For Probes

**Flexible Probes (316L)**

CGR-A0X-WL-SS

**Rigid Probes (316L)**

CGR-B0X-PL-SS

### Centering Discs

*Centering disc will add 50mm (2") to the end of the probe*

CGR-CDAAXX-11-PK

Centering Disc Kit For 11mm Probe (PEEK)

CGR-CDAAXX-11-PT

Centering Disc Kit For 11mm Probe (PTFE)

CGR-CDAAXX-11-S6

Centering Disc Kit For 11mm Probe (316L)

CGR-CDAAXX-11-MN

Centering Disc Kit For 11mm Probe (Monel 400)

# Specifications

## Centurion Guided Radar



Specifications dependent on model selection.

## Electronics

### Power

- 2 wire loop powered
- 24VDC (14 to 28VDC)
- Ethernet Powered (48VDC)

### Power Consumption

- <500mW @ 24VDC

### Analog Output

- 14V @ 0 Ohm
- 19V @ 250 Ohms
- 24V @ 500 Ohms
- Current park at 4mA, 8mA, 12mA

### Communications

- HART (Revision 7)
- GoshawkII via HART, Modbus, Ethernet
- Ethernet
- HawkEye365

### Maximum Range

- Flexible cable probe: 38m (124ft)
- Rigid probe: 4m (13ft 1in)
- Segmented Rigid probe (B11 type): 6m (13ft 1in)

### Minimum Range (Blanking)

- <=150mm (6.0")

### Dielectric Range

- ≥ 1.5 (Interface mode requires low to high dielectric layers)

### Frequency

- 2.2 GHz

### Resolution

- Analog: 1uA
- Display: 1.0mm

### Accuracy

- +/- 3mm

### Measurements Per Second

- 3

### Response Time

- <1 second (application dependant)

### Sum of Non Linearity, Non repeatability, Hysteresis

- Analog +/- 0.02%

### Repeatability

- +/- 3mm

### Memory

- Non-Volatile (No backup battery required)
- >10 years data retention

### Operating Temperature (Electronics)

- -40°C to +80°C (-40°F to +176°F)

### Display

- 4 line graphic display (128 x 64 pixels)

### Language

- English

### Configuration

- 4 button (up down, Cal, Run), GoshawkII via HART. HART 7 DD/DTM

### Approvals

- **Certificate No. IECEx TSA 14.0037X**  
**IECEx Zone 0/1, Zone 1**  
Ex ia/d [ia Ga] IIC T6...T2 Ga/Gb Tamb = -40°C to +60°C  
**IECEx Zone 20/21**  
Ex ia tb [ia Da] IIIC T85°C...T255°C Da Db Tamb = -40°C to +60°C
- **Certificate No. FM18US0194X**  
**FM Class I Div 1 & Class I, Zone 0/1**  
XP Cl. I Div 1 Gp B-D with IS Probe Cl I, Div I, Gp A-D, T6...T2B Ta = -\*\*°C to +60°C  
Cl I, Zone 0/1 AEx ia/db IIC T6...T2 Ga/Gb Ta = -\*\*°C to +60°C  
**FM Class II,III Div 1 & Zone 20/21**  
DIP-IS Class II, III, Division 1, Groups E,F and G T6...T2B Ta = -\*\*°C to +60°C  
Zone 20/21 AEx ia IIIC T85°C...T255°C Da; AEx tb IIIC T85°C Db, Ta = -\*\*°C to +60°C
- **Certificate No. FM18CA0091X**  
**CSA Class I Div 1**  
XP-AIS Cl. I Div 1 Grp B-D with IS Probe Cl I, Div I, GP A-D, T6...T2B  
Ta = -\*\*°C to +60°C  
**CSA Class I, Zone 0/1**  
Ex ia/db IIC T6...T2 Ga/Gb Ta = -\*\*°C to +60°C  
**CSA Class II,III Div 1**  
DIP-IS Cl. II,III Div 1 Groups E, F and G T6...T2B Ta = -\*\*°C to +60°C  
**CSA Zone 20/21**  
Ex ia IIIC T85°C...T250°C Da; Ex tb T85°C, Db Ta = -\*\*°C to +60°C
- **Certificate No. FM18ATEX0046X**  
ATEX Ex II 1/2 G Ex ia/db IIC T6...T2 Ga/Gb Ta = -\*\*°C to +60°C  
ATEX Ex II 1/2 D Ex ia IIIC T85°C...T250°C Da; Ex tb IIIC T85°C Db  
Ta = -\*\*°C to +60°C
- **Certificate No. FM18NUS0014**  
**FM General Purpose**  
FM Class 3810: 2018, ANSI/ISA 61010-1: 2012, ANSI/NEMA 250:2003,  
ANSI/IEC 60529:2004
- **Certificate No. FM18NCA0005**  
**CSA General Purpose**  
CSA-C22.2 No. 94:2011, CSA-C22.2 No. 60529: 2010, CAN/  
CSA-C22.2 No. 61010-1:2012
- **Self Declaration**  
ATEX II 3 D Ex ia IIIC T85°C...T255°C Dc Tamb -40°C to 60°C, Ex tb  
IIIC T85°C Dc5  
ATEX II 3 G Ex ic/dc IIC T6... T2 Gc Tamb -40°C to 60°C  
ATEX II 3 D Ex tc IIIC T85°C ... T250°C Dc Tamb -40°C to 60°C Ex tb  
IIIC T85°C Dc

\*\*Refer to Safety Instructions

# Specifications

## Centurion Guided Radar



Specifications dependent on model selection.

### Electromagnetic Compatibility



CAN ICES-3(A)/NMB-3(A)

This device complies with Part 15, Subpart B Class A of the FCC Rules. Operation is subject to the following two conditions: (1) This device may not cause harmful interference, and (2) this device must accept any interference received, including interference that may cause undesired operation.

*Note: This equipment has been tested and found to comply with the limits for a Class A digital device, pursuant to part 15 of the FCC rules. These limits are designed to provide reasonable protection against harmful interference when the equipment is operated in a commercial environment. This equipment generates, uses and can radiate radio frequency energy and, if not installed and used in accordance with the instruction manual, may cause harmful interference to radio communications. Operation of this equipment in a residential area is likely to cause harmful interference in which case the user will be required to correct the interference at his own expense.*

### SIL Rating

- Certificate No. 968/FSP 1375.01/18
- SIL2                      • SIL3 (multi channel)

### Enclosure

#### Type

- Dual Chamber with viewing window
- Single Chamber with or without viewing window

#### Material

- Die-cast Copper-Free Aluminium, Epoxy Painted
- 316L Stainless

### Conduit / Cable Entry

- 1/2" NPT                      • M20 x 1.5

### IP Rating

- NEMA 4X
- IP66

### Probe

#### Probe Size / Material

- 4mm SS316L / Monel 400 rod
- 4mm DIN3055 (7x7 strand) SS316L flexible cable / PTFE coated
- 6mm SS316L / Monel 400 rod
- 6mm DIN3055 (7x7 strand) SS316L flexible cable / PTFE coated
- 8mm SS316L / Monel 400 rod
- 8mm DIN3055 (7x7 strand) SS316L flexible cable / PTFE coated
- 11mm SS316L / Monel 400 rod

### Wetted Materials<sup>2</sup>

- TN07 / TB07 / TN10 / TB10 / Integrated Flange<sup>1</sup> SS316L / Monel, PEEK
- TN15 / TB15 / Integrated Flange<sup>1</sup> - SS316L / Monel, PTFE, GF25

<sup>1</sup> See Probe / Mounting Combination Table for flange types

### Probe O-Ring Seals / Process Temperature\*

- FKM (Viton)                      -40°C to +150°C    (-40°F to +302°F)
- EPDM                              -40°C to +130°C    (-40°F to +266°F)
- FFKM (Markez)                -10°C to +200°C    (+14°F to +392°F)
- FFKM (Markez)                -5°C to +250°C    (+23°F to +482°F)
- Silicone                         -40°C to +80°C    (-40°F to +176°F)
- Silicone                         -40°C to +130°C    (-40°F to +266°F)
- NBR                                -40°C to +80°C    (-40°F to +176°F)

### Process Connections

- 3/4" NPT                      • 1" NPT                      • 1.5" NPT
- 3/4" BSP                      • 1" BSP                      • 1.5" BSP
- Threaded Flange
- Integrated Flange

### Process Pressure

- -1 to 100 BAR

### Tensile Load (flexible cable probes)

- Probe Type: A04 / J04                      0.5 ton
- Probe Type: A06 / J06                      1.0 ton
- Probe Type: A08 / J08                      4.0 ton

### Lateral Load (Rigid Probes)

- Probe Type: B04 / K04                      1 Nm
- Probe Type: B06 / K06                      3 Nm
- Probe Type: B08 / K08                      8 Nm
- Probe Type: B11                              11 Nm

### Probe Length                      Max                      Min

- Probe Type: A04 / J04                      3800cm    100cm
- Probe Type: A06 / J06                      3800cm    100cm
- Probe Type: A08 / J08                      3800cm    100cm
- Probe Type: B04 / K04                      400cm    20cm
- Probe Type: B06 / K06                      400cm    20cm
- Probe Type: B08 / K08                      400cm    20cm
- Probe Type: B11                              600cm    20cm

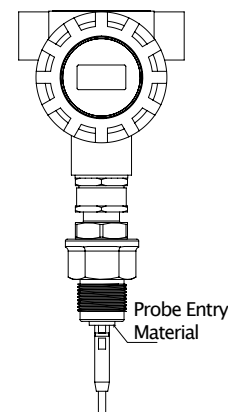

<sup>2</sup> PEEK or PTFE/GF25 probe entry



## Ordering Instructions

---

### Threaded unit type

Assemble part number taking note of the valid combinations and exclusions for the full system. The unit is ordered as a single line item. For example:

CGR2H13B08STB15B11XX200

### Flanged type - Threaded flange

Assemble part number taking note of the valid combinations and exclusions for the full system. The unit and the threaded flange are ordered as separate line items.

For example:

CGR2H13B08STN15B11XX200

FLA-FA4-SS-TN15

or

CGR2H13B08STN07B11XX200

FLA-FA1-SS-TN07

### Flanged type - Integrated flange

Assemble part number taking note of the valid combinations and exclusions for the full system. In the Mounting part code enter 4 character Integrated flange code from the table. All Integrated flanges have F as the first character. For example.

CGR2H13B08SF4A1B11XX200



# Level and Interface Measurement of Liquids and Solids

## Centurion Guided Radar

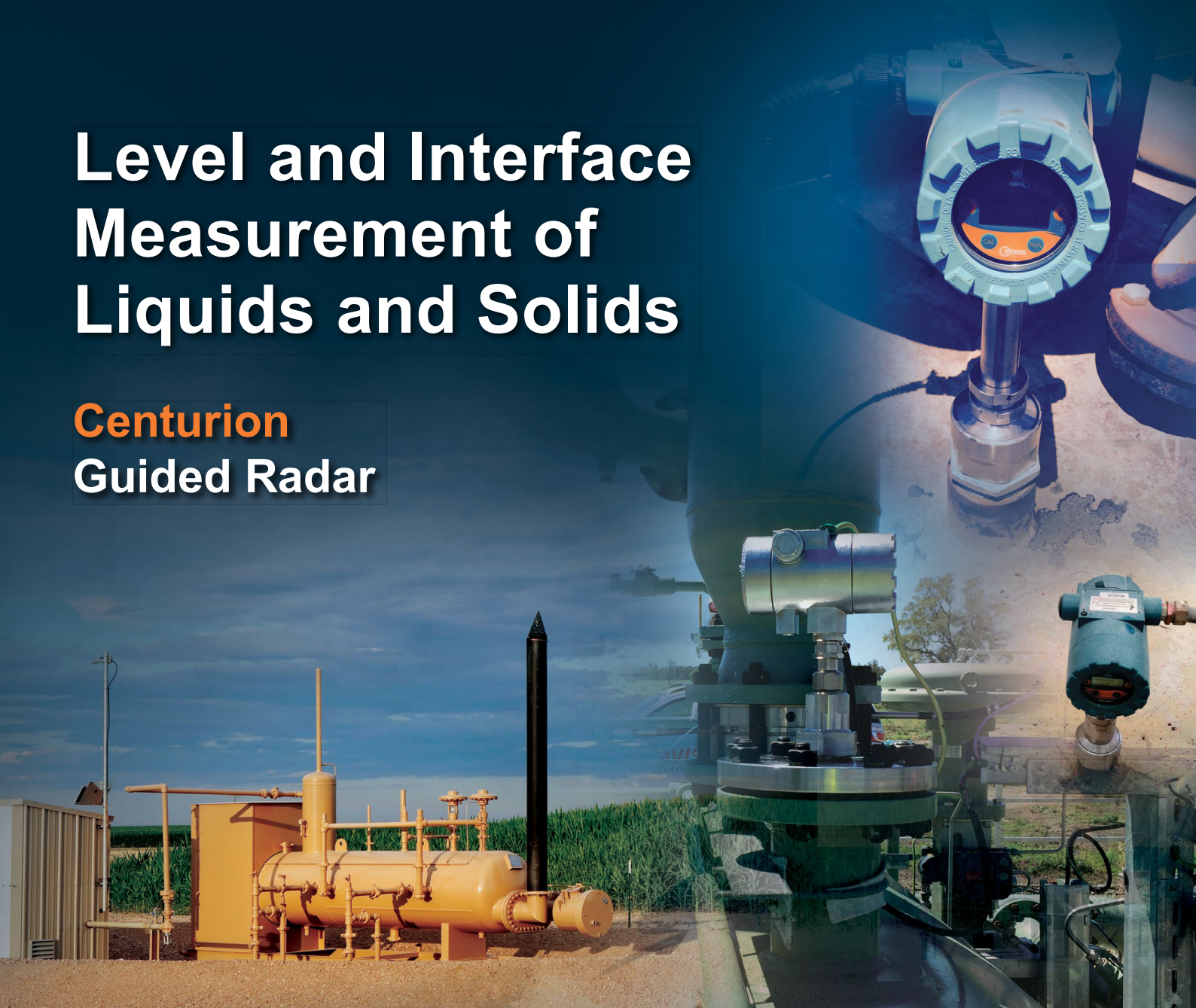

Centurion Guided Radar (CGR) is HAWK's advanced radar technology for measuring liquids & liquid interface (low to high dielectric layers).

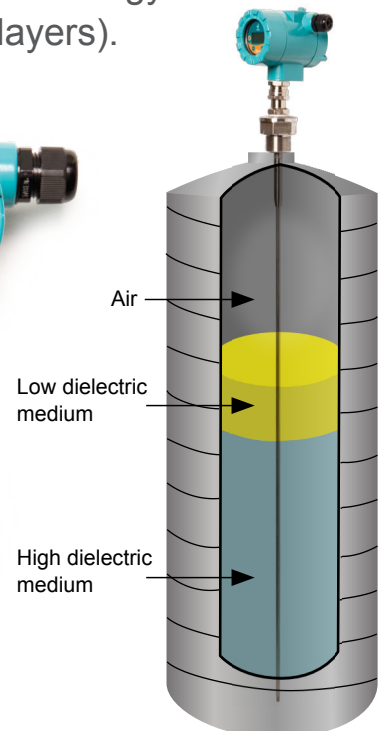
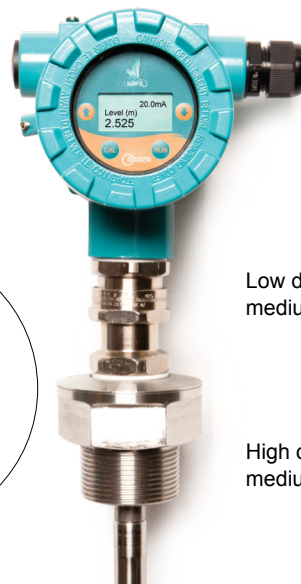





## HAWK, Since 1988

Hawk Measurement Systems Pty Ltd (HAWK) was established in 1988. It's founding members saw the universal requirement of various industries requiring improved process control and efficiency in their operations.

## We Can Help

HAWK understands the difficulties customers face when seeking accurate level measurement. Every application is different, involving a multitude of environmental factors. This is where HAWK excels. Our aim is to ensure that customers feel comfortable with our technology, and are provided with long term and reliable solutions. We believe that a combination of application and product expertise, as well as forward thinking and proactive support policies are the foundation of successful customer-supplier relationships.

## Progressive Technical Support

HAWK believes that the future of the Level Measurement Industry revolves around the quality of pre and post sales - support. Our aim is for all sales & support staff to be product experts, and more importantly application experts making our customers applications as efficient and consistent as possible.

## Knowledge Sharing

HAWK believes that knowledge sharing is key to creating long term relationships. Empowering our customers and our worldwide distribution network, whilst being available at all times to lend a helping hand, is the perfect recipe for long term solutions and relationships. HAWK openly extends an invitation to share our 25 years of level measurement experience, and ensure that your day to day processes are efficient, understood, and always working.

### Hawk Measurement Systems (Head Office)

15 - 17 Maurice Court, Nunawading VIC 3131, AUSTRALIA  
Phone: +61 3 9873 4750  
Fax: +61 3 9873 4538  
info@hawk.com.au

### Hawk Measurement

5010 Gateway Drive, Medina, OH 44256, USA  
Phone: +1 888 HAWKLEVEL (1-888-429-5538)  
Phone: +1 978 304 3000 / +1 877-356-5463  
Fax: +1 978 304 1462 / +1 330-331-7172  
info@hawkmeasurement.com

For more information and global representatives: [www.hawkmeasurement.com](http://www.hawkmeasurement.com)

Technical data subject to change without notice.

All company or product names are registered trademarks or trademarks of their respective owners.

DOC-CGR-DAT Rev.1.02 10/21